

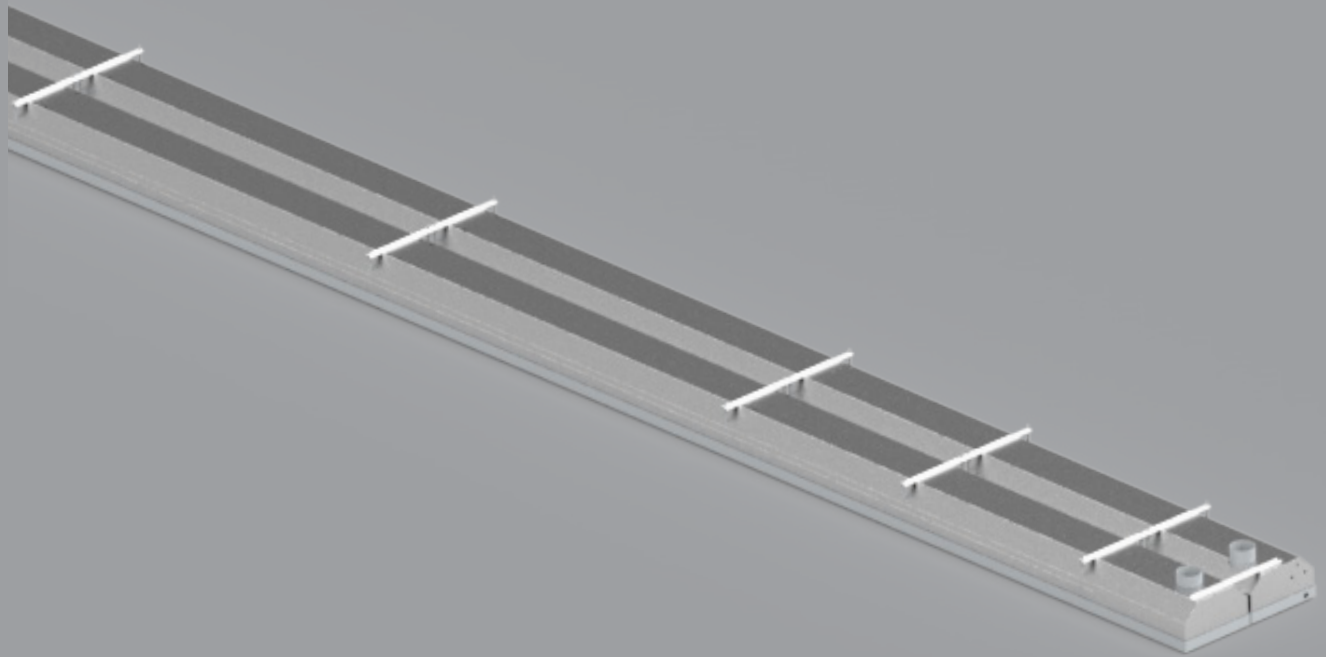

# USER'S MANUAL

---

## PROPANE OR NATURAL GAS-FIRED ZENIT-TYPE TUBE RADIANT HEATER



Appliance types:

ZENIT 80<sup>+</sup> 12...42

Linear - and "U"- form types.

009\_007\_011\_191011\_V002\_EN

# Contents

<b>1. SAFETY INFORMATION</b> .....	3
<b>2. GENERAL INSTRUCTION</b> .....	4
Installer's responsibilities .....	4
Data board .....	4
Corrosive materials .....	5
Standards and laws .....	5
Safety signs .....	5
Safe usage .....	5
<b>3. TRANSPORTATION, UNPACKING, HANDLING</b> .....	6
<b>4. OPERATION PRINCIPLE</b> .....	6
<b>5. INSTALLATION</b> .....	7
Components of „I” -form tube radiant heater, assembly distances .....	7
Components of „U” -form tube radiant heater, assembly distances .....	7
Appliance installation .....	8
Electrical connection .....	8
Regulatory options .....	9
Electrical connection scheme of SIT 579 DBC type automatic burner control .....	9
Optional accessories .....	9
Electrical connection .....	10
Protective distances .....	10
Combustion-air supply .....	12
<b>6. EXHAUST SYSTEM POSSIBILITIES</b> .....	12
Exhaust out taking +combustion air intaking .....	14
<b>7. APPLIANCE OPERATION</b> .....	16
<b>8. APPLIANCE SPECIFICATION</b> .....	16
Start, restart .....	16
Operation of automatic burner control ( SIT 579 DBC typ) .....	16
<b>9. MAINTANCE</b> .....	17
Check at the beginning of season .....	17
Maintenances .....	17
Maintenance supervisions by a qualified service department .....	18
Gas change .....	18
<b>10. TROUBLESHOOTING</b> .....	18
<b>11. ENCLOSURE</b> .....	19
Enclosure 1.: Variety-list of ZENIT 80+ -type tube radiant heaters .....	19
Enclosure 2.: Heating and consumption values of ZENIT 80+ -type tube radiant heaters .....	20
ECO-Design Declaration of Conformity .....	21

# 1. SAFETY INFORMATION



**Read and understand this manual thoroughly before installing starting or servicing this equipment. The improper installation or using can cause serious damages! Keep this manual in a safe place in order to obtain information in case of incidental problems!**

## GENERAL SAFETY NOTICES

**Disregard of instructions and notices of this Manual can cause serious bodily injuries or damages as follows: burning, explosion, suffocation, carbon monoxide poisoning, electric shock and in extreme case death!**



**This appliance can only be used and serviced by such persons who understood and follow the instructions of this Manual**

**If you need help or information concerning the appliances – for example installation guide or labels etc. – in that case contact with the manufacturer!**

**This appliance must not be used by children and mentally or sensitively deficient persons! Take care that the children do not handle it and do not play with devices!**



**ATTENTION! Fire, burning, inhalation and explosion hazard! Keep all flammable objects as follows building materials, papers, or carton unites away from heater according to the instructions! Never use this appliance in such rooms where there are flammable volatile materials or the following materials, which can get into the device: petrol, solvent, thinner, fine grained dusty or unknown chemical materials!**



**ATTENTION! This appliance can not be used in domestic circumstances or mobile home!**



**ATTENTION! For your safety, if you smell gas do the followings:**

- **Open windows.**
- **Do not try to light any appliance.**
- **Do not use electrical switches.**
- **Do not use any telephone in your building.**
- **Leave the building.**
- **Immediately call your local gas supplier after leaving the building. Follow the gas supplier's instructions.**
- **If you cannot reach your gas supplier, call the Fire Department.**

The ZENIT 80+ -type tube radiant heater appliances have been developed and certified in compliance with EN 416 standard and qualified for heating of industrial rooms! The function of these heater appliances to ensure heating of appointed workplace temporarily or continuously! In case of proper using the appliance guarantees safety and energy-saving operation! The combustion products issued during combustion process leave through the flue system into the open air. In case of further possible questions regarding the applicability please turn to the local Fire Protection Office!

Other standards can give you directions in terms of proper using of natural and propan gas as follows: leading/piping, storing etc.! Concerning the detailed content of these standards the local Bureau of Standards can help.

**Carbon- monoxide poisoning:** The initial symptoms of carbon-monoxide poisoning are similar to influenza namely headache, dizziness and/or nausea! If these symptoms are observed in that case the appliance probably does not work satisfactorily! First of all go fresh air, ventilate the rooms and have the appliance investigated!

**Propan-gas:**The propan-gasis odorless! Mercaptan-derivative as scented component is mixed into the gas to be able to observe the possible escape! In spite of the typical smell is not felt the propan gas can be present in the environmental air in case of escaping!

## 2. GENERAL INSTRUCTION

- Make sure that read and understood all the warnings, correct keeping of which can guarantee the safety and faultless operation !
- During the installation be always circumspect! Follow the valid instructions and recommendations!
- The appliance can be operated by specified voltage and frequency marked on its data board! The electrical connections and groundings are prepared as per MSZ EN 60335 standard!
- Electrical grounding specification: present appliance is equipped with three points grounding connection in the interests of your protection!
- It needed to ensure the sufficient quantity of combustion air if the appliance is installed without outside air supply!
- Keep away the device from the following strong effects: wind, high pressure water jet, rain or dropping water!
- The appliance must not be used in the open air!
- The application of device is STRICTLY PROHIBITED in such rooms, which are used for sleep or continuous stay!
- Keep away the flammable materials from the appliance and its near environment as follows: fuels, thinner or other flammable fluids and vapours!
- In the interests of avoiding of dust explosion do not used the device in such rooms where the degree of dust concentration is high if the device is installed without outside air supply!
- Before starting of appliance in every case check it in order to detect the possible damages! Never use damaged equipment!
- In case of Propan-gas operation never install the device in basement or from that lower being rooms! The propan-gas is heavier specific gravity than the air for this reason in case of possible escaping it will spread towards the lower located rooms !
- Only use that kind of flexible gas pipe and pressure regulator, which is offered for the appliance by the manufacturer!
- Before every starting of heater appliance check the condition of connecting gas hose and if it is particularly worn or damaged in that case exchange it for a new one specified by manufacturer!
- Preserve the equipment in genuine condition, do not leave it to grow old!
- Do not use seriously aged equipment any longer!
- Fix the appliance on such stable surface, which during operation despite warming of appliance preserves its stability !
- If the appliance is put out of use in every case it must be cut off the current and gas!
- Never block the air supply and exhaust pipes!
- Keep away the children and animals from the equipment!
- Never service/mend such devices, which are hot and during operation or electrical charged!
- Never mount such air duct unit on front or back side of device, which is not approved by manufacturer!
- Use exclusively genuine-approved by manufacturer-spare parts, do not install similar quality spare parts for substitution! These kind of substitute parts can cause serious damages concerning the operation of appliance!
- Fix the appliance on such stable surface, which during operation despite warming of appliance preserves its stability !
- If the appliance is put out of use in every case it must be cut off the current and gas!
- Never block the air supply and exhaust pipes!
- Keep away the children and animals from the equipment!
- Never service/mend such devices, which are hot and during operation or electrical charged!
- Never mount such air duct unit on front or back side of device, which is not approved by manufacturer!
- Use exclusively genuine-approved by manufacturer-spare parts, do not install similar quality spare parts for substitution! These kind of substitute parts can cause serious damages concerning the operation of appliance!

### INSTALLER'S RESPONSIBILITIES

- making up of gas and electrical connection in compliance with the specifications (it is proposed to connect with the local Building Supervisory Authority or Fire-service),
- installation of equipment in accordance with the definitions of this manual,
- installation according to the fire prevention rules,
- supply of the necessary materials/components for installation(which are not belong to appliance),
- planing of air duct systems (ventilation/connections)
- service execution,
- placing the copy of present manual at owner's disposal,
- assuring of sufficient air circulation around the appliance,
- determination and assuring of needed air for burning, ventilation and blowing in according to the specifications.

### DATA BOARD

The appliance is equipped with data board, which is placed on outside of device's door. On this data board there are information concerning the type of device, gas type, electrical connection and flue types.

<b>Manufacturer</b> <b>PAKOLE Trade Kft.</b> <b>8000 Székesfehérvár,</b> <b>Börgöndi út 8-10.</b>	<b>Type</b> <b>ZENIT-32/L</b>		 <b>1008 14</b>  <b>PIN:</b> <b>1008 CP 2745</b>
	<b>Nominal input:</b>	<b>32 kW</b>	
<b>Electrical connection:</b>	<b>AC 230V 50Hz</b>		<b>Jet pressure:</b>
<b>Max.current entry:</b>	<b>0,45 A</b>		
<b>Flue system</b>	<b>B23, C13, C33, C53</b>		<b>Pconnecting min.:</b>
<b>Series number:</b>	<b>20-2904-00001</b>		<b>15 mbar</b>
<b>Gas type:</b>	<b>Naturalgas</b>		<b>Electrical protection:</b>
	<b>Targeted country:</b>	<b>NOx</b>	<b>IP21</b>
	<b>GB</b>	<b>4</b>	<b>Date/place of production</b> <b>2017.10.21.</b>

## CORROSIVE MATERIALS

**ATTENTION! Do not use the appliance in such place where corrosive materials can be in the air! If the appliance has to be applied in this circumstances outside air has to be ensured for combustion air!**

The manufacturer can not assume responsibility for fault of equipment in case the installation is not happened according to the above. This responsibility concerns completely the installer. In order to avoid such eventualities, if it is not certain to fit to the building or activity, ask our colleague for help

Both the owner and the installer have to identify every possible material, which can be present in the building (inflammable materials, corrosive materials, halo hydrocarbons etc.), and with knowledge of these materials must be planned the heater system!

## STANDARDS AND LAWS

Every appliance installation must be satisfied the valid laws and standards. These laws refer to the gas and electrical installation respectively the ventilation (special specifications refer to park houses, airplane hangars etc).

## SAFETY SIGNS

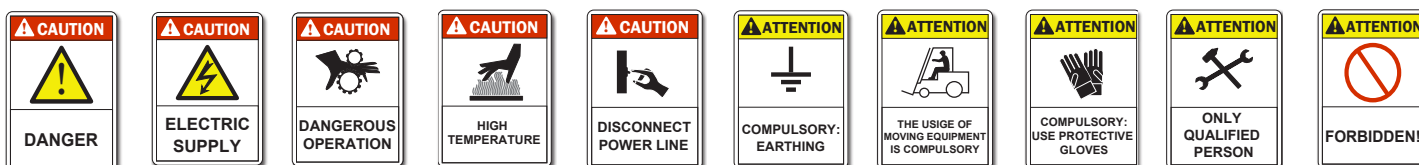

## SAFE USAGE



**Please observe the following rules during installation, first set-up, usage or maintenance:**

- Installation must be carried out always strictly complying with the current standards of the country where the appliance is going to be used and following, of course, the instructions given by the producer.
- The installation and maintenance operations of the unit can be carried out by qualified and trained personnel only.

Qualified service engineers are those having specific technical experience and/or valid license in the field of heating and cooling installation for home and industry. In any case, call the Manufacturer office or the closest dealer ([www.pakole.com](http://www.pakole.com)) and ask for further informations.

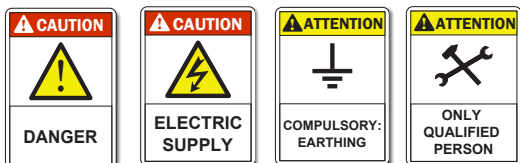

- According to the installation project, install the electric power lines.
- Always make sure that the unit and all its electrical parts have been correctly earthed prior starting up the unit.



- If you have to disassemble the unit, use special protective gloves.
- Beware of sharp edges inside the unit!
- Beware of roof corners of outdoor units!
- Keep suction grids always clear!

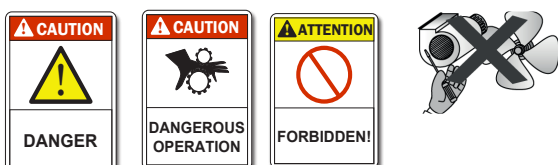

- Before cleaning or maintaining the unit, make sure that all electrical parts have been switched off, the appliance gas supply chain is closed and wait until the appliance cools down. In particular, make sure that the fan is off and cannot be inadvertently started prior to opening inspection panels.
- Fans can reach a speed of 1000 rpm. Do not insert any object nor hands in the electric fan.

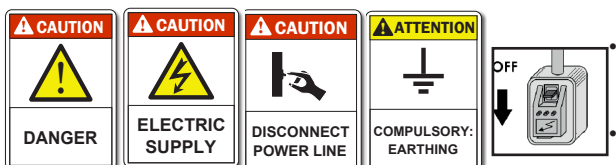

We recommend to install a safety switch which can be easily reached to cut off the current, near the unit. Before any cleaning and servicing operation, cut off the power line to the unit.

Before opening the unit, make sure that all electrical parts have been switched off. In particular, make sure that the fan is off and cannot be inadvertently started prior to opening inspection panels.

### CHECK THE EARTHING !!



- This unit is designed to be used for heating purposes only. Any different use is not allowed as it may be dangerous.
- Should the unit work in a house where disabled people and/or children live, it must be placed safely away from their reach. Always make sure that the access door to the inside control board stay locked.
- An incorrect installation can cause damages to people, animals and property. In case of erroneous installation, the manufacturer cannot be held responsible for such damages.
- **The manufacturer cannot be held responsible for such damages by improper uses, errate uses, etc.**



- Never use the unit to support other equipment.
- Never leave tools, spare parts, etc. inside the unit.
- Make sure that all inspection panels are closed properly.
- Do not expose the unit to inflammable gases.



- In case of breakdown or failure: turn unit off, do not try to repair it on your own, call operator.
- If you are going to leave the heater switched off for a long time, first make sure that in no way this could cause harm to anyone in any way.

### 3. TRANSPORTATION, UNPACKING, HANDLING

- The delivery must be made according to the following:
  - The package must be carefully secured in the loading space.
  - The package must be transferred in a closed space (always keep packing parts away environmental impacts).
- The unit has a special safety packing for transport and delivery which must be kept in good conditions till the unit is positioned on the installation place.
- Make sure that the unit has all its parts, as specified in the order.
- Check if there are any damages and if the unit abbreviation is the same as the one of the ordered model.
- Every unit is factory tested before shipment, therefore, if there are damages, report them immediately to the carrier.

Transporting, unloading and moving is a process which must be made carefully to avoid any kind of damages. Try not to use the unit's components as hand holds. When lifting, bear in mind that the centre of gravity of the unit may be off-centre.

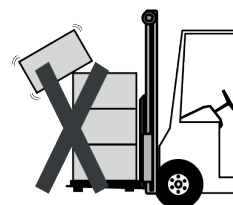

The appliances will be delivered in card board box. The unpacking process of the appliance:

- unload the burner the tubes and the accesories from the card board box.
- **do not remove the protection cap from the burners gas connection or from the gas joining set (optional) until You do not conect it to the pipe line.**
- Check the unit and its accesories for any damages which could be arise during the transportation.
- if there are any damages found, report them immediately to the manufacturer or your closest dealer.

There is an envelope inside the unit containing the Instructions for Installation and Servicing, User's Guide use and Guarantee and services and the warranty documents.

### 4. OPERATION PRINCIPLE

The appliance operates on the basis of radiant heating. The combustion products of burned up gas and air mixture flow through the thin-walled browned straight or „U“-form pipes and warm it up. The aluminium reflektor shields, which have the best reflecting ability radiant the made heat to the heated area.

**Operation principle:** the centrifugal fan of tube radiant heater draws in the combustion-air and pushes out the combustion products - made by burning up of gas and air mixture at the „pusher“ side of fan in the burner head – through the flue system into the open air.

The variety-list of appliances to be found in the **enclosure 1**.

The heating and consumption values to be found in the **enclosure 2**. as per appliance and gas types.

*The supply of combustion air of appliance can be realized in two ways:*

- directly from the heated place
- from open air trough air duct, it can be used in case of such plants, which are working with dangerous materials as follows: painting workshops and workshops, which are using explosive or corrosive materials etc.

## 5. INSTALLATION

### COMPONENTS OF „I”-FORM TUBE RADIANT HEATER, ASSEMBLY DISTANCES

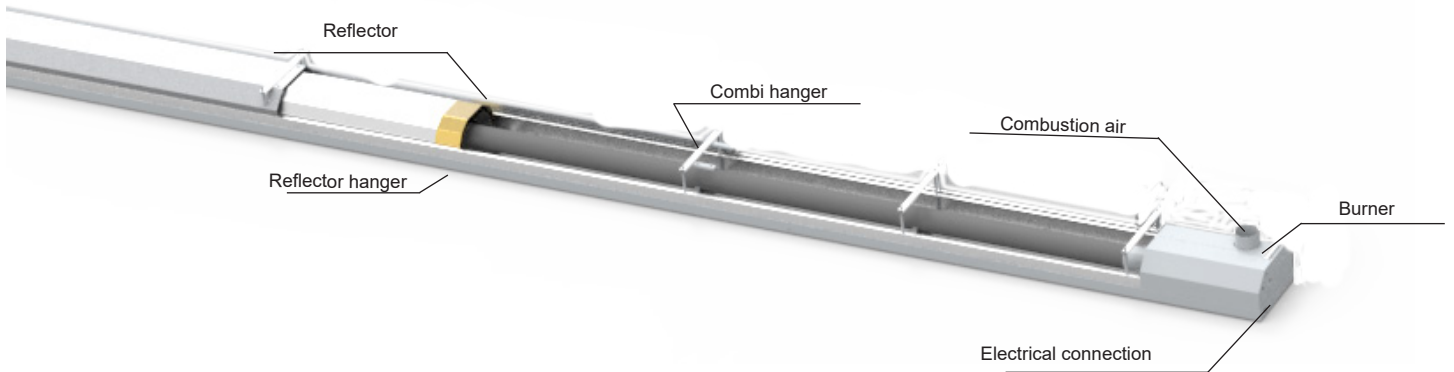

2. picture: "I"-form appliance

### COMPONENTS OF „U”-FORM TUBE RADIANT HEATER, ASSEMBLY DISTANCES

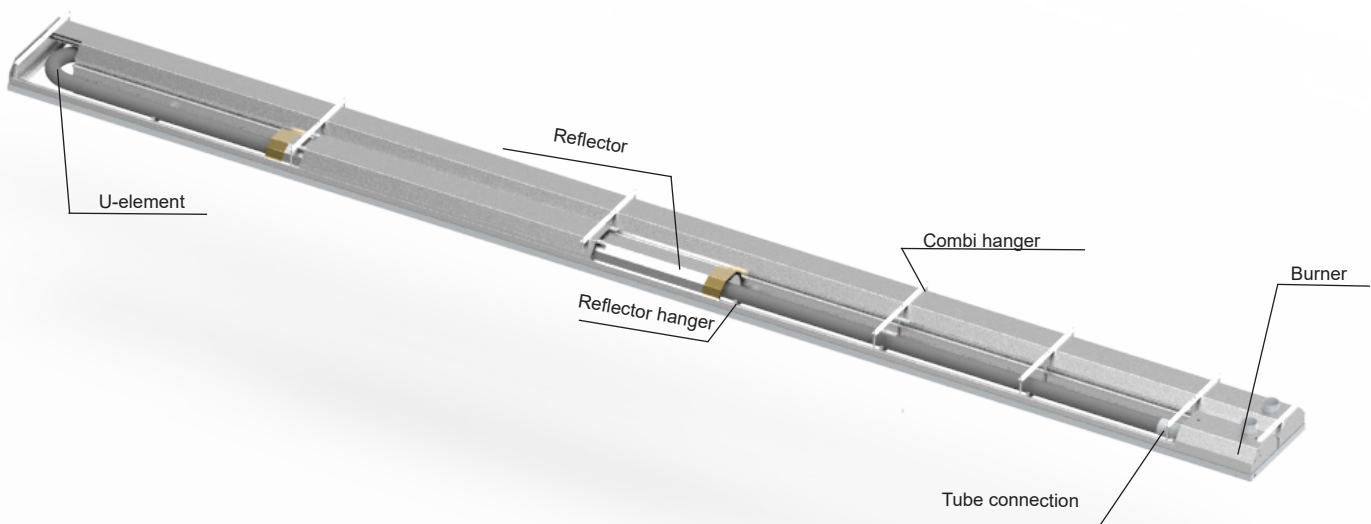

3. picture: "U"- form appliance

## APPLIANCE INSTALLATION

- SOLELY INTERIOR installation is possible.
- The installation must comply with the valid standards.
- For the sake of appropriate efficiency the position and the high of installation has to be carefully defined.
- The appliance has to be placed in that way that its every part be accessible.



**WARNING! Only a qualified person can install the appliances who participated in training which was organised by Pakole Trade Kft in every year. It is forbidden to install the device as an user.**

Attachment of flexible gas pipe has to be directly to the outside threaded gas connection of appliance located on the back side of it.

### Works to be performed during gas connection

- *Gas pipes cleaning*  
The thorough cleaning of gas-supply system is very important before attachment of appliance.
- *Gas leakage checking*  
After installation of appliance make sure about leak-proof mounting of connections. This action must be fulfilled after every dismounting and assembling!

## ELECTRICAL CONNECTION



**ATTENTION! Both the fan and the ignition control needs 230V/50Hz mains voltage. Before connecting the appliance to the gas pipe line, please disconnect it from the power line and close the gas valve front of the burner. The appliance must be connected to a grounded power supply system! If the above instructions are not followed that can lead to death, heavy injuries or property damages!**



**PLEASE CHECK THE EARTHING!**

The combustion–air supply centrifugal fan is fixed to the appliance/burner head, the automatic burner control is located in the burner head in this way the electrical supply has to be installed just into the appliance head.

- ELECTRICAL CONNECTING SPECIFICATIONS:
- The appliance/burner head can be connected to the mains by safety electrical connector (Fig.13) located on the fan side of appliance head.

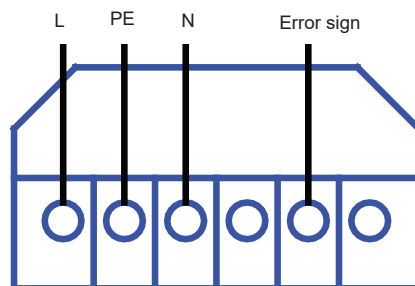

4.picute: Electrical connection

- The appliance must be operated under dry circumstances.
- At electrical installation of appliance the relevant MSZ 2364 standard must be considered.
- The mains connection can be executed by grounded plug or fixed properly installed phase-null wires.
- The appliance is phase-sensitive for this reason the connection always must be according to the Fig.13.
- For the sake of suitable detachability of appliance from the electrical supply, double-pole – phase / null switching off – detaching main-switch must be installed.
- Electrical wiring: 3 x 0,75 MT cable
- Fuse: 2A dissolving fuse
- Before change of dissolving fuse by disconnecting of Hirschmann plug the appliance must be detached from electrical supply.



## MODULATION CONTROL

There are three states according to operation of appliance: Out off operation, operation between performance of 100% and 50% or maximum (100%) performance. Is the control of appliance by the thermostat which can sense the room temperature. The thermostat can control the black tube radiant heater according to needed set up temperature. (The detailed manual of thermostat can be found supplied with thermostat) When the thermostat send a sign than the heater starts with maximum performance (this time is minimum 30 sec) The appliance keeps this performance till the difference is between temperature of room and the setted temperature is 3°C degrees, than the control begin degrease the performance of appliance without any stage continuously to 50% of performance where the control keeps it during this time till the temperature reaches the setted temperature. After these the thermostat sut off the appliance. Type of thermostat can be: only use capable type of control which can handle the modulation control.(e.g.: FP-MOD type by Pakole Trade Kft.)

## REGULATORY OPTIONS

### ELECTRICAL CONNECTION SCHEME OF SIT 579 DBC TYPE AUTOMATIC BURNER CONTROL

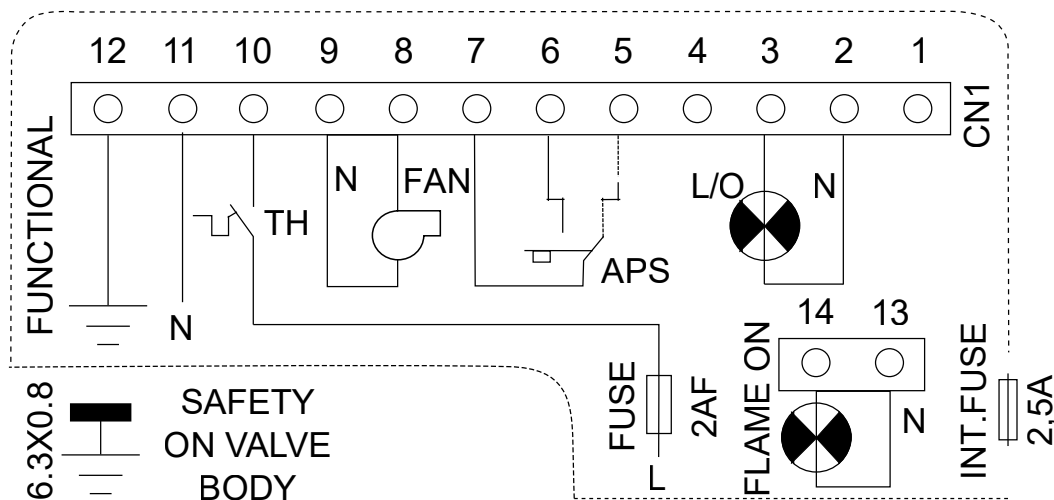

5.picture: SIT 579 DBC Electrical connection

## OPTIONAL ACCESSORIES

### THERMOSTAT

Recommended temperature controllers for the appliance (these can be purchased at the appliance manufacturer)



Temperature sensor

FP-MOD typed thermostat

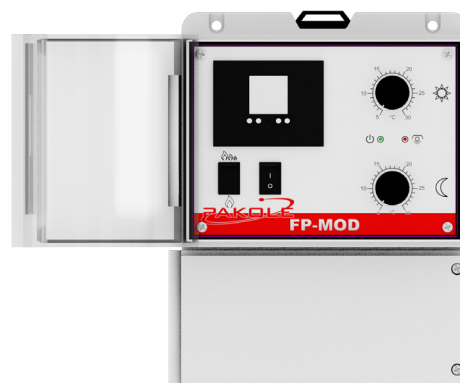

6.picture: Temperature controller



**If the switcher position is „0” does not mean the temperature controller or the ZENIT appliance or a system which is included these, because the appliance is under voltage**

**ELECTRICAL CONNECTION**

**ATTENTION! Both the fan and the ignition control needs 230V/50Hz mains voltage. Before connecting the appliance to the gas pipe line, please disconnect it from the power line and close the gas valve front of the burner. The appliance must be connected to a grounded power supply system! If the above instructions are not followed that can lead to death, heavy injuries or property damages!**



**PLEASE CHECK THE EARTHING!**

**PROTECTIVE DISTANCES**

From flammable materials it is obligatory to keep **SAFETY OF OPERATION** and **FIRE PREVENTION** distances!



**ATTENTION! The specified fire-protection distances – Pic. 21.– must be strictly kept and checked! The installation must comply with the valid standards! Disregard of these instructions can result in death, injury or property damage!**

HEAT-RADIATED AREA

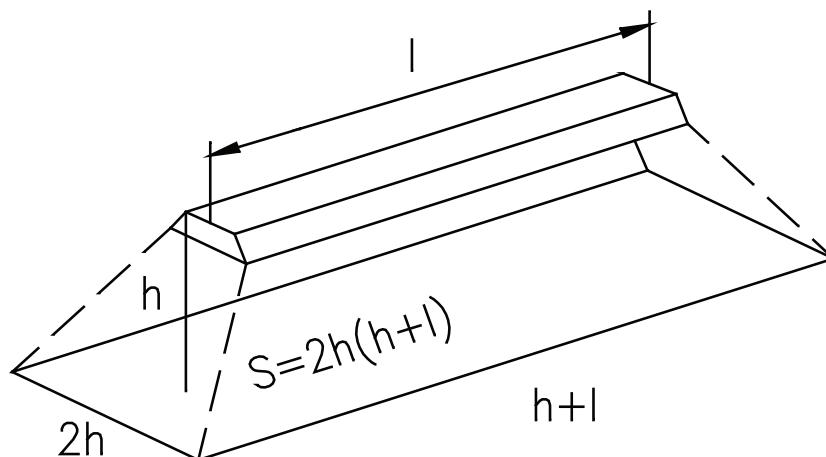

7.picture: Explanation of heat-radiated area

PROTECTIVE DISTANCES TO BE KEPT CONSIDERING FLAMMABLE MATERIALS:

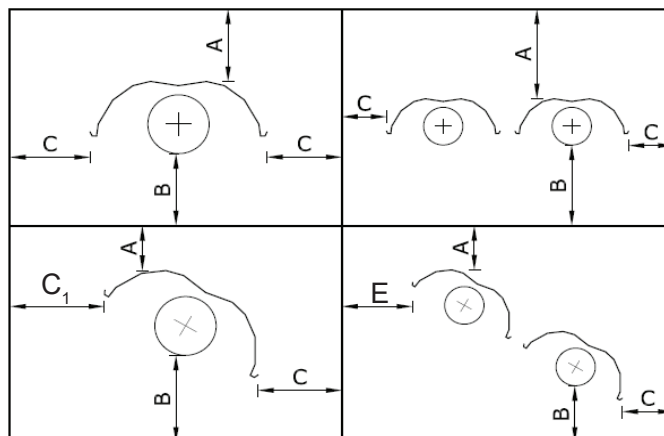

8.picture: Fire-protection distances

## THE MINIMAL MOUNTING HEIGHT

Type	Execution	Location	Input (kW) mounting height (m)										
			10	15	20	25	30	35	40	45	50	55	60
ZENIT	„U” FORM	horizontal	3,4	3,7	4	4,2	4,4	4,6	4,9	5,2	5,4	5,7	5,9
		30°	3	3,2	3,4	3,7	3,9	4,1	4,3	4,6	4,8	5	5,3
	„I” FORM	horizontal	3,2	3,5	3,7	4	4,2	4,5	4,7	5	5,2	5,4	5,6
		30°	2,7	3	3,2	3,4	3,6	3,9	4,1	4,3	4,5	4,7	4,9

## MINIMAL ASCENT OF INSTALLATION

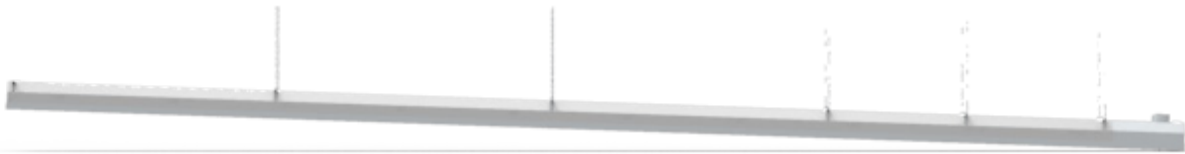

23.picture Minimal ascent of installation

## MAXIMAL ANGLE AT A COMPLETE APPLIANCE: (MAX.30°)



## SUSPENSION

After determining the number and exact position of appliances and hangers, you have to provide for hanging them at a minimum of 400 mm (hanging chains for example). This is necessary, so it does not hinder the length change, which increases during thermal expansion, - hereby appliances do not deform. Install hangers under the roof structure, under buttresses or scaffolding among columns or nearby wall. The suspension of appliances has to be executed by hanger located on the fan side of burner and combination brackets.

## EXAMPLE FOR LOCATION OF SUSPENSIONS

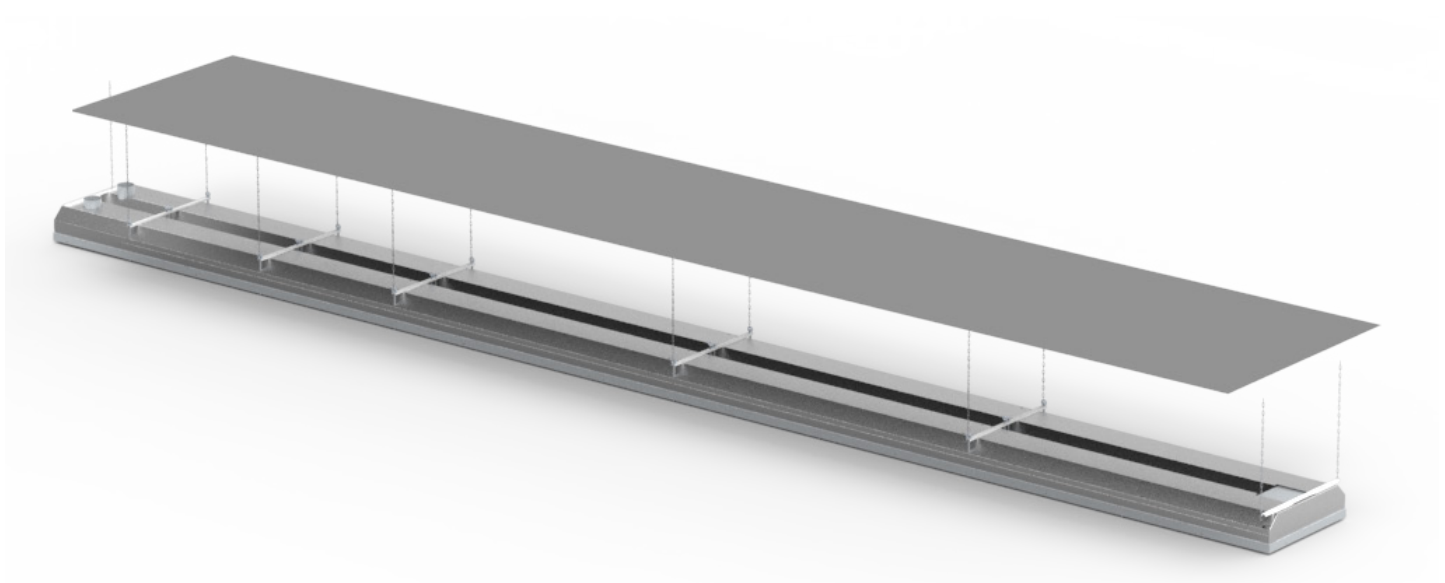

9.picture: Minimal installation height

At mounting take the correct hanging up of burner head into consideration because the improper hanging up can cause deformation on the burner head during heat dilatation.

## COMBUSTION-AIR SUPPLY

Combustion air may be drawn in from more spaces.

- from inside (heated) space
- from outside, in case outside combustion-air system is connected to the fan.

**The combustion air must not drawn in from internal space in the following cases:**

- if the heated building is under lower pressure than the outside
- if the atmosphere is contaminated with acid fumes, fluorocarbons, corrosive substances, dirt, oil, etc., which can damage the fan and pipe system

**In this case the combustion air must be conducted to the device from the external space.**

Tube length for combustion-air supply

6 meter with one elbow from 100 mm diameter tube.

15 m with two elbows from 150 mm diameter tube. More elbows can be used. One 90° elbow is correspond to 1 meter tube length

### EXAMPLE FOR OUTSIDE COMBUSTION-AIR SUPPLY:

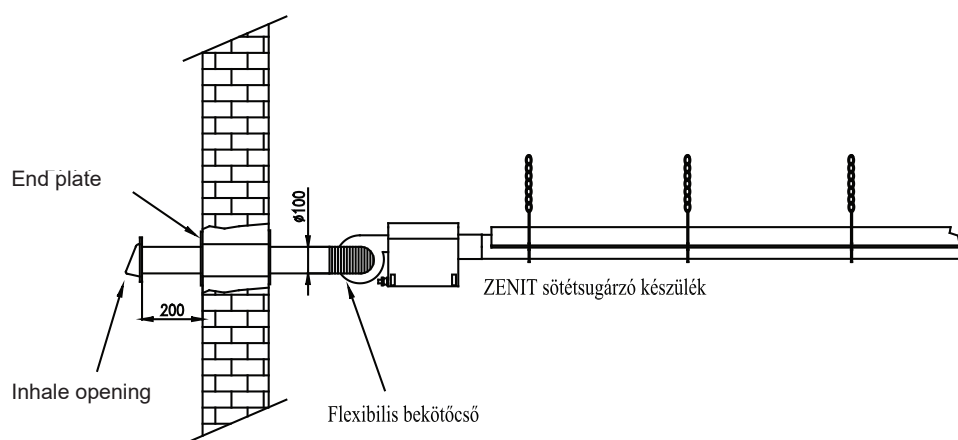

10.picture: Outside combustion-air supply

When two appliances are controlled by one thermostat in that case a common combustion-air supply can be used. The common duct of two appliance must be  $\varnothing$  150mm and should not exceed 15 m in length. Maximum two 90° elbows may be used.

## 6. EXHAUST SYSTEM POSSIBILITIES

Exhaust arrangements of combustion products

- Flue channel to the outside of building at each appliance
- Common flue channel for two appliances

*Flue pipe is not allowed to have a low point, it must be made of  $\varnothing$ 100mm stainless steel or aluminium. The minimum ascent of flue piping must be  $2\text{cm/m} \approx 1^\circ$*

Type of the exhaust system:

- Leading of combustion products across the wall
- Vertical leading of combustion products

The length of exhaust system:

The length of the exhaust system depend on the allowed maximal length and the used length of the appliance. The total length of exhaust system can be the difference of allowed maximum length (m) as per types (ZENIT-12...58) and the used length – at the installation – plus 6 m.

$L$  : Total length of exhaust system

$L_{\text{max}}$  : The allowed maximal length of appliance (it is defined as per types)

$L_{\text{used}}$  : The used length of appliance (at the installation)

$$L = L_{\text{MAX}} - L_{\text{used}} + 6 [\text{m}]$$

**The total length of exhaust system can be completed with 1pc 90° elbow without any correction.**

In case of using more 90° elbows the following correction has to be considered:

**Correction 1 pc 90° elbow = 1 m exhaust tube** (combustion products leading tube)

Namelly using more than one 90° elbow the length of exhaust system has to be proportionally reduced with the corrective value.

**If the entire length of conducting the combustion product specified previously is maximum 6 meters, according to the formula, but it is not sufficient for discharge, longer flue gas pipe can also be employed. In such cases the maximum equipment length + the fume discharge can be 30 meters in aggregate, but the flue gas pipe section above 6 meters must always be heat insulated!**

The exit module of exhaust system must be at least higher than 1 m from openings (sucking hole of vent etc.) of force-assisted ventilation systems. The bottom side of exit opening must be minimum from 30 cm any kind of frontal wall-protruding.

### EXHAUST SYSTEM ACROSS THE WALL

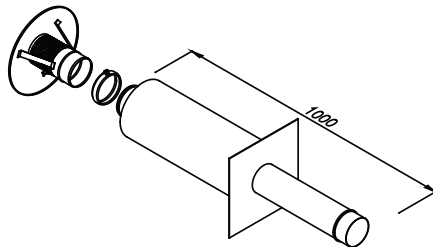

11.picture: Side-wall exit module

The examples of flue leading are suitable but can not conform to the standards of every country.

Examples for different flue leading:

#### A) SIDE-WALL EXIT FLUE (B23)

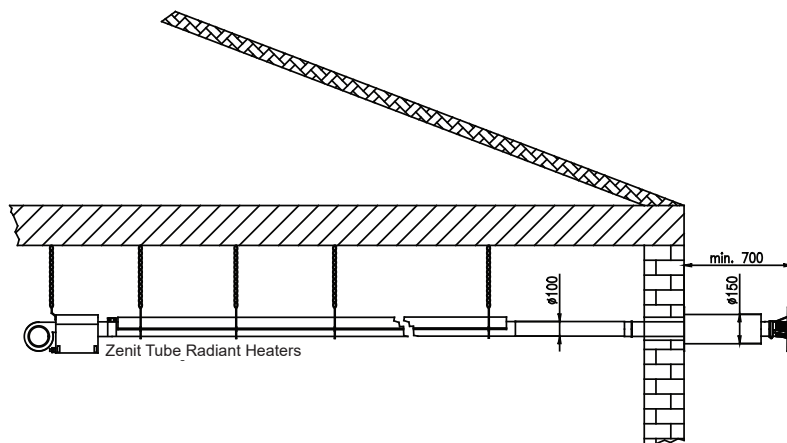

12.picture: Flue leading across wall

#### B) FLAT ROOF EXIT FLUE (B23)

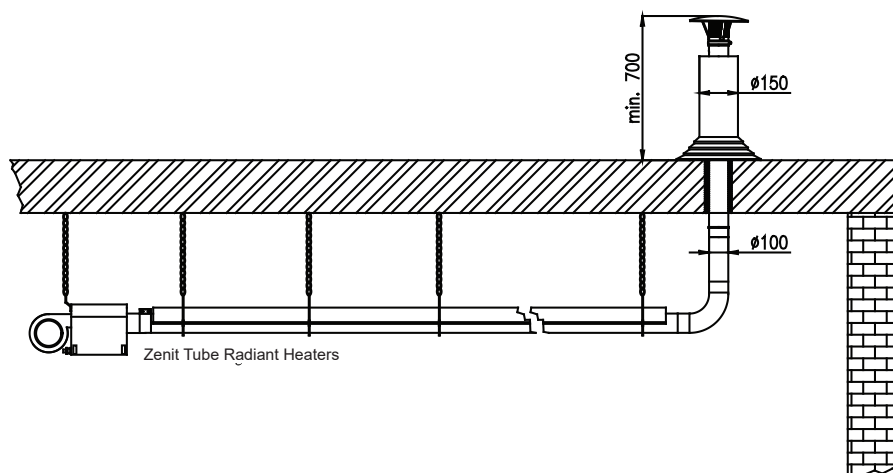

13.picture: Flue leading across flat roof

C) SLANTING ROOF EXIT FLUE (B23)

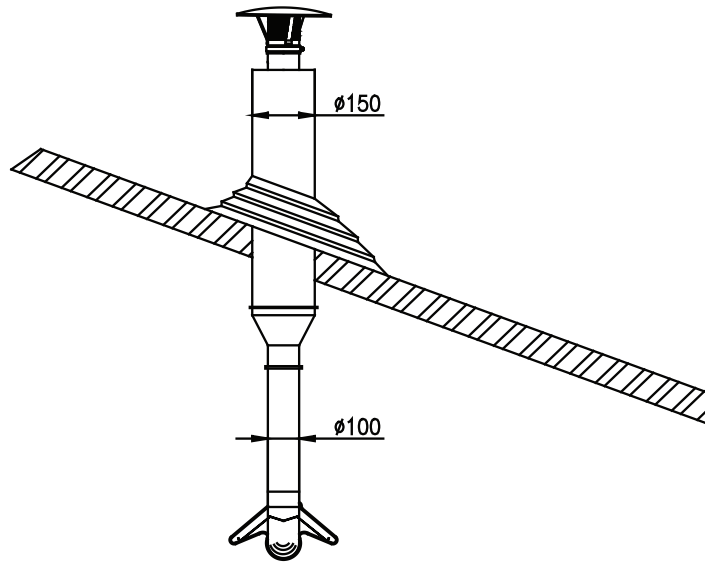

14.picture: Flue leading across slanting roof

D) APPLIANCES WITH COMMON EXIT FLUE (B33)

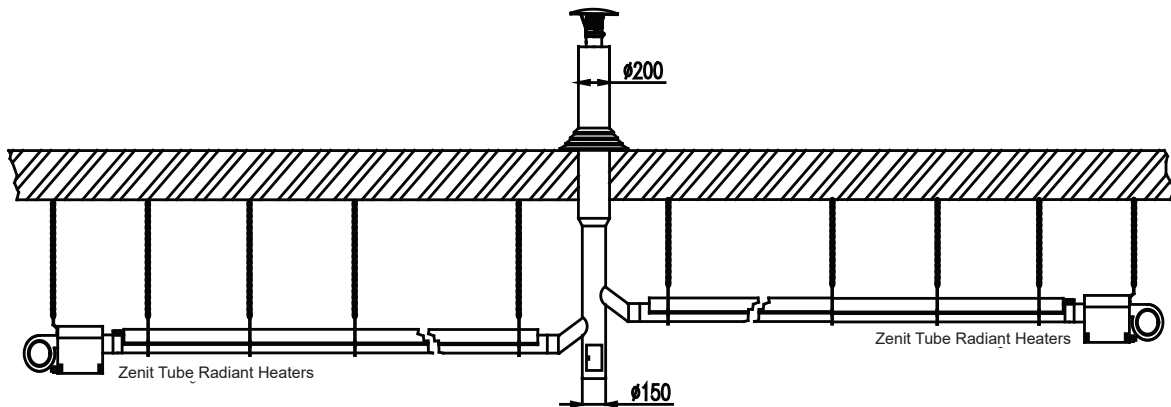

15.picture: Common flue vent set

**EXHOUST OUT TAKING +COMBUSTION AIR INTAKING**

A) COAXIAL SIDE WALL FLUE VENT SET (C13)

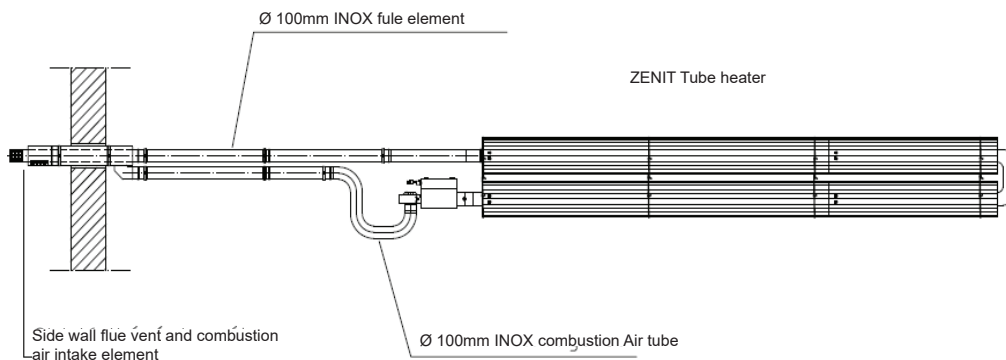

16.picture: Side-wall flue vent set

B) COAXIAL ROOF VENT SET (C33)

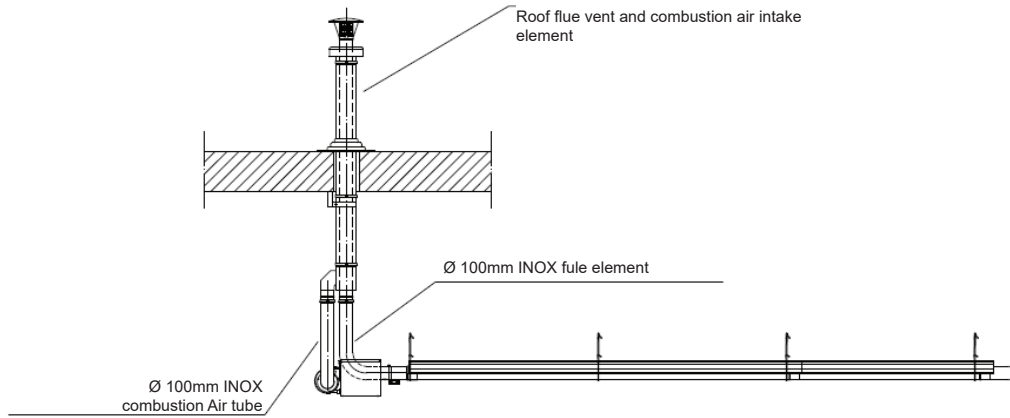

17.picture: Coaxial roof vent set

C) LINEAR TYPE TUBE HEATER WITH CLOSED BURNING FLUE VENT SYSTEM (C53)

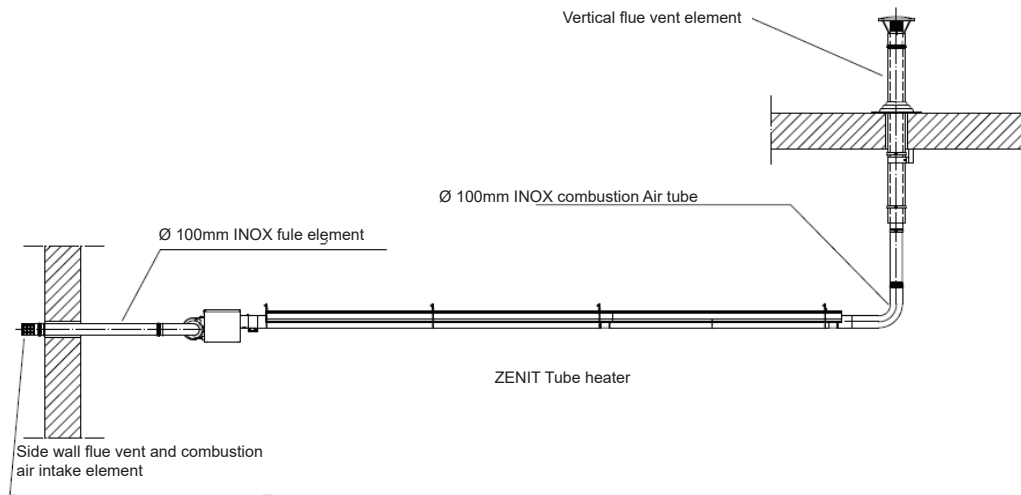

18.picture: Closed burning flue vent system

D) COMMON FLUE VENT SET FOR CLOSED BURNING SYSTEM (C83)

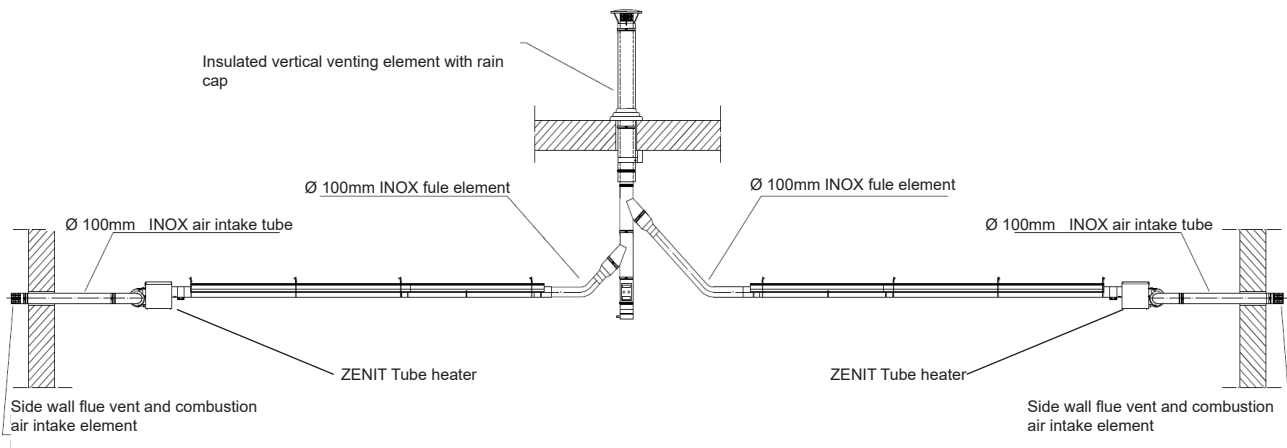

19.picture: Common flue vent set

## 7. APPLIANCE OPERATION

**ATTENTION!** The installation of appliance must be only executed by qualified service or specialist authorized by retailer. The 2 years guarantee of appliance can be ensured only in this case.

Before putting operation of appliance the leak-proof/pressure test of gas supply system must be fulfilled.

- Clean duct system of gas supply from any contamination.
- Check the presence and cleanness of gas filter located before the appliance
- Check the presense and suitability of pressure regulator located centrally or before every appliance.( the pressure regulator is needed if the gas supply pressure is higher than 60mbar,in this way the capacity of pressure regulator can be max.60mbar)
- Make sure of protective ground of appliance.
- Check the proper electrical connection of temperature regulator.
- Open the gas supply valve.
- Check the gas pressure on the inlet side of solenoid valve.(the maximum allowed pressure is 60mbar).
- Connect the mains voltage to the appliance (by temperature regulator or central stage main-switch).
- Check the outlet pressure of solenoid valve,whether the set up pressure – nozzle pressure – is suitable for the type of gas.
- At Natural gas – depending on output: 8.6, 9.5 vagy 10 mbar
- At „S” gas – depending on output: 8.6, 10, 11, 11.8, vagy 12.5 mbar
- At Propane and butane: 24.9 mbar

## 8. APPLIANCE SPECIFICATION

### START, RESTART

Following the switched on voltage the fan operates continuously assuring the 30 seconds prepurge time. This time period ensures the three times air change of combustion volume in case of biggest appliance's power.

When the pressure is suitable - after 30 seconds – the sparking happens and the solenoid valve opens in this way the gas catches fire.

### OPERATION OF AUTOMATIC BURNER CONTROL ( SIT 579 DBC TYP)

The flame sensor is self-monitoring and only performs an intervention on the burner it controls, insensitive to other environmental effects (eg.: external heat, light)

Following the switched on voltage the fan operates continuously assuring the 30 seconds prepurge time. This time period ensures the three times air change of combustion volume in case of biggest appliance's power.

When the pressure is suitable - after 30 seconds – the sparking happens and the solenoid valve opens in this way the gas catches fire.

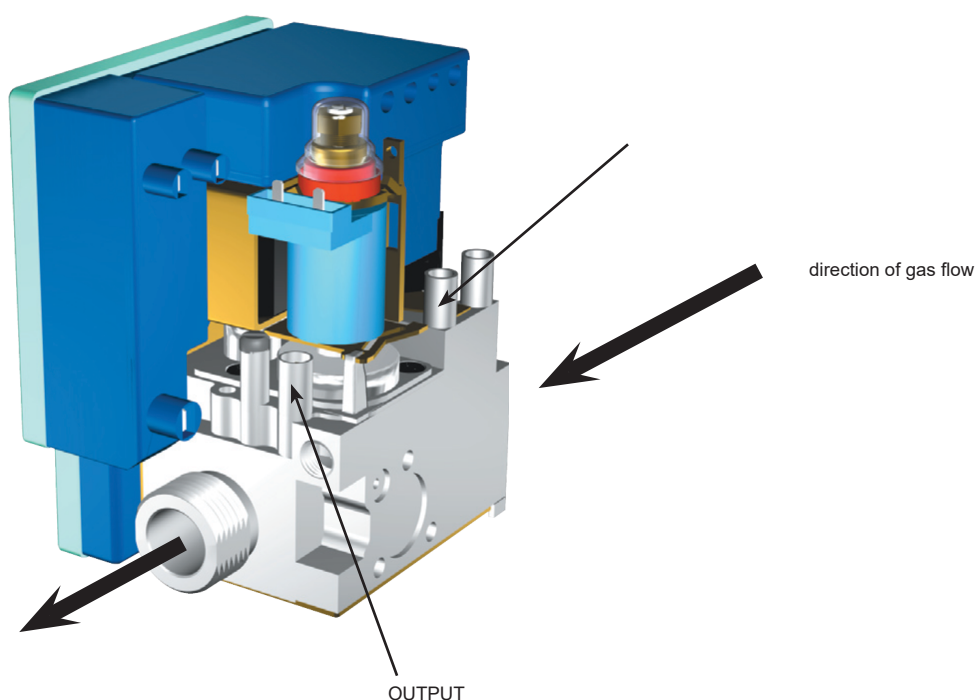

20.picture: Input and output gas pressure cheking connections in case of SIT solenoid valve



In case during 5 seconds sparking (ignition) the continuous flame shape is stabilized, - and stable electrical signal is come back from the electrode – the appliance operates and the green control lamp is lighting. During operation of appliance its automatic burner control controls the condition of differential pressure switch and signals coming from the flame control continuously, and if the position of differential pressure switch is changed – it is switched over from work position to rest – or the signal from the ionization flame control is interrupted then it stops the gas supply of burner. The fan continues to rotate, none of control lamps is lighting.

In case during the burning process the pressure decrease under the permissible minimal value on the positive side of air pressure (from the fan side), then automation prohibits:

- gas supply and fan stops

The fan continues to rotate, none of control lamps is lighting.

In case during burning process the pressure increases above the permissible maximum value on the negative side of air pressure switch (from the burner tube side, eg.at combustion back),then it switches back to rest position and the automation prohibits.

- gas supply and fan stops

The appliance stands into error position and red control lamp is lighting.

**Restart is possible after the switching off and on of mains voltage.**

## 9. MAINTANCE



**WARNING! Before every maintenance the appliance must be detached from the electrical supply and the gas supply must be turned off!  
Disregard of these instructions can result in death, injury or property damage!**

### CHECK AT THE BEGINNING OF SEASON

Carry out starting test and check the regular operation of appliance.

Checking of the regular operation.

Two kind of supervision should be fulfilled:

- a) Switch on the appliance, let it operate some minutes, then turn off the gas valve. The burner stops the operation. Wait for 6-8 seconds, then turn on the gas valve once more, the appliance starts the operation again..
- b) Let it operate some minutes. Then take down the exhaust end of heat radiant tubes and close the vent opening. The differential pressure switch switches over to OFF position from ON. The automation closes the solenoid valve and the appliance stops and red control lamp is lighting.

Remove the closing of tube and reset the original condition. Start the appliance again by interruption then reconnecting of mains voltage.

### MAINTENANCES

The ZENIT 80+ -type tube radiant heater appliance apart from the supervision and cleaning of radiant tubes (see: Maintenance supervision by the customer), do not need extra maintenances but to be able to preserve the SAFETY OPERATION and LONG LIFETIME of appliance it is recommended to have yearly supervision done by qualified service department.

#### MAINTENANCE SUPERVISION MUST INCLUDE THE FOLLOWING:

Maintenance supervisions by the customer

- a) Supervision and cleaning of heat radiant tubes.  
Clean the external surface of tubes from any dust by a brush and make sure that there is not any burnout or warping.
- b) Check connection and sealing of burner tube and heat radiant tubes by a survey. In case there is lack of sealing, colouring shows it.
- c) Check the condition of reflectors if necessary clean them. Clean them by a soft cloth or diluted detergent.
- d) Check the suspensions, make sure that the load is distributed smoothly at all mountings. You can check it moving each hanger a little.
- e) Cleaning the flue pipes.

Remove the barrier by the combustion product and reset the original condition

Restart the device by interrupting and resetting the power supply.

It is advisable to make a maintenance contract for the proper maintenance or call our qualified service department for regular maintenance.



**ATTENTION! Before any maintenance operation the appliance must be disconnected from the power supply by turn off the electrical main switch and pull out the electrical plug on the back of the appliance.**



**ATTENTION! In case operational circumstances of appliance (atmosphere is contaminated with corrosive substances, dirt etc.) need it, then supervision and cleaning may have done more often! The main reason of this that the settled dirt on the radiant tubes can damage the efficiency of it and load the tubes hereby loading the suspensions of it significantly!**

### **MAINTENANCE SUPERVISIONS BY A QUALIFIED SERVICE DEPARTMENT (ALL KINDS OF INTERVENTIONS FOR WHICH DISASSEMBLY OF APPLIANCE IS NECESSARY)**

- a) Supervision of nozzle pressure (at the outlet of solenoid valve)
- b) Checking the condition of pressure regulator.
- c) Cleaning of gas filter.
- d) Checking the condition of differential pressure switch.
- e) Checking the presence of protective ground.
- f) Supervision of electrical connection.
- g) Supervision of combustion air fan.

Check, whether the wheel of fan is able to revolve free and remove the possible contaminations from revolving blades.

### **GAS CHANGE**



**ATTENTION! In case you would like to operate your appliance by another type of gas (e.g. by Natural gas instead of Propane gas), then contact the local authorized representative or a qualified service department!**



**ATTENTION! This operation can be made just the qualified service department or specialist, who is entrusted by the manufacturer!**



**ATTENTION! If an intervention needs the disassembling of burner turn to a qualified service department, which is authorized by the representative!  
Disregard of these instructions can result in death, injury or property damage!**

## **10. TROUBLESHOOTING**

The following control lamps located on the bottom side of appliance (burner head) indicates the mode :

- Green: operation
- Red: error

# 11. ENCLOSURE

## ENCLOSURE 1.: VARIETY-LIST OF ZENIT 80+ -TYPE TUBE RADIANT HEATERS

(Minimum and maximum pipe lengths allowed for full lengths)

ZENIT 80+ selection list of tube radiants									
Type	Input Power (kW)	Full length (m)							
		L	U	L	U	L	U	L	U
		9	4,5	12	6	15	7,5	18	9
		8,8	4,4	12	5,9	15	7,3	18	8,8
ZENIT 80+12/8	12,8/7,9	x	x	-	-	-	-	-	-
ZENIT 80+14/9,3	14,1/8,9	x	x	-	-	-	-	-	-
ZENIT 80+16/10,5	15,8/9,6	x	x	x	x	-	-	-	-
ZENIT 80+18/12	18,3/10,6	x	x	x	x	-	-	-	-
ZENIT 80+20/13,4	20,4/11,6	x	x	x	x	x	x	-	-
ZENIT 80+22/14,7	21,9/12,8	x	x	x	x	x	x	-	-
ZENIT 80+24/16	24,4/14,8	-	-	x	x	x	x	x	x
ZENIT 80+26/17,4	26,2/15,9	-	-	x	x	x	x	x	x
ZENIT 80+28/18,7	28,4/16,8	-	-	x	x	x	x	x	x
ZENIT 80+30/20,1	30,6/17,8	-	-	x	x	x	x	x	x
ZENIT 80+32/21,4	31,9/19,1	-	-	-	-	x	x	x	x
ZENIT 80+34/22,8	33,8/20,1	-	-	-	-	x	x	x	x
ZENIT 80+36/24	36,2/21,1	-	-	-	-	x	x	x	x
ZENIT 80+38/25,4	38,4/21,9	-	-	-	-	x	x	x	x
ZENIT 80+40/26,4	39,6/22,9	-	-	-	-	x	x	x	x
ZENIT 80+42/28,5	42,8/24,7	-	-	-	-	-	-	x	x

**ENCLOSURE 2.: HEATING AND CONSUMPTION VALUES OF ZENIT 80+ -TYPE TUBE RADIANT HEATERS**

Type	Input power (kW)	Gas consumption		
		m <sup>3</sup> /h	kg/h	
		Natural gas	PB	Propan
ZENIT 80+-12/8	12,8/7,9	1,34/0,83	1,07/0,66	1,03/0,64
ZENIT 80+-14/9,3	14,1/8,9	1,48/0,93	1,18/0,74	1,14/0,72
ZENIT 80+-16/10,5	15,8/9,6	1,66/1,01	1,32/0,8	1,28/0,78
ZENIT 80+-18/12	18,3/10,6	1,92/1,11	1,53/0,89	1,48/0,86
ZENIT 80+-20/13,4	20,4/11,6	2,14/1,22	1,7/0,97	1,65/0,94
ZENIT 80+-22/14,7	21,9/12,8	2,3/1,34	1,83/1,07	1,77/1,03
ZENIT 80+-24/16	24,4/14,8	2,56/1,55	2,04/1,24	1,97/1,2
ZENIT 80+-26/17,4	26,2/15,9	2,75/1,67	2,19/1,33	2,12/1,29
ZENIT 80+-28/18,7	28,4/16,8	2,98/1,76	2,37/1,4	2,3/1,36
ZENIT 80+-30/20,1	30,6/17,8	3,21/1,87	2,56/1,49	2,47/1,44
ZENIT 80+-32/21,4	31,9/19,1	3,35/2,01	2,67/1,6	2,58/1,54
ZENIT 80+-34/22,8	33,8/20,1	3,55/2,11	2,82/1,68	2,73/1,62
ZENIT 80+-36/24	36,2/21,1	3,8/2,22	3,03/1,76	2,93/1,71
ZENIT 80+-38/25,4	38,4/21,9	4,03/2,3	3,21/1,83	3,1/1,77
ZENIT 80+-40/26,4	39,6/22,9	4,16/2,4	3,31/1,91	3,2/1,85
ZENIT 80+-42/28,5	42,8/24,7	4,49/2,59	3,58/2,06	3,46/2

Model: **ZENIT 80+ 9m „L” Gas-fired overhead radiant tube heaters Linear shape**

Type of heating:	Radiant tube					
Fuel:	Gaseous	Type of fuel:	Natural Gas	Propane	Butane	Propane-Butane
Space heating emission NO <sub>x</sub>				<b>139,2</b>	mg/kWh <sub>input</sub> (GCV)	

Characteristics when operating with the preferred fuel only

Item	Symbol	Value	Unit	Item	Symbol	Value	Unit
<b>Heat output</b>				<b>Useful efficiency - GCV</b>			
Nominal heat output	$P_{nom}$	24,3	kW	Useful efficiency at nominal heat output	$\eta_{th,nom}$	82,40	%
Minimum heat output	$P_{min}$	14,8	kW	Useful efficiency at minimum heat output	$\eta_{th,min}$	81,10	%
Minimum heat output - as percentage of nominal heat output	--	60,8	%				
<b>Radiant factor</b>				<b>Envelop losses</b>			
Radiant factor at nominal heat output	$RF_{nom}$	64,1	%	Envelope insulation class	U	0,0	W/m <sup>2</sup> K
Radiant factor at minimum heat output	$RF_{min}$	62,3	%	Envelope loss factor	$F_{env}$	0,0	%
				Heat generator to be installed outside the heated area	Yes	No	<u>Possible</u>
<b>Auxiliary electricity consumption</b>				<b>Heat output control type</b>			
At Nominal heat output	$el_{max}$	0,10	kW	- Singl stage (ON-OFF)	<u>Yes</u>	No	
At minimum heat output	$el_{min}$	0,06	kW	- Two stage (100%-60%-OFF)	<u>Yes</u>	No	
In standby mode	$el_{sb}$	0,0	kW	- Modulated	<u>Yes</u>	No	
<b>Permanent pilot flame power requirement</b>							
Pilot flame power requirement (if applicable)	$P_{pilot}$	0,0	kW				
Contact details	PAKOLE Trade Kft. H-8000, Székesfehérvár, Börgöndi út, 8-10						

Model: **ZENIT 80+ 12m „L” Gas-fired overhead radiant tube heaters Linear shape**

Type of heating:	Radiant tube					
Fuel:	Gaseous	Type of fuel:	Natural Gas	Propane	Butane	Propane-Butane
Space heating emission NO <sub>x</sub>				<b>127,6</b>	mg/kWh <sub>input</sub> (GCV)	

Characteristics when operating with the preferred fuel only

Item	Symbol	Value	Unit	Item	Symbol	Value	Unit
<b>Heat output</b>				<b>Useful efficiency - GCV</b>			
Nominal heat output	$P_{nom}$	34,0	kW	Useful efficiency at nominal heat output	$\eta_{th,nom}$	82,70	%
Minimum heat output	$P_{min}$	20,5	kW	Useful efficiency at minimum heat output	$\eta_{th,min}$	81,10	%
Minimum heat output - as percentage of nominal heat output	--	60,3	%				
<b>Radiant factor</b>				<b>Envelop losses</b>			
Radiant factor at nominal heat output	$RF_{nom}$	66,1	%	Envelope insulation class	U	0,0	W/m <sup>2</sup> K
Radiant factor at minimum heat output	$RF_{min}$	63,3	%	Envelope loss factor	$F_{env}$	0,0	%
				Heat generator to be installed outside the heated area	Yes	No	<u>Possible</u>
<b>Auxiliary electricity consumption</b>				<b>Heat output control type</b>			
At Nominal heat output	$el_{max}$	0,10	kW	- Singl stage (ON-OFF)	<u>Yes</u>	No	
At minimum heat output	$el_{min}$	0,06	kW	- Two stage (100%-60%-OFF)	<u>Yes</u>	No	
In standby mode	$el_{sb}$	0,0	kW	- Modulated	<u>Yes</u>	No	
<b>Permanent pilot flame power requirement</b>							
Pilot flame power requirement (if applicable)	$P_{pilot}$	0,0	kW				
Contact details	PAKOLE Trade Kft. H-8000, Székesfehérvár, Börgöndi út, 8-10						

Model: **ZENIT 80+ 15m „L” Gas-fired overhead radiant tube heaters Linear shape**

Type of heating:	Radiant tube					
Fuel:	Gaseous	Type of fuel:	Natural Gas	Propane	Butane	Propane-Butane
Space heating emission NO <sub>x</sub>				<b>141,1</b>	mg/kWh <sub>input</sub> (GCV)	

Characteristics when operating with the preferred fuel only

Item	Symbol	Value	Unit	Item	Symbol	Value	Unit
<b>Heat output</b>				<b>Useful efficiency - GCV</b>			
Nominal heat output	$P_{nom}$	43,9	kW	Useful efficiency at nominal heat output	$\eta_{th,nom}$	82,30	%
Minimum heat output	$P_{min}$	26,7	kW	Useful efficiency at minimum heat output	$\eta_{th,min}$	81,20	%
Minimum heat output - as percentage of nominal heat output	--	60,7	%				
<b>Radiant factor</b>				<b>Envelop losses</b>			
Radiant factor at nominal heat output	$RF_{nom}$	66,9	%	Envelope insulation class	U	0,0	W/m <sup>2</sup> K
Radiant factor at minimum heat output	$RF_{min}$	64,5	%	Envelope loss factor	$F_{env}$	0,0	%
				Heat generator to be installed outside the heated area	Yes	No	<u>Possible</u>
<b>Auxiliary electricity consumption</b>				<b>Heat output control type</b>			
At Nominal heat output	$el_{max}$	0,10	kW	- Singl stage (ON-OFF)	<u>Yes</u>	No	
At minimum heat output	$el_{min}$	0,06	kW	- Two stage (100%-60%-OFF)	<u>Yes</u>	No	
In standby mode	$el_{sb}$	0,0	kW	- Modulated	<u>Yes</u>	No	
<b>Permanent pilot flame power requirement</b>							
Pilot flame power requirement (if applicable)	$P_{pilot}$	0,0	kW				
Contact details	PAKOLE Trade Kft. H-8000, Székesfehérvár, Börgöndi út, 8-10						

Model: **ZENIT 80+ 18m „L” Gas-fired overhead radiant tube heaters Linear shape**

Type of heating:		Radiant tube					
Fuel:	Gaseous	Type of fuel:	Natural Gas	Propane	Butane	Propane-Butane	
Space heating emission NO <sub>x</sub>				<b>134,7</b>	mg/kWh <sub>input</sub> (GCV)		
Characteristics when operating with the preferred fuel only							
Item	Symbol	Value	Unit	Item	Symbol	Value	Unit
<b>Heat output</b>				<b>Useful efficiency - GCV</b>			
Nominal heat output	$P_{nom}$	47,5	kW	Useful efficiency at nominal heat output	$\eta_{th,nom}$	81,75	%
Minimum heat output	$P_{min}$	28,8	kW	Useful efficiency at minimum heat output	$\eta_{th,min}$	80,90	%
Minimum heat output - as percentage of nominal heat output	--	60,7	%				
<b>Radiant factor</b>				<b>Envelop losses</b>			
Radiant factor at nominal heat output	$RF_{nom}$	67,7	%	Envelope insulation class	U	0,0	W/m <sup>2</sup> K
Radiant factor at minimum heat output	$RF_{min}$	65,8	%	Envelope loss factor	$F_{env}$	0,0	%
				Heat generator to be installed outside the heated area	Yes	No	<u>Possible</u>
<b>Auxiliary electricity consumption</b>				<b>Heat output controll type</b>			
At Nominal heat output	$el_{max}$	0,10	kW	- Singl stage (ON-OFF)	<u>Yes</u>	No	
At minimum heat output	$el_{min}$	0,06	kW	- Two stage (100%-60%-OFF)	<u>Yes</u>	No	
In standby mode	$el_{sb}$	0,0	kW	- Modulated	<u>Yes</u>	No	
<b>Permanent pilot flame power requirement</b>							
Pilot flame power requirement (if applicable)	$P_{pilot}$	0,0	kW				
Contact details	PAKOLE Trade Kft. H-8000, Székesfehérvár, Börgöndi út, 8-10						



Model: **ZENIT 80+ 4,5m „U” Gas-fired overhead radiant tube heaters Linear shape**

Type of heating:	Radiant tube					
Fuel:	Gaseous	Type of fuel:	Natural Gas	Propane	Butane	Propane-Butane
Space heating emission NO <sub>x</sub>				<b>128,7</b>	mg/kWh <sub>input</sub> (GCV)	

Characteristics when operating with the preferred fuel only

Item	Symbol	Value	Unit	Item	Symbol	Value	Unit
<b>Heat output</b>				<b>Useful efficiency - GCV</b>			
Nominal heat output	$P_{nom}$	24,30	kW	Useful efficiency at nominal heat output	$\eta_{th,nom}$	82,70	%
Minimum heat output	$P_{min}$	14,20	kW	Useful efficiency at minimum heat output	$\eta_{th,min}$	81,60	%
Minimum heat output - as percentage of nominal heat output	--	58,4	%				
<b>Radiant factor</b>				<b>Envelop losses</b>			
Radiant factor at nominal heat output	$RF_{nom}$	66,3	%	Envelope insulation class	U	0,0	W/m <sup>2</sup> K
Radiant factor at minimum heat output	$RF_{min}$	62,4	%	Envelope loss factor	$F_{env}$	0,0	%
				Heat generator to be installed outside the heated area	Yes	No	<u>Possible</u>
<b>Auxiliary electricity consumption</b>				<b>Heat output control type</b>			
At Nominal heat output	$el_{max}$	0,10	kW	- Singl stage (ON-OFF)	<u>Yes</u>	No	
At minimum heat output	$el_{min}$	0,06	kW	- Two stage (100%-60%-OFF)	<u>Yes</u>	No	
In standby mode	$el_{sb}$	0,0	kW	- Modulated	<u>Yes</u>	No	
<b>Permanent pilot flame power requirement</b>							
Pilot flame power requirement (if applicable)	$P_{pilot}$	0,0	kW				
Contact details	PAKOLE Trade Kft. H-8000, Székesfehérvár, Börgöndi út, 8-10						

Model: **ZENIT 80+ 6m „U” Gas-fired overhead radiant tube heaters Linear shape**

Type of heating:	Radiant tube					
Fuel:	Gaseous	Type of fuel:	Natural Gas	Propane	Butane	Propane-Butane
Space heating emission NO <sub>x</sub>				<b>146,2</b>	mg/kWh <sub>input</sub> (GCV)	

Characteristics when operating with the preferred fuel only

Item	Symbol	Value	Unit	Item	Symbol	Value	Unit
<b>Heat output</b>				<b>Useful efficiency - GCV</b>			
Nominal heat output	$P_{nom}$	33,96	kW	Useful efficiency at nominal heat output	$\eta_{th,nom}$	82,90	%
Minimum heat output	$P_{min}$	18,64	kW	Useful efficiency at minimum heat output	$\eta_{th,min}$	81,70	%
Minimum heat output - as percentage of nominal heat output	--	54,9	%				
<b>Radiant factor</b>				<b>Envelop losses</b>			
Radiant factor at nominal heat output	$RF_{nom}$	67,7	%	Envelope insulation class	U	0,0	W/m <sup>2</sup> K
Radiant factor at minimum heat output	$RF_{min}$	63,9	%	Envelope loss factor	$F_{env}$	0,0	%
				Heat generator to be installed outside the heated area	Yes	No	<u>Possible</u>
<b>Auxiliary electricity consumption</b>				<b>Heat output control type</b>			
At Nominal heat output	$el_{max}$	0,10	kW	- Singl stage (ON-OFF)	<u>Yes</u>	No	
At minimum heat output	$el_{min}$	0,06	kW	- Two stage (100%-60%-OFF)	<u>Yes</u>	No	
In standby mode	$el_{sb}$	0,0	kW	- Modulated	<u>Yes</u>	No	
<b>Permanent pilot flame power requirement</b>							
Pilot flame power requirement (if applicable)	$P_{pilot}$	0,0	kW				
Contact details	PAKOLE Trade Kft. H-8000, Székesfehérvár, Börgöndi út, 8-10						

Model: **ZENIT 80+ 7,5m „U” Gas-fired overhead radiant tube heaters Linear shape**

Type of heating:		Radiant tube				
Fuel:	Gaseous	Type of fuel:	Natural Gas	Propane	Butane	Propane-Butane
Space heating emission NO <sub>x</sub>				<b>141,9</b>	mg/kWh <sub>input</sub> (GCV)	

Characteristics when operating with the preferred fuel only

Item	Symbol	Value	Unit	Item	Symbol	Value	Unit
<b>Heat output</b>				<b>Useful efficiency - GCV</b>			
Nominal heat output	$P_{nom}$	43,94	kW	Useful efficiency at nominal heat output	$\eta_{th,nom}$	82,10	%
Minimum heat output	$P_{min}$	25,41	kW	Useful efficiency at minimum heat output	$\eta_{th,min}$	81,20	%
Minimum heat output - as percentage of nominal heat output	--	57,8	%				
<b>Radiant factor</b>				<b>Envelop losses</b>			
Radiant factor at nominal heat output	$RF_{nom}$	67,6	%	Envelope insulation class	U	0,0	W/m <sup>2</sup> K
Radiant factor at minimum heat output	$RF_{min}$	65,4	%	Envelope loss factor	$F_{env}$	0,0	%
				Heat generator to be installed outside the heated area	Yes	No	<u>Possible</u>
<b>Auxiliary electricity consumption</b>				<b>Heat output control type</b>			
At Nominal heat output	$el_{max}$	0,10	kW	- Singl stage (ON-OFF)	<u>Yes</u>	No	
At minimum heat output	$el_{min}$	0,06	kW	- Two stage (100%-60%-OFF)	<u>Yes</u>	No	
In standby mode	$el_{sb}$	0,0	kW	- Modulated	<u>Yes</u>	No	
<b>Permanent pilot flame power requirement</b>							
Pilot flame power requirement (if applicable)	$P_{pilot}$	0,0	kW				
Contact details	PAKOLE Trade Kft. H-8000, Székesfehérvár, Börgöndi út, 8-10						

Model: **ZENIT 80+ 9m „U” Gas-fired overhead radiant tube heaters Linear shape**

Type of heating:	Radiant tube					
Fuel:	Gaseous	Type of fuel:	Natural Gas	Propane	Butane	Propane-Butane
Space heating emission NO <sub>x</sub>				<b>159,7</b>	mg/kWh <sub>input</sub> (GCV)	

Characteristics when operating with the preferred fuel only

Item	Symbol	Value	Unit	Item	Symbol	Value	Unit
<b>Heat output</b>				<b>Useful efficiency - GCV</b>			
Nominal heat output	$P_{nom}$	47,50	kW	Useful efficiency at nominal heat output	$\eta_{th,nom}$	82,49	%
Minimum heat output	$P_{min}$	27,41	kW	Useful efficiency at minimum heat output	$\eta_{th,min}$	81,10	%
Minimum heat output - as percentage of nominal heat output	--	57,7	%				
<b>Radiant factor</b>				<b>Envelop losses</b>			
Radiant factor at nominal heat output	$RF_{nom}$	67,9	%	Envelope insulation class	U	0,0	W/m <sup>2</sup> K
Radiant factor at minimum heat output	$RF_{min}$	65,15	%	Envelope loss factor	$F_{env}$	0,0	%
				Heat generator to be installed outside the heated area	Yes	No	<u>Possible</u>
<b>Auxiliary electricity consumption</b>				<b>Heat output control type</b>			
At Nominal heat output	$el_{max}$	0,10	kW	- Singl stage (ON-OFF)	<u>Yes</u>	No	
At minimum heat output	$el_{min}$	0,06	kW	- Two stage (100%-60%-OFF)	<u>Yes</u>	No	
In standby mode	$el_{sb}$	0,0	kW	- Modulated	<u>Yes</u>	No	
<b>Permanent pilot flame power requirement</b>							
Pilot flame power requirement (if applicable)	$P_{pilot}$	0,0	kW				
Contact details	PAKOLE Trade Kft. H-8000, Székesfehérvár, Börgöndi út, 8-10						

## GUARANTEE AND SERVICES

### PRESERVE THIS WARRANTY

Type: \_\_\_\_\_

Serial no.: \_\_\_\_\_

Date of purchasing: \_\_\_\_\_

### LIMITED GUARANTEE \*

The manufacturer guarantee the costumer that the product and its parts are free from material and production failures. During normal use the warranty is 2 years. This warranty concerns the first retail customer.

The guarantee concerns the costs of laboratory investigations and the parts, which are needed for proper operation. The delivery and unforeseeable costs belong also to the mending costs and do not contain compensation costs.

Guarantee mending can only be realized by authorized retailer or service centre.

The guarantee does not concerns the following failures, which are caused by: improper using, damaging, neglect, accident, lack of maintenance, normal attrition, transformation, modification and operation influenceable factor, contaminated fuel, installation of non-suitable part and mending which is done by not authorized retailer or service station.

The regular maintenance is the owner's responsibility.

The manufacturer does not assume the responsibility in case of accidentally happened or directly caused mistake respectively improper using.

\*We reserve the right to change of this specification without extra notification. The guarantee can be applied in accordance with above defined.  
Additional guarantee is not accepted.

### Guarantee servicing

If your appliance needs guarantee service in that case it can be requested at nearest authorized service station giving in the appliance for repairs.

### Mending services

Take the appliance to the nearest authorized service station. If the device is not under guarantee the service cost will be invoiced to the costumer at defined price. The service centres are independent from one another and may have different owners. We reserve the right to change of this specification without extra notification. If you would like to contact us the type and serial number of device

always be at hand. In case of other needed information write to the following address:

### PAKOLE TRADE Kft.

H-8000 Székesfehérvár, Börgöndi út 8-10.

Tel.: +36 22 316 484

Fax.: +36 22 316 074



[www.pakole.com](http://www.pakole.com)

---

**PAKOLE TRADE Ipari és Kereskedelmi Kft.**

H-8000 Székesfehérvár, Börgöndi út 8-10.

<http://www.pakole.com>

E-mail: [mail@pakole.hu](mailto:mail@pakole.hu)

Tel.: +36 22 316 484

Fax: +36 22 316 074