

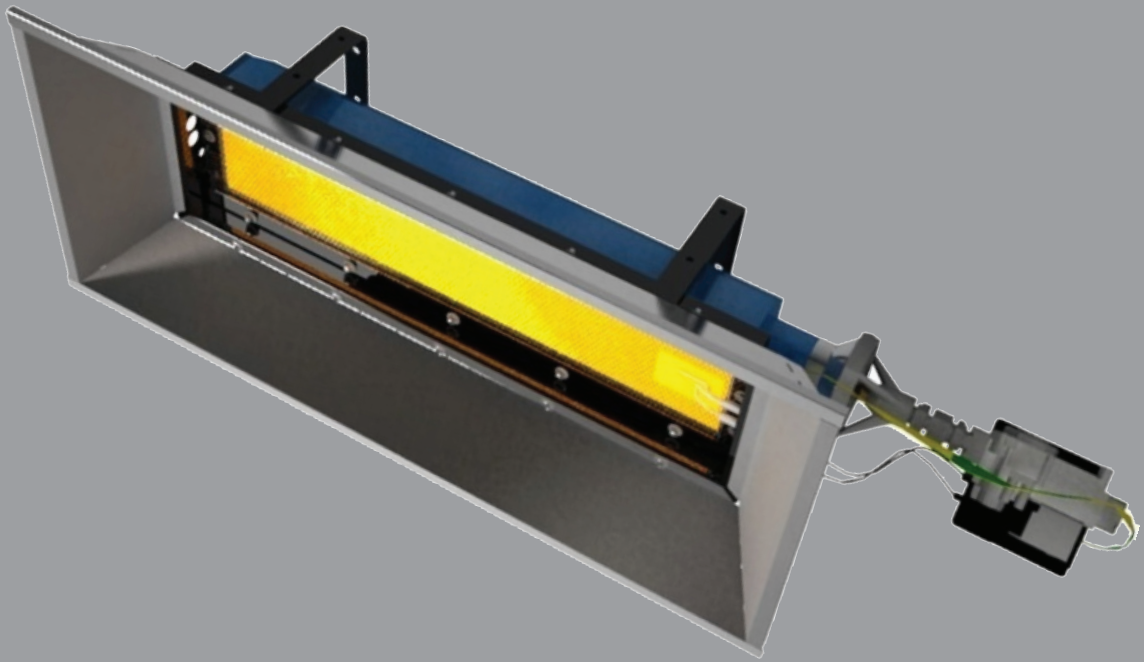

PAKOLE

USER'S MANUAL

**NATURAL OR PROPANE GAS WORKING
INFRARED CERAMIC HEATERS**



**Appliance types:
GH-7...36
(SIT, Honeywell)**

www.pakole.com

GH_009_008_011_220609_V003_en

EN

Table of Contents

1. SAFETY INFORMATION	3
2. GENERAL INSTRUCTION	4
Installer's responsibilities	4
Data board	4
Corrosive materials	5
Standards and laws	5
Safety signs	5
Safe usage	5
3. TRANSPORTATION, UNPACKING, HANDLING	6
Optional accessories	6
4. OPERATION PRINCIPLE	7
5. INSTALLATION	7
Drawings and dimensions of the appliances	7
Installation of gas infrared heaters and Safety instructions	8
Protective distances to be kept considering flammable materials	8
Necessary Ventilation	8
6. APPLIANCE OPERATION	8
7. MAINTENANCE	10
Maintenance types	10
Maintenance supervisions by the customer	10
Check at the beginning of season	10
Maintenance supervisions by a qualified service department	10
Gas change	10
8. TROUBLESHOOTING	11
9. ENCLOSURE	12
Enclosure 1.: Type and technical data of infrared heater	12
Enclosure 2.: gas consumption of GH heaters	12
Enclosure 3.: Target countries/gas categories	13

1. SAFETY INFORMATION



Read and understand this manual thoroughly before installing starting or servicing this equipment. The improper installation or using can cause serious damages! Keep this manual in a safe place in order to obtain information in case of incidental problems!



GENERAL SAFETY NOTICES

Disregard of instructions and notices of this Manual can cause serious bodily injuries or damages as follows: burning, explosion, suffocation, carbon monoxide poisoning, electric shock and in extreme case death!

This appliance can only be used and serviced by such persons who understood and follow the instructions of this Manual. If you need help or information concerning the appliances – for example installation guide or labels etc. – in that case contact with the manufacturer!

This appliance must not be used by children and mentally or sensitively deficient persons! Take care that the children do not handle it and do not play with devices!



ATTENTION! Fire, burning, inhalation and explosion hazard! Keep all flammable objects as follows building materials, papers, or carton unites away from heater according to the instructions! Never use this appliance in such rooms where there are flammable volatile materials or the following materials, which can get into the device: petrol, solvent, thinner, fine grained dusty or unknown chemical materials!



ATTENTION! For your safety, if you smell gas do the followings:

- **Open windows.**
- **Do not try to light any appliance.**
- **Do not use electrical switches.**
- **Do not use any telephone in your building.**
- **Leave the building.**
- **Immediately call your local gas supplier after leaving the building. Follow the gas supplier's instructions.**
- **If you cannot reach your gas supplier, call the Fire Department.**

GH type heaters do meet the requirements of EN 419 standard. When properly applied, the unit guarantees a safe and energy-efficient operation! Flue gasses of combustion are not drained, therefore continuous fresh air exchange must be ensured (detailed description see in chapter "Devices specifications").

Our GH product range is compliant to the COMMISSION REGULATION (EU) 2015/1188 of 28 April 2015 implementing Directive 2009/125/EC of the European Parliament and of the Council with regard to Ecodesign requirements for local space heaters for start-up, operation and use solely under legal conditions permitted under Article 1 (b) of this Regulation.

(Article 1 (b) of Regulation (EU) 2015/1188):

„Local space heaters specified for purposes other than indoor space heating to reach and maintain a certain thermal comfort of human beings by means of heat convection or heat radiation“)

In view of the above, our company neither as a manufacturer, nor as distributor or installer disclaim any responsibility for the operation and use of the product for purposes other than described in Article 1 (b) of this regulation.

We consider it to be a consistent expression of our non-liability statement if you do not make a limitation or exclusion statement after.

Other local regulations in your country provide appropriate guidance on the correct use of gas or propane gas, such as supply, storage, etc.

Carbone-monoxide poisoning: The initial symptoms of carbone-monoxide poisoning are similar to influenza namely headache, dizziness and/or nausea! If these symptoms are observed in that case the appliance probably does not work satisfactorily! First of all go fresh air, ventilate the rooms and have the appliance investigated!

Propane-gas: The propane-gas is odourless! Mercaptan-derivative as scented component is mixed into the gas to be able to observe the possible escape! In spite of the typical smell is not felt the propane gas can be present in the environmental air in case of escaping!

2. GENERAL INSTRUCTION



- Make sure that read and understood all the warnings, correct keeping of which can guarantee the safety and faultless operation!
- During the installation be always circumspect! Follow the valid instructions and recommendations!
- The appliance can be operated by specified voltage and frequency marked on its data board! The electrical connections and groundings are prepared as per MSZ EN 60335 standard!
- Electrical grounding specification: present appliance is equipped with three points grounding connection in the interests of your protection!
- It needed to ensure the sufficient quantity of combustion air if the appliance is installed without outside air supply!
- Keep away the device from the following strong effects: wind, high pressure water jet, rain or dropping water!
- The appliance must not be used in the open air!
- The application of device is STRICTLY PROHIBITED in such rooms, which are used for sleep or continuous stay!
- Keep away the flammable materials from the appliance and its near environment as follows: fuels, thinner or other flammable fluids and vapours!
- In the interests of avoiding of dust explosion do not used the device in such rooms where the degree of dust concentration is high if the device is installed without outside air supply!
- Before starting of appliance in every case check it in order to detect the possible damages! Never use damaged equipment!
- In case of Propane-gas operation never install the device in basement or from that lower being rooms! The propane-gas is heavier specific gravity than the air for this reason in case of possible escaping it will spread towards the lower located rooms!
- Only use that kind of flexible gas pipe and pressure regulator, which is offered for the appliance by the manufacturer!
- Before every starting of heater appliance check the condition of connecting gas hose and if it is particularly worn or damaged in that case exchange it for a new one specified by manufacturer!
- Preserve the equipment in genuine condition, do not leave it to grow old!
- Do not use seriously aged equipments any longer!
- Fix the appliance on such stable surface, which during operation despite warming of appliance preserves its stability!

INSTALLER'S RESPONSIBILITIES

- making up of gas and electrical connection in compliance with the specifications (it is proposed to connect with the local Building Supervisory Authority or Fire-service),
- installation of equipment in accordance with the definitions of this manual,
- installation according to the fire prevention rules,
- supply of the necessary materials/components for installation(which are not belong to appliance),
- planing of air duct systems (ventilation/connections)
- service execution,
- placing the copy of present manual at owner's disposal,
- assuring of sufficient air circulation around the appliance,
- determination and assuring of needed air for burning, ventilation and blowing in according to the specifications.

DATA BOARD

The appliance is equipped with data board, which is placed on outside of device's door. On this data board there are information concerning the type of device, gas type, electrical connection and flue types.

Manufacturer PAKOLE Trade Kft. 8000 Székesfehérvár, Börgöndi út 8-10.		Distribute: PAKOLE Trade Kft. 8000 Székesfehérvár, Börgöndi út 8-10.		 <small>UA.TR.012-10</small>  1008 14
Electrical protection: IP20		Type GH-36		
Electrical connection: AC 230V 50Hz		Nominal input: 36 kW		SVGW Nr. 12-001-3
Max.current entry: 0,15 A		Pconnecting max.: 60 mbar		
Electrical power: 35 W		Jet pressure: 16 mbar		
Category: I12H3+,I12H3P		Pconnecting min.: 20 mbar		<small>Date/place of production</small> 2018.03.20.
Series number: 13-137-P0001		Gas type: Naturalgas		
		Targeted country: GB		
		NOx: 4 PIN: 1009 CL 1599		

1. picture: Data board

CORROSIVE MATERIALS

ATTENTION! Do not use the appliance in such place where corrosive materials can be in the air! If the appliance has to be applied in this circumstances outside air has to be ensured for combustion air!

The manufacturer can not assume responsibility for fault of equipment in case the installation is not happened according to the above. This responsibility concerns completely the installer. In order to avoid such eventualities, if it is not certain to fit to the building or activity, ask our colleague for help

Both the owner and the installer have to identify every possible material, which can be present in the building (inflammable materials, corrosive materials, halo hydrocarbons etc.), and with knowledge of these materials must be planed the heater system!

STANDARDS AND LAWS

Every appliance installation must be satisfied the valid laws and standards. These laws refer to the gas and electrical installation respectively the ventilation (special specifications refer to park houses, airplane hangars etc).

SAFETY SIGNS

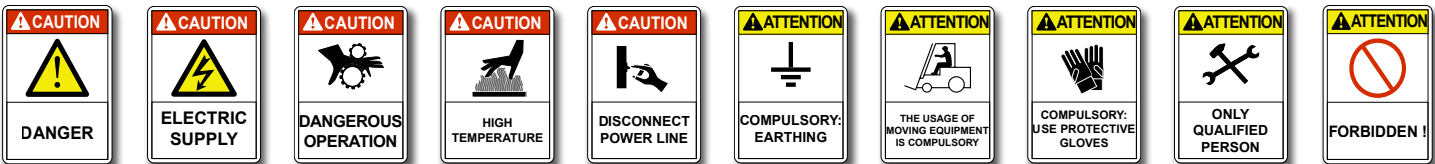

SAFE USAGE



Please observe the following rules during installation, first set-up, usage or maintenance:

- Installation must be carried out always strictly complying with the current standards of the country where the appliance is going to be used and following, of course, the instructions given by the producer.
- The installation and maintenance operations of the unit can be carried out by qualified and trained personnel only.

Qualified service engineers are those having specific technical experience and/or valid license in the field of heating and cooling installation for home and industry. In any case, call the Manufacturer office or the closest dealer (www.pakole.com) and ask for further informations.

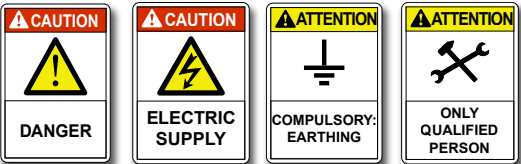

- According to the installation project, install the electric power lines.
- Always make sure that the unit and all its electrical parts have been correctly earthed prior starting up the unit.



- If you have to disassemble the unit, use special protective gloves.
- Beware of sharp edges inside the unit!
- Beware of roof corners of outdoor units!
- Keep suction grids always clear!



- Before cleaning or maintaining the unit, make sure that all electrical parts have been switched off, the appliance gas supply chain is closed and wait until the appliance cools down.

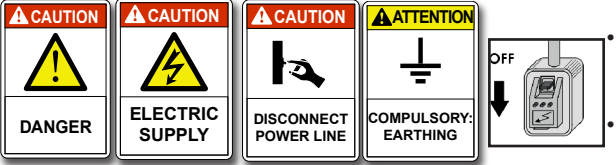

- We recommend to install a safety switch which can be easily reached to cut off the current, near the unit. Before any cleaning and servicing operation, cut off the power line to the unit.
- Before opening the unit, make sure that all electrical parts have been switched off.

CHECK THE EARTHING !!



- This unit is designed to be used for heating purposes only. Any different use is not allowed as it may be dangerous.
- Should the unit work in a house where disabled people and/or children live, it must be placed safely away from their reach. Always make sure that the access door to the inside control board stay locked.
- An incorrect installation can cause damages to people, animals and property. In case of erroneous installation, the manufacturer cannot be held responsible for such damages.
- **The manufacturer cannot be held responsible for such damages by improper uses, errate uses, etc.**



- Never use the unit to support other equipment.
- Never leave tools, spare parts, etc. inside the unit.
- Make sure that all inspection panels are closed properly.
- Do not expose the unit to inflammable gases.



- In case of breakdown or failure: turn unit off, do not try to repair it on your own, call operator.
- If you are going to leave the heater switched off for a long time, first make sure that in no way this could cause harm to anyone in any way.

3. TRANSPORTATION, UNPACKING, HANDLING

- The delivery must be made according to the following:
 - The package must be carefully secured in the loading space.
 - The package must be transferred in a closed space (always keep packing parts away environmental impacts).
- The unit has a special safety packing for transport and delivery which must be kept in good conditions till the unit is positioned on the installation place.
- Make sure that the unit has all its parts, as specified in the order.
- Check if there are any damages and if the unit abbreviation is the same as the one of the ordered model.
- Every unit is factory tested before shipment, therefore, if there are damages, report them immediately to the carrier.

Transporting, unloading and moving is a process which must be made carefully to avoid any kind of damages. Try not to use the unit's components as handholds. When lifting, bear in mind that the centre of gravity of the unit may be off-centre.



The appliances will be delivered in card board box as follows:

- gas ramp with gas magnetic valve and ignition control
- 4 pcs. aluminized reflector plates with all the necessary M5 heat resistance screws
- as well as this instruction manual and a declaration of conformity

The unpacking process of the appliance:

- unload the burner and the accessories from the card board box (assembly in the 5. chapter)
- **do not remove the protection cap from the burners gas connection or from the gas joining set (optional) until You do not connect it to the pipe line.**
- Check the unit and its accessories for any damages which could be arise during the transportation.
- if there are any damages found, report them immediately to the manufacturer or Your closest dealer.

There is an envelope inside the unit containing the Instructions for Installation and Servicing, User's Guide use and Guarantee and services and the warranty documents.

OPTIONAL ACCESSORIES

Recommended temperature controllers for the appliance (these can be purchased at the appliance manufacturer)

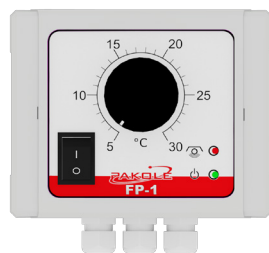

FP-1D typed thermostat



Temperature sensor



FP- 4D typed thermostat (programmable)

9.picture: Temperature controller

4. OPERATION PRINCIPLE

The appliance operates on the basis of radiant heating. Actually this is an atmospheric burner, where the gas and air mixture flow through the ceramic plate and the flame come into being in the holes of ceramic. The temperature of the surface of the ceramics is 850-900°C. This surface has a high radiant intensity and quick heat passing.

The construction of the equipment is not insure to lead away the being combustion product, so in this case necessary to build this type appliances in a well ventilated halls. (necessary air ventilating see on the 5. chapter)

The equipment takes the air from the hall for the burning process.

The variety-list of appliances to be found in the **enclosure 1**.

The heating and consumption values to be found in the **enclosure 2**. as per appliance and gas types.

5. INSTALLATION

DRAWINGS AND DIMENSIONS OF THE APPLIANCES

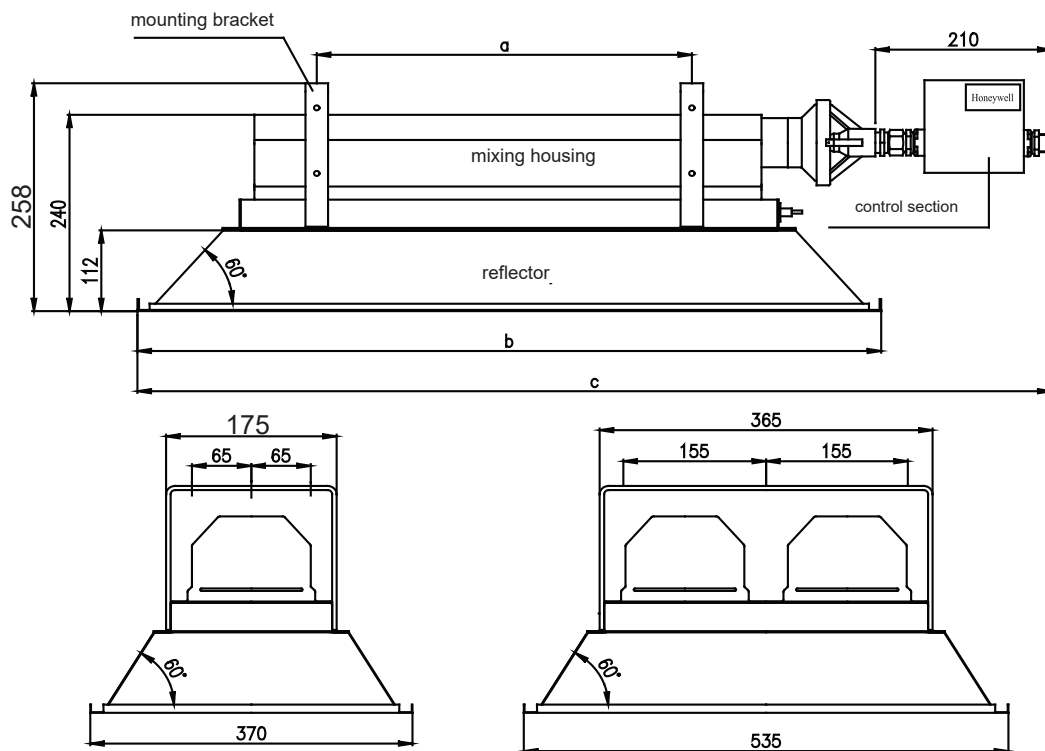

2.picture: Gas working infrared heaters types

Type	Design	a	b	c	Weight (kg)
GH-7/K	1 mixing house with manual ignition	245	600	796	9
GH-7	1 mixing house	245	600	830	9
GH-11	1 mixing house	414	789	1040	12,1
GH-18	1 mixing house	950	1150	1550	15,6
GH-23	2 mixing houses	414	789	1140	19
GH-36	2 mixing houses	950	1156	1540	28,2

INSTALLATION OF GAS INFRARED HEATERS AND SAFETY INSTRUCTIONS

Warning! DO NOT ALLOWED to install the GH appliances into "A" and "B" specified fire-protection class! The installation must comply with the valid standards! Disregard of these instructions can result in death, injury or property damage!

Infrared heaters are to be mounted on welded or assembled consoles built in the side wall of the hall to be heated, eventually on the ceiling, and secured with M8 bolts.

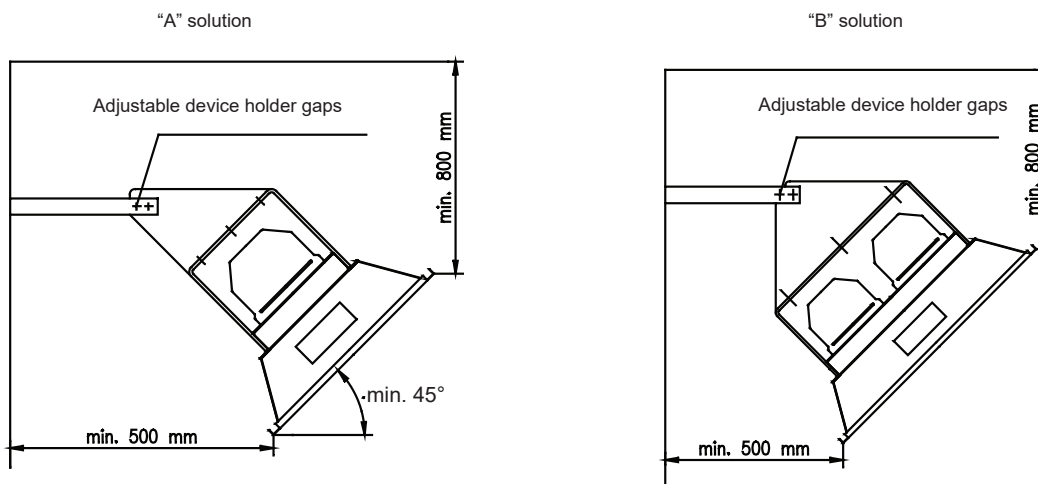

10. picture: Installation of the GH heaters and safety distances

Tilting angle of heater should be adjusted according to values given in referring plan. Most frequent values: 45° and 60°, which mean the pitch of ceramic flat to the floor. At hanging from the ceiling, at least 45° minimum tilting must be ensured! The minimal tilting what is allowed at GH-23 and GH-36 appliances is 45°!

PROTECTIVE DISTANCES TO BE KEPT CONSIDERING FLAMMABLE MATERIALS

The distance of any inflammable materials from the heater must be chosen with ensure, that the surface temperature of these materials could NOT reach 50 °C. In cases when it is not possible, a fireproof heat protection plate must be used.

NECESSARY VENTILATION

The heaters do not possess integral combustion product exhausting system, so must be ventilate the room.

Minimum 16 m³/h and maximum 24 m³/h air exchange is necessary at every built-in/kW.

6. APPLIANCE OPERATION

Warning! The installation of appliance must be only executed by qualified service or specialist authorized by retailer. The guarantee of appliance can be ensured only in this case.

Before putting operation of appliance the leak-proof/pressure test of gas supply system must be fulfilled. Clean duct system of gas supply from any contamination.

- Check the presence and cleanness of gas filter located before the appliance
- Check the presence and suitability of pressure regulator located centrally or before every appliance. (the pressure regulator is needed if the gas supply pressure is higher than 60 mbar, in this way the capacity of pressure regulator can be max. 60 mbar)
- Make sure of protective ground of appliance.
- Check the proper electrical connection of temperature regulator.
- Open the gas supply valve.
- Check the gas pressure on the inlet side of (magnetic) solenoid valve. (the maximum allowed pressure is 60 mbar).
- Connect the mains voltage to the appliance by temperature regulator or central stage main-switch.
- Check the outlet pressure of solenoid valve, whether the set up pressure – nozzle pressure – is suitable for the type of gas.

Adjustment of gas pressure happens only in that case, when device does not operate satisfactorily within the value adjusted by the manufacturer. Device is factory-adjusted, but because of the different positioning circumstances it is practical to adjust it after the on-the-spot installation. The characteristic heat technical data is only expected from well-adjusted devices. A qualified technician should make adjustment of heating device.

The first adjustment of the appliance must be carried out only from a well educated technician! To fulfil this requirement the easiest way if You order this procedure by the producer or by the nearest distributor. If You decide to order the first adjustment procedure by the producer or by the distributor please feel free to contact our colleagues!

The flame sensor is self-monitoring and only performs an intervention on the burner it controls, insensitive to other environmental effects (eg.: external heat, light)

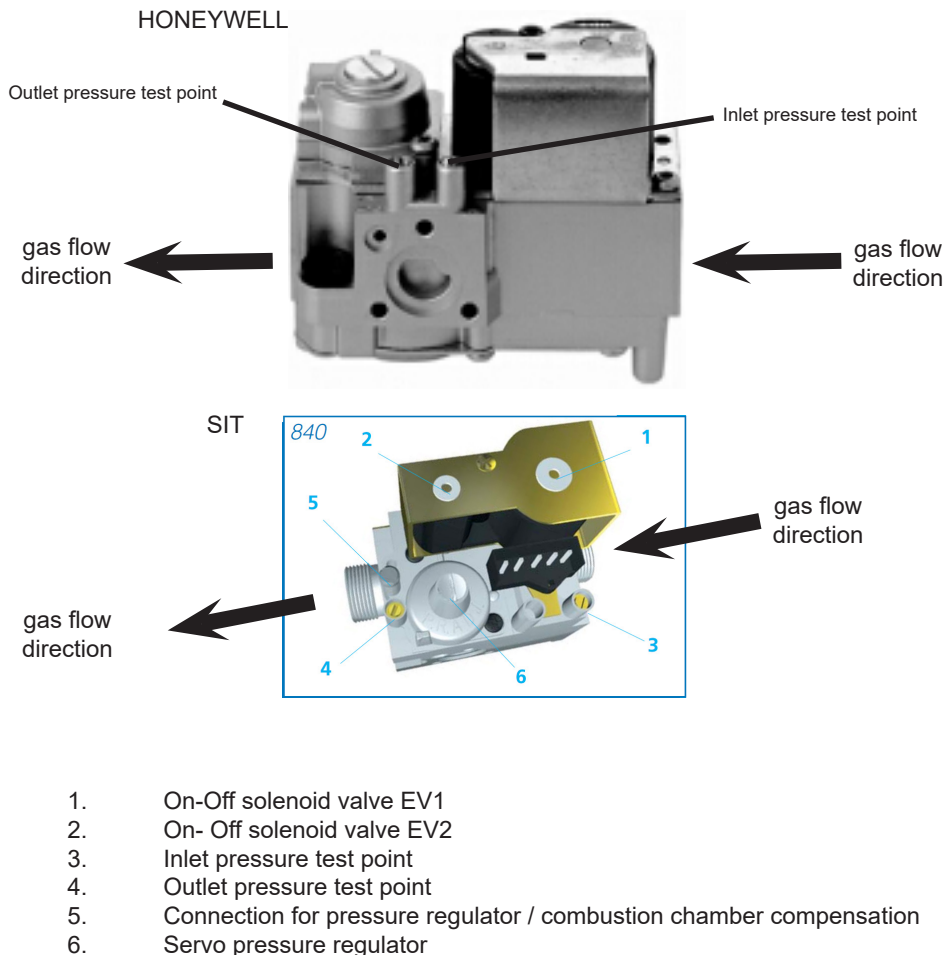

12.picture: Input and output gas pressure checking connections in case of SIT or Honeywell solenoid valve



ATTENTION! At the first start need to check the outlet gas pressure!

Value of the outlet gas pressure:

Automatic appliances

- Natural gas and S-gas: 16 mbar
- Propane gas and PB gas: 45 mbar

Manual appliances:

- Natural gas and S-gas: 20 mbar
- Propane gas and PB gas: 50 mbar

In some countries in a case of a 37 mbar gas line system pressure we must set a 32 mbar nozzle pressure.

General informations

The flame control is a self controlling device and it controls only the Burner which it will intervenes and it is not sensitive against other environmental effects such as external heat, light, and so on...

7. MAINTENANCE

MAINTENANCE TYPES

Besides supervision and clearing of ceramic plates and reflector (see: Maintenance supervisions by the customer), GH infrared heater does not need a separate maintenance, but to keep its SAFETY OPERATION and LONG LIFETIME, it is recommended to check appliance once a year by a qualified technician.

MAINTENANCE SUPERVISIONS BY THE CUSTOMER

- Check the statement of reflectors and clean them if it is necessary. Clean them by a soft cloth or a diluted detergent.
- Check, if catalytic grid made of heat-resistant steel placed in front of ceramic plates touches ceramic plates or not. In case it touches it at some places, then drag it away from ceramics by a thin bent steel wire.
- Check ceramic plates. Blow them sometimes through by compressed air when it is switched off and cool enough.
- Check, if ceramic plates are broken or not by a survey. There is a bright line during glowing position at a broken appliance, which line indicates the place of breaking.
- Check mountings screw fastenings at fixing frame by survey.

It is advisable to make a maintenance contract for the proper maintenance or call our qualified service department for regular maintenance.

CHECK AT THE BEGINNING OF SEASON

Test system start-up and check the regular operation of device.

Checking the regular operation:

- At automatic appliance:** Switch on device, let it operate some minutes, then push the gas control knob to the OFF position. Burner stops operating. Wait for 6-8 minutes then turn the gas control knob to the ON position and appliance will start to operate after the pre-purge time again.
- At manually ignited appliance (GH-7 G20/K, GH-7 G30/K, GH-7 G31/K):** When pushing thermo-valve down gas flow starts across the nozzle then the Venturi and finally reaches mixing nozzle. Matches, etc. could light gas coming out of bores of ceramic plate. After gas catches fire push button must be pushed for approx. 30 s. After all, thermo-element should ensure keeping the valve in opened position.



ATTENTION! In case operational circumstances of appliance (atmosphere is contaminated with corrosive substances, dirt etc.) need it, then supervision and cleaning may have done more often! The main reason of this that the settled dirt on the radiant tubes can damage the efficiency of it and load the tubes hereby loading the suspensions of it significantly!

MAINTENANCE SUPERVISIONS BY A QUALIFIED SERVICE DEPARTMENT

All kinds of interventions for which dismantling of device is necessary:

- Supervision of nozzle pressure (at the secondary outlet of solenoid valve)
- Supervision of electrical connection
- Supervision of ignition module and spark interval
- Supervision of thermo-element and thermo-valve at manually ignited appliance.

GAS CHANGE

In case you would like to operate your appliance by another type of gas (for example by Propane or PB instead of Natural gas), then turn to the local authorised representative or a qualified service department.



In case you would like to operate your appliance by another type of gas (for example by Natural Gas or Propane instead of butane gas), then turn to the local authorised representative or a qualified service department.



ATTENTION! This operation can be made just the qualified service department or specialist, who is entrusted by the manufacturer!



**ATTENTION! If an intervention needs the disassembling of burner turn to a qualified service department, which is authorized by the representative!
Disregard of these instructions can result in death, injury or property damage!**

8. TROUBLESHOOTING

SYMPTOMS		POSSIBLE CAUSES	CORRECTIVE ACTIONS
IGNITION AND FLAME SENSING SYSTEM	CERAMIC SURFACE		
There is no spark between electrodes of the igniter		<ul style="list-style-type: none"> • The electrodes of igniter is polluted • Electrical connection between igniter and automation is broken • Spark interval is too large • Automatic control went wrong • The ceramic on ignition electrode is broken 	<ul style="list-style-type: none"> • Clean electrodes • Check electrical connection between ignition module and electronic • Check spark interval • Please change the ignition and ionization electrode • Replace automatic control
Ignition cycle is finished normally	Appliance does not operate after the first ignition cycle	<ul style="list-style-type: none"> • The gas supply valve is turned off • Air is not removed sufficiently from gas pipe • Nozzle pressure is not suitable 	<ul style="list-style-type: none"> • Turn on the gas supply valve • Remove the air from the pipe • Check the input and output pressure on the solenoid valve
Ignition cycle is finished normally	Appliance does not operate after the first ignition cycle	<ul style="list-style-type: none"> • Solenoid valve went wrong • Uncertain connection between ignition module and automatic control • Nozzle pressure is not suitable 	<ul style="list-style-type: none"> • Replace the solenoid valve • Replace the differential switch • Check the input and output pressure on the solenoid valve
	The ceramic burner ignites but stops soon	<ul style="list-style-type: none"> • The phase and null are replaced • Nozzle pressure is not suitable • The ceramic plates are contaminated • The Ignition electrode is touching the catalytic grid 	<ul style="list-style-type: none"> • Check the wires connection points • Check the input and output pressure on the solenoid valve • Please clean all the ceramic plates. (compressed air is required) • Please remove, and keep some distance from the catalytic grid (at least 2 mm)
	The unit is working, but the efficiency, as also the temperature of the ceramic plates are lower as the normal operation condition	<ul style="list-style-type: none"> • Nozzle pressure is not suitable • The ceramic plates are contaminated 	<ul style="list-style-type: none"> • Please clean all the ceramic plates. (compressed air is required) • Check the input and output pressure on the solenoid valve
	Appliance operates but the combustion is uneven and noisier than it should be	<ul style="list-style-type: none"> • Nozzle pressure is not suitable 	<ul style="list-style-type: none"> • Check the input and output pressure on the solenoid valve

9. ENCLOSURE

ENCLOSURE 1.: TYPE AND TECHNICAL DATA OF INFRARED HEATER

Type	Design	Useful Capacity (kW)	Connecting gas pressure	
			NG/S-gas (mbar)	Pr/PB (mbar)
GH-7/K	K	6	20 v. 25	50
GH-7	A	7	20 v. 25	50
GH-11	A	11*	20 v. 25	50
GH-18	A	18,2*	20 v. 25	50
GH-23	B	22**	20 v. 25	50
GH-36	B	36,4	20 v. 25	50

* At the GH-11 appliances the net heat input is 10 kW, with propane gas.

** At the GH-23 appliances the net heat input is 20 kW, with propane gas.

"K" = manual ignition with one piece of mixing house

"A" = automatic ignition with one piece of mixing house

"B" = automatic ignition with two pieces of mixing houses

ENCLOSURE 2.: GAS CONSUMPTION OF GH HEATERS

Type	Input power (kW)	Gas consumption		
		m ³ /h	(kg/h)	
			Natural gas	PB
GH-7/K	6	0,63	0,50	0,50
GH-7	7	0,74	0,58	0,58
GH-11	22	1,16	0,92	0,91
GH-18	18,2	1,91	1,52	1,50
GH-23	22	2,31	1,84	1,82
GH-36	36,4	3,82	3,04	3,01

ENCLOSURE 3.: TARGET COUNTRIES/GAS CATEGORIES

TARGET COUNTRIES	APPLIANCE CATEGORY	GAS PRESSURE OF CONNECTION (MBAR)		EXHAUST POSSIBILITIES
		2. FAMILY	3. FAMILY	
AT	I12H3B/P	20	50	A ₁
BE	I12E+3+, I3P	20/25	30/37, 50	
BY	I12H3B/P	20	30, 50	
CY	I12H3+, I3B/P	20	30/37, 50	
CZ	I12H3P	20	37	
DK	I12H3B/P	20	30	
GB	I12H3+, I12H3P	20	37/50, 37, 50	
EE	I12H3B/P	20	30	
FI	I12H3B/P	20	30	
FR	I12E+3+, I12H3P	20/25	30/37	
GR	I12H3+, I12H3P	20	30/37, 37	
NL	I3B/P, I3P, I12L3B/P	25	30, 50	
IE	I12H3+, I12H3P	20	30/37, 37	
PL	I12E3P, I12E3B/P	20	37, 30	
LV	I12H3B/P	20	30	
LT	I12H3B/P	20	30	
LU	I2E	20		
HU	I12HS3B/P	25	30, 50	
DE	I12ELL3B/P, I12ELL3P	20	50	
NO	I12H3B/P	20	30	
IT	I12H3+	20	30/37	
PT	I12H3+, I12H3P	20	30/37, 37	
RO	I12H3B/P	20	30	
ES	I12H3+, I12H3P	20	30/37, 37	
CH	H2H3B/P, I12H3+, I12H3P	20	50, 30/37, 37	
SE	I12H3B/P	20	30	
SK	I12H3B/P, I12H3P	20	30, 37, 50	
SI	I12H3B/P, I12H3P	20	30,37	
TR	I2H, I3P, I3B/P	20	37	
UA, RU, BA, BG, MD, RS, HR	I12H3B/P	20	30,50	
IS	I3B/P		30	

GUARANTEE AND SERVICES

PRESERVE THIS WARRANTY

Type: _____ Serial no.: _____ Date of purchasing: _____

LIMITED GUARANTEE *

The manufacturer guarantee the customer that the product and its parts are free from material and production failures. During normal use the warranty is 2 years. This warranty concerns the first retail customer.

The guarantee concerns the costs of laboratory investigations and the parts, which are needed for proper operation. The delivery and unforeseeable costs belong also to the mending costs and do not contain compensation costs.

Guarantee mending can only be realized by authorized retailer or service centre.

The guarantee does not concern the following failures, which are caused by: improper using, damaging, neglect, accident, lack of maintenance, normal attrition, transformation, modification and operation influenceable factor, contaminated fuel, installation of non-suitable part and mending which is done by not authorized retailer or service station.

The regular maintenance is the owner's responsibility.

The manufacturer does not assume the responsibility in case of accidentally happened or directly caused mistake respectively improper using.

***We reserve the right to change of this specification without extra notification. The guarantee can be applied in accordance with above defined.
Additional guarantee is not accepted.**

Guarantee servicing

If your appliance needs guarantee service in that case it can be requested at nearest authorized service station giving in the appliance for repairs.

Mending services

Take the appliance to the nearest authorized service station. If the device is not under guarantee the service cost will be invoiced to the customer at defined price. The service centres are independent from one another and may have different owners. We reserve the right to change of this specification without extra notification. If you would like to contact us the type and serial number of device always be at hand. In case of other needed information write to distributor.

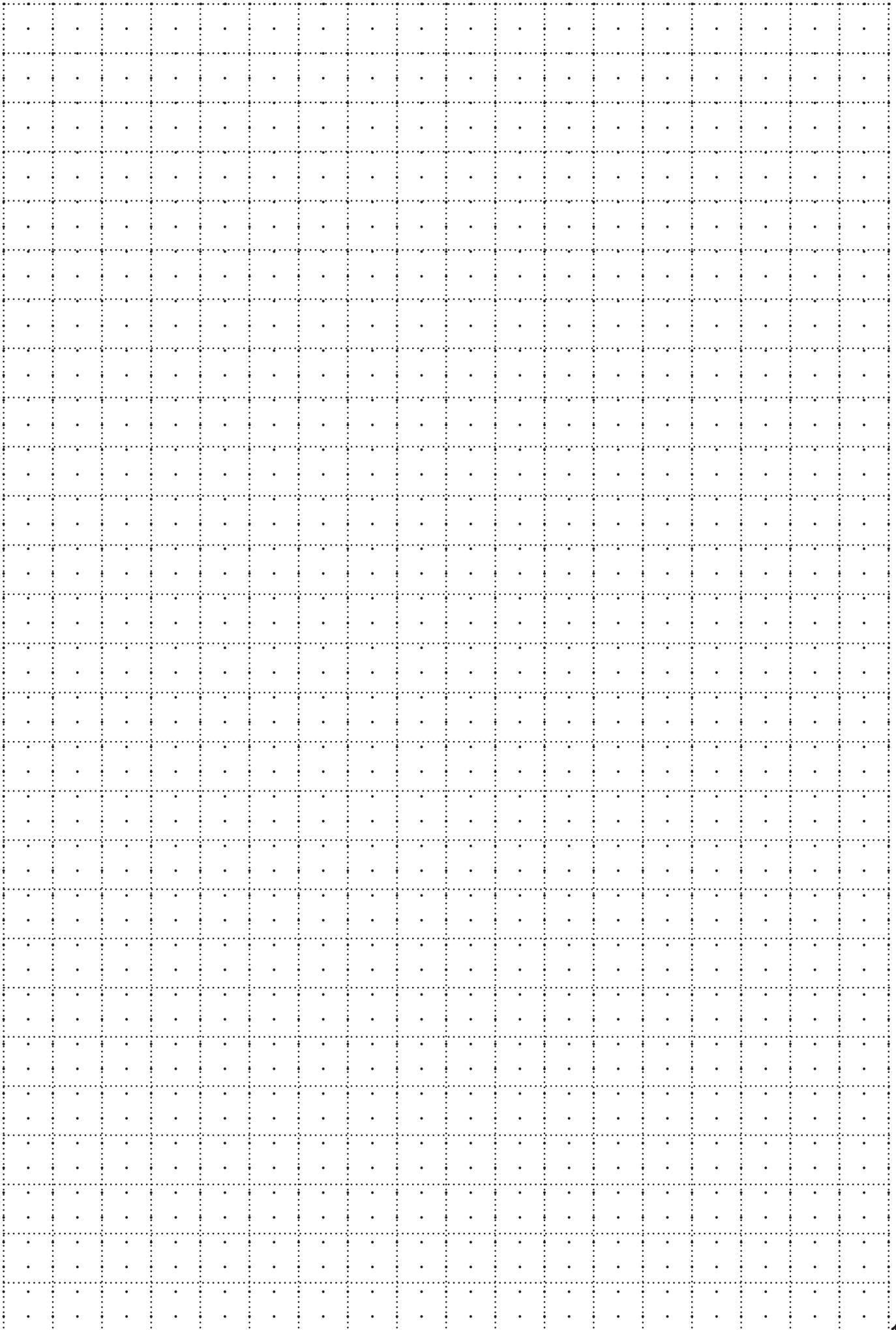



PAKOLE

www.pakole.com

PAKOLE TRADE Ipari és Kereskedelmi Kft.

H-8000 Székesfehérvár, Börgöndi út 8-10.

www.pakole.com

mail@pakole.hu

Tel.: +36 22 316 484

Fax.: +36 22 316 074