



PAKOLE

USER'S MANUAL

(For users)

AIR HEATERS WITH PROPANE OR NATURAL GAS

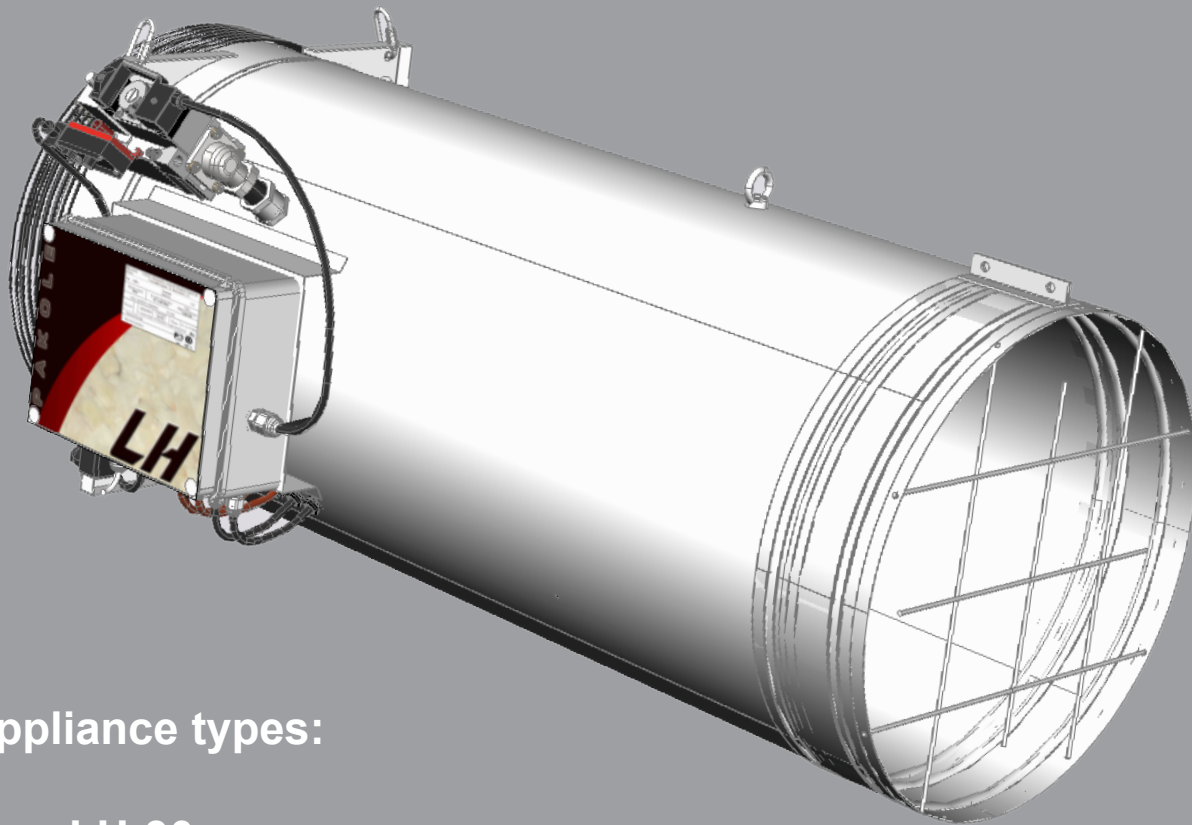

Appliance types:

LH-30

LH-40

LH-50

LH-60

LH-70

LH-80

LH_009_030_011_240807_V004_EN

www.pakole.com

EN

Table of Contents

SAFETY INFORMATION	3
GENERAL INSTRUCTIONS.....	4
Data board	4
Installer's responsibilities	4
Corrosive materials	5
Standards and laws	5
Safety signs	5
Safe usage.....	5
TRANSPORT, UNPACKING, HANDLING	6
OPERATING PRINCIPLE	7
The gas supply system	7
The air supply system	7
The ignition system	7
Safety monitoring and intervention systems	7
INSTALLING THE DEVICE	8
LH air heater	8
Gas connection	9
Installation of the device	10
LH air heater dimensions per type	11
Suspension	11
Electrical connection	12
CONTROLLING THE DEVICE.....	13
OPERATION.....	13
Starting the device	13
Error detection (RESET)	14
Switching off the equipment.....	14
MALFUNCTIONS AND TROUBLESHOOTING	15
MAINTENANCE	16
Maintenance operations.....	16
Maintenance operations to be carried out only by a professional service	17
Gas exchange	17
TECHNICAL PARAMETERS.....	18
ANNEXES.....	18
Annex 1: LH air heater performance data and gas consumption.....	18
Annex 2: Air delivered by LH air heater	18
Annex 3: Number of burners for LH air heater.....	18
GUARANTEE AND SERVICES	19

1. SAFETY INFORMATION



ATTENTION! Read and understand this Installation and Maintenance Instruction before using the equipment! Keep this Installation and Maintenance Guide to answer any questions you may have later!

GENERAL SAFETY WARNINGS!



Failure to follow the warnings and instructions in the enclosed Installation and Maintenance Manual may result in serious injury or property damage.

The appliance may only be used by persons who have understood and followed the instructions in the Installation and Maintenance Manual! If you need help or information about the heater, such as installation instructions, contact the manufacturer.

This appliance is not intended for use by persons with reduced physical, sensory or mental capabilities, or lack of experience and knowledge, including children. Children should be supervised to ensure that they do not play with the appliance.



WARNING! Fire, burn, inhalation and explosion hazard! Keep combustible materials such as building blocks, paper or cardboard boards at a safe distance from the heater according to the instructions! Never use an open system appliance in a room where flammable volatile substances or the following products are present or may enter the appliance: petrol, solvents, thinners, granular dust or unknown chemicals!



ATTENTION! The appliance must not be used at home!



WARNING!

For your own safety, if you smell gas, do the following:

Open the windows.

Do not try to turn on the lights or turn on any appliances.

Do not use any electrical switches.

Do not use any telephone in the building.

Leave the building.

Call your local gas company after leaving the building. Follow the gas company's on-call instructions.

If you cannot reach the gas company, call the fire department.

The LH appliances have been developed and certified in compliance with EN 17082:2019 standard and qualified for heating of industrial rooms! The function of these heater appliances to ensure heating of appointed workplace temporarily or continuously! In case of proper using the appliance guarantees safety and energy-saving operation! The combustion products issued during combustion process leave through the flue system into the open air. In case of further possible questions regarding the applicability please turn to the local Fire Protection Office!

Other standards can give you directions in terms of proper using of natural and propane gas as follows: leading/piping, storing etc.! Concerning the detailed content of these standards the local Bureau of Standards can help.

Carbon- monoxide poisoning: The initial symptoms of carbon-monoxide poisoning are similar to influenza namely headache, dizziness and/or nausea! If these symptoms are observed in that case the appliance probably does not work satisfactorily! First of all go fresh air, ventilate the rooms and have the appliance investigated!

Propane-gas: The propane-gas odourless! Mercaptan-derivative as scented component is mixed into the gas to be able to observe the possible escape! In spite of the typical smell is not felt the propane gas can be present in the environmental air in case of escaping!

2. GENERAL INSTRUCTIONS

- During the installation be always circumspect! Follow the valid instructions and recommendations!
- The appliance can be operated by specified voltage and frequency marked on its data board! The electrical connections and groundings are prepared as per EN 60335 standard!
- Electrical grounding specification: present appliance is equipped with three points grounding connection in the interests of your protection!
- When used in confined spaces, adequate ventilation air must be provided.
- Use the equipment only in a well-ventilated room. The required combustion and ventilation air volume can be determined according to Annex 1.
- The appliance must not be used in the open air!
- Keep the equipment away from the following strong impacts: wind.
- The application of device is **STRICTLY PROHIBITED** in such rooms, which are used for sleep or continuous stay!
- Keep away the flammable materials from the appliance and its near environment as follows: fuels, thinner or other flammable fluids and vapours!
- Before starting of appliance in every case check it in order to detect the possible damages! Never use damaged equipment!
- In case of propane-gas operation never install the device in basement or from that lower being rooms! The propane-gas is heavier specific gravity than the air for this reason in case of possible escaping it will spread towards the lower located rooms!
- Only use that kind of flexible gas pipe and pressure regulator, which is offered for the appliance by the manufacturer!
- Before every starting of heater appliance check the condition of connecting gas hose and if it is particularly worn or damaged in that case exchange it for a new one specified by manufacturer!
- Preserve the equipment in genuine condition, do not leave it to grow old!
- Do not use seriously aged equipment any longer!
- Hang the appliance on a stable surface that will maintain its stability during operation, even if the appliance heats up.
- Keep children away from the equipment.
- If the appliance is put out of use in every case it must be cut off the current and gas!
- Never block the air supply and exhaust pipes!
- Never service/mend such devices, which are hot and during operation or electrical charged!
- Never mount such air duct unit on front or back side of device!
- Use exclusively genuine-approved by manufacturer-spare parts, do not install similar quality spare parts for substitution! These kind of substitute parts can cause serious damages concerning the operation of appliance!
- **In all cases, install a pressure relief device recommended and approved by the manufacturer, with a minimum pressure of not less than 25 mbar and a maximum pressure of not more than 60 mbar.**

DATA BOARD

The device is equipped with a data board, which is located on the outside of the device. The data board contains information on the type of appliance, the type of gas and the electrical connection. For example:



Manufacturer PAKOLE Trade Kft. 8000 Székesfehérvár, Börgöndi út 8-10.		Type LH-70		 2806 20
Electrical protection: IP44		Nominal input: 70 kW Pconnecting max.: 60 mbar		
Electrical connection: AC 230V 50Hz		Pconnecting nom.: 37 mbar		 2806 20
Max. current entry: 2,1 A		Airflow: 3600 m³/h		
Electrical power: 483 W		Category: I2H, I3P, I12H3P		PIN: 1008 CQ 2800 <small>Date/place of production</small>
Series number: 37-249-2716		Targeted country: ES Gas type: PB		

Figure 1: Data board

INSTALLER'S RESPONSIBILITIES

- Gas and electrical connections are made in accordance with the regulations (it is recommended to contact the local building inspectorate or the Fire Brigade),
- The installation of the apparatus in accordance with the layout described in this instruction manual,
- Installation according to fire safety regulations,
- The provision of materials (not included in the appliance) necessary for installation,
- The design of ventilation, connections and ducts,
- To carry out the servicing, to provide the Owner with the instructions for use supplied with the equipment
- Ensuring sufficient air circulation around the unit,
- Determining or providing the prescribed amount of air for combustion.

CORROSIVE MATERIALS

 **ATTENTION! Do not use the device in a place where there may be corrosive substances in the air!**

The manufacturer accepts no liability for damage to the device if it has not been installed as described above. This responsibility is entirely the responsibility of the person performing the design. To avoid such possibilities, if you are not sure about the fit to the building or activity, ask our staff for help.

The owner(s) and the person(s) coordinating the installation must identify any gaseous or solid substances present in the space to be heated which may be present in the building and which could significantly affect the operation or service life of the appliance (combustible materials, corrosive substances, halogenated hydrocarbons, etc.) and then,

STANDARDS AND LAWS

All devices must be installed in accordance with laws and standards. These laws refer to electrical wiring (there are special regulations for parking garages, aircraft hangars, etc.).

SAFETY SIGNS

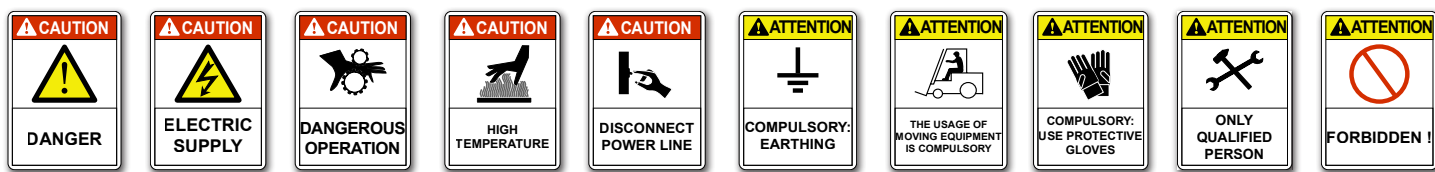





SAFE USAGE

 **DANGER**  **ONLY QUALIFIED PERSON** 





Observe the following relevant rules during installation, adjustment and service:

- In all cases, the standards, regulations and country-specific regulations of the country of installation must be strictly observed during installation.
- Installation and maintenance of the device may only be performed by a qualified person.





A **qualified person** is any person who has significant technical experience in the field of heating and ventilation installation and / or has a professional examination in the field, as well as has participated in the mandatory annual training organized by manufacturer. Call your nearest reseller for information.

 **DANGER**  **ELECTRIC SUPPLY**  **COMPULSORY: EARTHING**  **ONLY QUALIFIED PERSON**





- Depending on the design, install the electrical wiring system.
- Before starting the appliance, always make sure that the appliance and its electrical components are properly earthed.

 **DANGER**  **ONLY QUALIFIED PERSON**  **COMPULSORY: USE PROTECTIVE GLOVES** 

- If you disassemble the equipment, use protective gloves!
- Be careful of sharp corners!
- Watch out for roof pitches on externally installed appliances!
- Always keep the intake vent clean!

 **DANGER**  **DANGEROUS OPERATION**  **FORBIDDEN !** 

- Before cleaning or maintenance operations that can be performed by the customer (see chapter 8), after disconnecting the power supply, make sure that the fan has stopped rotating automatically. (Do not stop the still running fan by hand or other means!)
- The fan can reach 1000 RPM so don't put anything in the way of the blades.

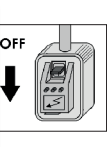
 **DANGER**  **ELECTRIC SUPPLY**  **DISCONNECT POWER LINE**  **COMPULSORY: EARTHING** 

CHECK EARTHING !!

- We recommend that you install a separate, easily accessible disconnect switch near the machine to easily unplug the machine. Always unplug the appliance before cleaning or servicing.
- Before opening the appliance, make sure that all its components have been electrically disconnected from the mains. Take special care to make sure that the fan is stationary and cannot start during the installation process.

 **DANGER**

- This equipment is designed for heating - cooling tasks. Any other use is not permitted and may be dangerous.
- When used in the vicinity of persons with reduced mobility, the device must be placed at a suitable, inaccessible distance from these persons.
- Improper installation can cause environmental or personal damage. The manufacturer is not responsible for damage resulting from such faulty installation.
- Furthermore, the manufacturer cannot be held responsible for damage resulting from incorrect, improper use.



- Never use the appliance in connection with another appliance.
- Never leave tools or accessories inside or on top of the appliance.
- Ensure that all test doors are properly closed.
- Do not place the device in a flammable environment.



- In the event of a malfunction, do not attempt to service the device, call your distributor immediately.
- If you want to leave the unit turned off for an extended period of time, make sure that it cannot harm anything or anyone under any circumstances.

3. TRANSPORT, UNPACKING, HANDLING

- The transport must be carried out as follows :
 - Packages must be properly secured in the hold.
 - Packages should be transported protected from the weather, preferably in a closed hold.
- The device is equipped with special transport packaging suitable for transport, which must be kept in good condition until the date of delivery to the installation site.
- Check that the device contains all the parts and accessories included in the order.
- Check that the appliance is not damaged and that its type corresponds to the type ordered. All devices are shipped from the factory after testing, so if you notice any damage, notify your carrier immediately.

Transporting, unpacking and packing the device is a process that must be carried out with special care to avoid possible damage. Do not attempt to use the components of the device as a handle. When lifting, make sure that the centre of gravity of the package is at the centre of the lifting fork of the lifting machine.



The device is delivered in a corrugated cardboard box on a one-way pallet. The process of unpacking the device:

- remove the appliance, tubes and assembly materials from the paper boxes,
- **do not remove the protective caps until the gas is connected to the appliance,**
- check the condition of the appliance, pipes and fittings,
- in the event of damage to the equipment, immediately notify the retailer from whom you purchased the equipment.

Inside the device, you will find the Installation and Maintenance Manual, the User's Manual, the Warranty Certificate and the Installation and Operation Manual.

- **After unpacking the appliance, the second step is to remove the airflow switch and the fan mounting rod (option).**

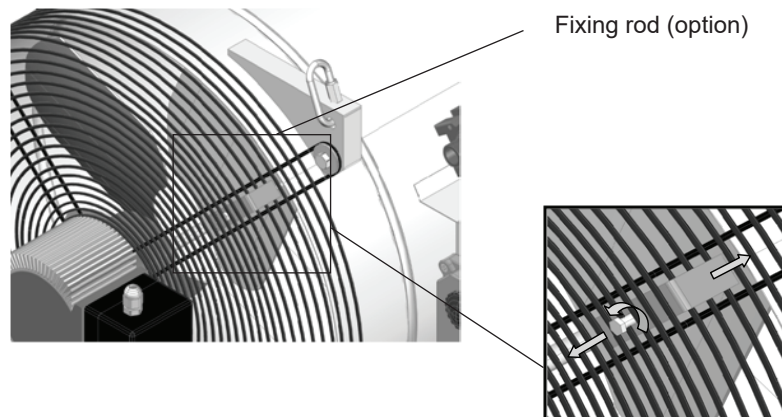

Figure 2: Removing the fixing rod

The fixing rod can be removed by loosening the screw at the end of the rod and pulling it out of the hole. After pulling out the rod, also remove the metal plate that positions the rod.

4. OPERATING PRINCIPLE

THE GAS SUPPLY SYSTEM

For safe operation of the appliance, the gas network must have a minimum pressure of 25 mbar and the network pressure must not exceed 60 mbar.

After connecting the gas connection kit to the gas mains and opening the ball valve, the gas flows through the gas filter and the double-closing combined gas solenoid valve through the nozzle bores into the firebox.

THE AIR SUPPLY SYSTEM

The motor turns the fan blades, which create the right airflow inside the appliance. The resulting air flow carries with the heat generated by the combustion of the gas-air mixture and the combustion products.

THE IGNITION SYSTEM

Depending on the need for heating, the control electronics sends an electrical high-voltage signal to the spark plug when heating is required, causing it to spark and ignite the gas-air mixture.

SAFETY MONITORING AND INTERVENTION SYSTEMS

The device is equipped with a three-point safety system for your (the user's) safety.

- Ionisation flame detector
- airflow detector
- safety temperature limiter

In certain countries, Ukraine, Russia, etc., depending on the regulations, may require the use of a four-point safety system, which in addition to the above-mentioned monitoring and intervention systems, also requires the use of a gas pressure sensor.

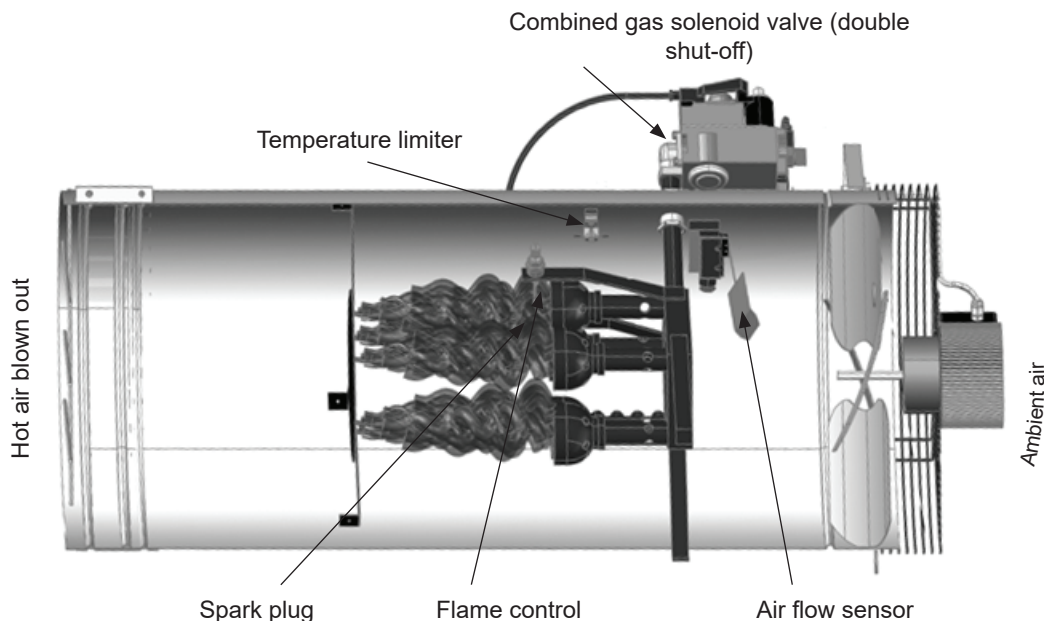

Figure 3: Cross-sectional image + operating principle

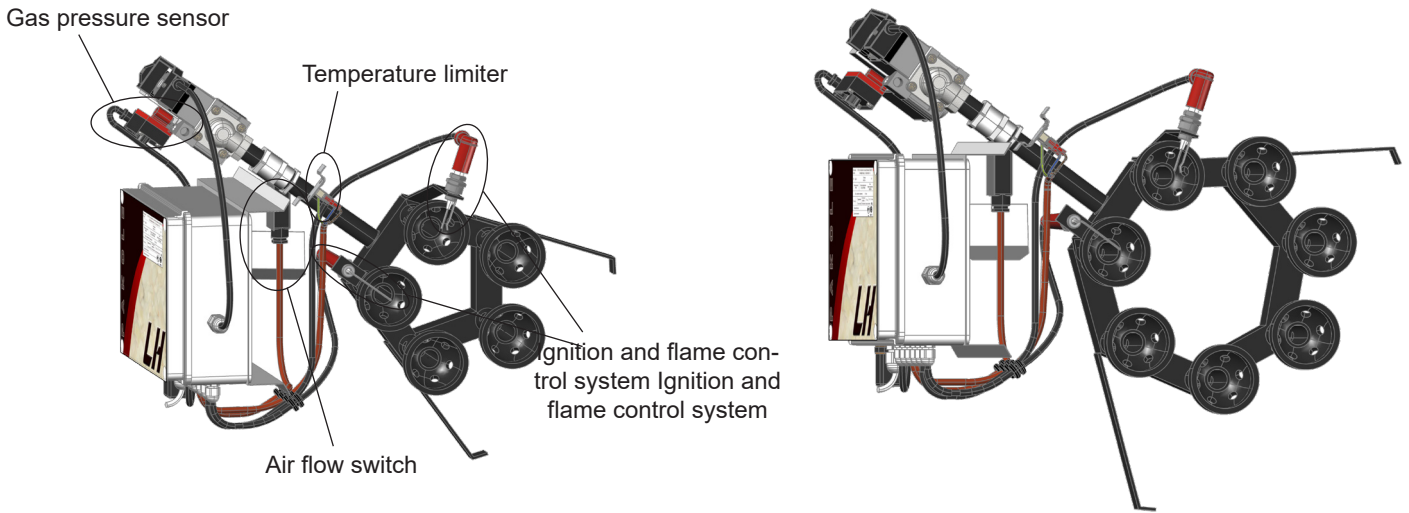

Figure 4: Burner head + safety units (for small and large burner groups)

5. INSTALLING THE DEVICE

LH AIR HEATER

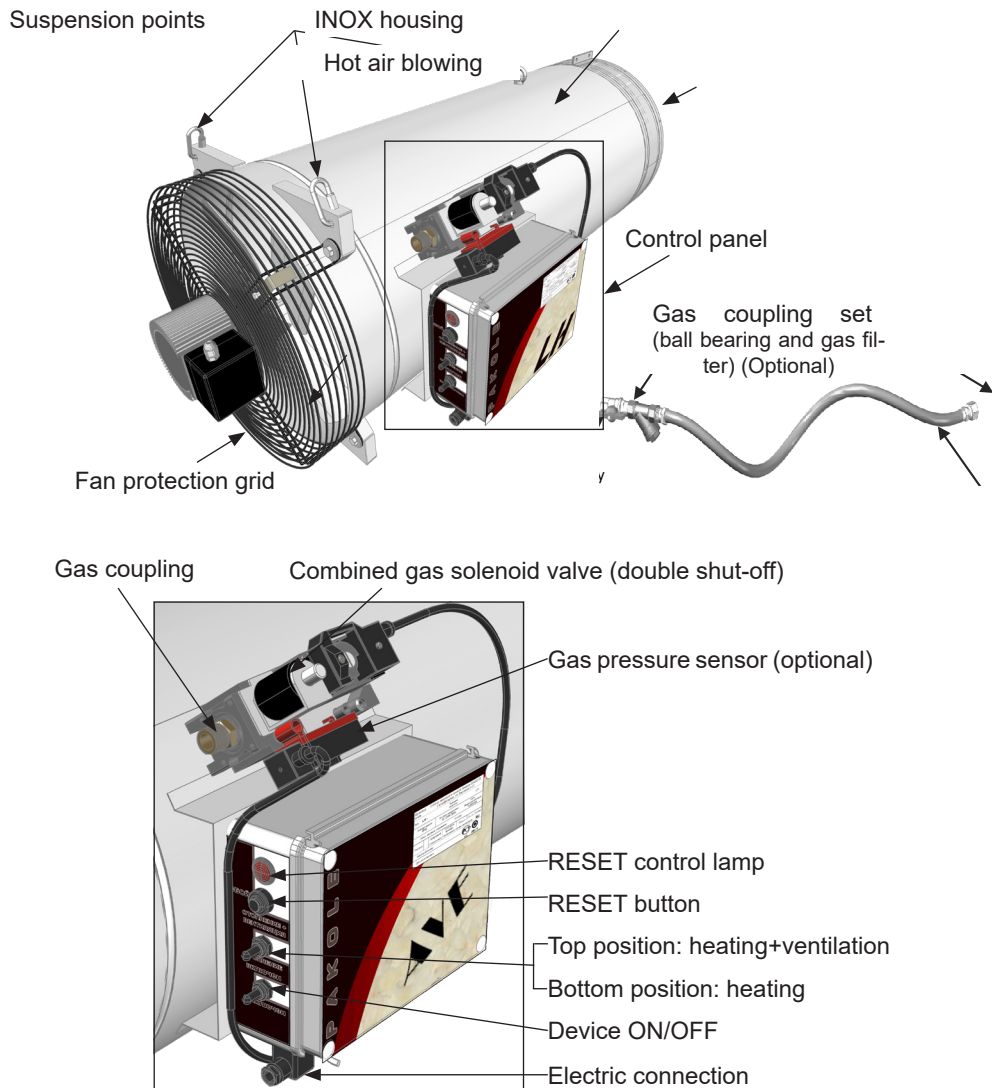

Figure 5: Main structural elements of the LH air heater

GAS CONNECTION

WARNING! The appliance may only be used with the type of gas indicated on the data plate of the appliance!

WARNING: Air heaters of type LH... may only be used with the type of gas indicated on the data plate of the appliance.
Nominal connected gas pressure for natural gas: 25 mbar
Nominal value of the connected gas pressure for propane: 50 mbar
Maximum connected gas pressure: 60 mbar

WARNING! If the pressure of the gas supply is higher than 60 mbar, the use of a pressure regulator is essential, because the maximum allowable pressure of the double-closing solenoid valve is $P_{max} = 60$ mbar.

The pressure regulators can be installed individually in front of each appliance or 1 centrally on the main gas line.

Individual, that means, if a pressure regulator is installed directly in front of each appliance, only in front of the pressure regulator, if a central pressure regulator is used, the installation of a gas filter in front of the pressure regulator and each appliance is mandatory! The installation of a gas filter is mandatory in order to avoid blockage or clogging of the pressure regulator and the gas solenoid valve of the appliance, which can be caused by possible deposits in the pipe (even if the gas line is blown out). The gas mains must be connected from above or from the side, because a connection from below serves as a collection point for dirt, which affects the correct functioning of the appliance.

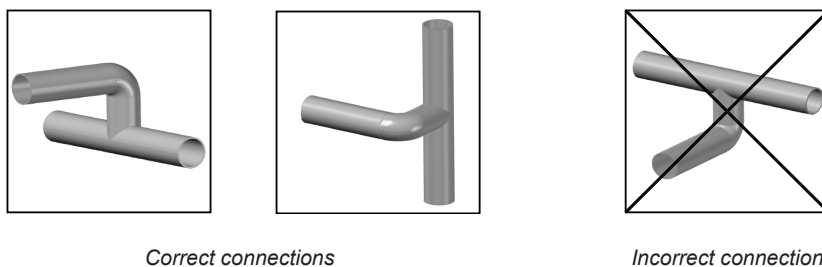

Figure 6: Connection to the main pipeline

When designing the connection, the thermal expansion of the appliance must be taken into account, so the gas connection should be made with a flexible hose. Use a flexible hose when designing the connection to allow 100 mm of free expansion.

WARNING! Install the hose without twisting!

The pressure regulator can be installed before each appliance or centrally namely one piece into the gas-supply pipe. In case of unique solution - namely there is pressure regulator before each appliance – before every pressure regulator, in case of centrally mounted pressure regulator before pressure regulator and each appliance **MUST BE INSTALLED GAS FILTER** to be able to avoid the blocking of appliance's gas magnetic valves, which can be caused by possible contamination settled in the supply pipes (Despite blowing out of pipes it can be present).



Figure 7: Gas connection kit supplied by PAKOLE TRADE Ltd.

Operations to be performed:

- Cleaning of gas pipelines

Before the appliance is connected to the gas mains, it is important to clean the gas mains completely and thoroughly.

- Gas tightness check

After connecting the appliance, make sure the gas connection pipe is tight. This operation must be carried out after each disassembly and assembly.

INSTALLATION OF THE DEVICE



The installation must comply with the regulations and rules in force in the area and the installation must be carried out in accordance with these regulations and rules when installing the appliance. The installer shall carry out the mandatory gas tightness test on the gas appliance inlet pipe. Before installation, the local conditions, gas type and pressure must be checked to ensure that the appliance is set up in accordance with these.

SAFETY AND FIRE DISTANCES FROM COMBUSTIBLE MATERIALS:

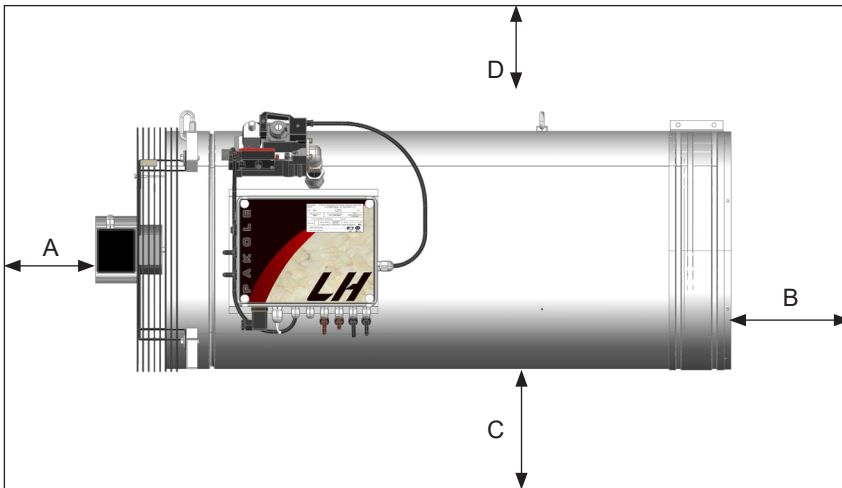

Capacity (kW)	Safety distances (mm)			
	A	B	C	D
30 kW	300	1200	500	500
40 kW	300	1350	500	500
50 kW	450	1500	500	500
70 kW	450	1650	500	500
80 kW	450	1800	500	500

Table 1: Safety distances from device power performance

Figure 8: Safety distances

LH AIR HEATER DIMENSIONS PER TYPE

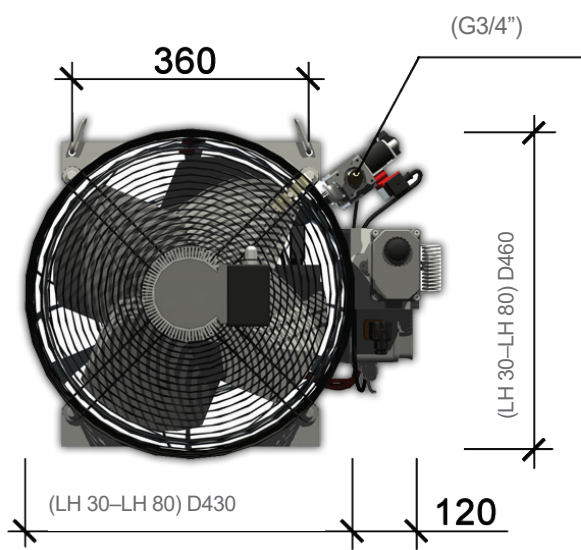
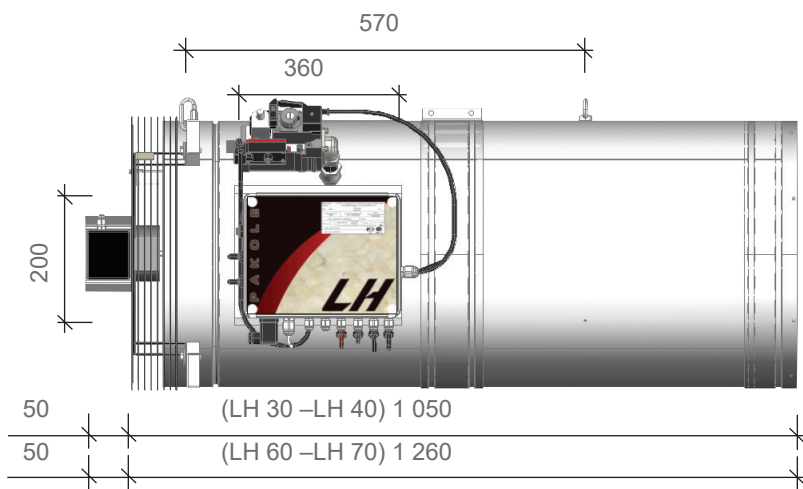

Figure 9: Air heater dimensions per type

SUSPENSION

Once the exact location of the appliances and the brackets have been determined, care must be taken to ensure that the min. 300 mm long hangers (e.g. chain). Suspension of the hangers may be under ceiling or roof structure, under support bars or scaffolding, between columns or next to a wall, on a bracket, etc. The equipment is suspended by means of fixing holes at each end of the equipment and by means of a fixing eye at the front of the equipment. The design of the suspensions shall also take into account the inclination of the apparatus. A horizontal positioning is recommended in all cases, with a maximum deviation of +5° or -5°.

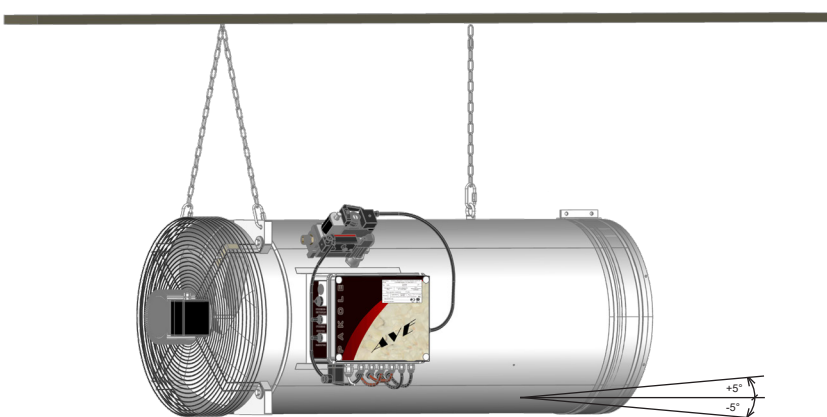

Figure 10: Maximum inclination of the device

ELECTRICAL CONNECTION

The axial fan for combustion air and air flow, as well as the electronics, require 230V/50Hz /2A mains voltage.

**WARNING:**

- The equipment must be connected to the mains supply by means of a safety plug on the control unit (box).
- A circuit breaker must be installed into the electrical network front of the appliance.
- Ways of connecting to the network:
- Grounded plug-in forks or fixed wiring can be done in phases.
- The EPH point of the equipment must be connected to the EPH network of the building!
- Power supply cable: 3-pinned MT cable.
- Maximum current consumption of the device: 1.5 A.
- The device is phase sensitive, so always connect as indicated.
- Fuse: 10 A small circuit breaker.

7.12.5 The instructions for Y-connected appliances shall include the essentials of:

If the mains lead is damaged, replacement should be carried out only by the manufacturer, its service agent or other suitably qualified person to avoid any risk.

25.15 Appliances fitted with a mains connection lead and appliances intended for permanent connection to a fixed wiring network which are connected to the network by a flexible lead shall have a lead strain relief device.

An electrical wiring diagram with BRAHMA CM 31 electronics is given in Annex 7.

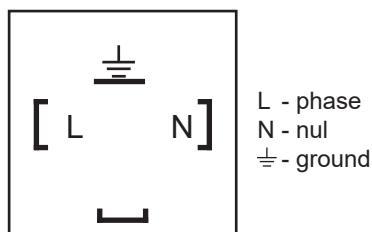

Figure 11: Wiring diagram for connection to the electricity network

6. CONTROLLING THE DEVICE

The air heater type LH-... can be controlled by a central or individual temperature controller mounted on the heater. If there is a central temperature control in the room to be heated, an individual temperature control is not necessary and is therefore not fitted at the factory.

In case of individual control, the temperature control is located on the side panel of the control panel, in front of the airflow fan. Control range: 0-40°C. The temperature is automatically controlled by switching the appliances on and off according to the room air temperature and the temperature values preset on the temperature controller. The equipment can be fitted with an external temperature controller, the correct connection points for which are given in Annexes 7 to 8.

The equipment can be operated in three ways:

- VENTILATION ONLY
- CONTINUOUS VENTILATION + HEATING
- HEATING ONLY

VENTILATION ONLY

In this case, the room does not require heating, but a fan is needed either for air exchange or to move the air in the room. Turn the lower on/off switch of the two switches on the side of the control box to the 'on' position. The switch above it, the 'heating - ventilation' and 'heating' switches located above the control box are set to 'heating - ventilation'. Set the thermostat for temperature adjustment to minimum. In this position, the appliance will only ventilate.

CONTINUOUS VENTILATION + HEATING

The position of the switch corresponds to the „ventilation only” mode, except that the thermostat must be set to the desired temperature. If the room temperature drops below the set value, heating is started, if no heating is needed because the thermostat has reached the set value, only ventilation is started.

HEATING ONLY

Turn the on/off switch on the control box to the „on” position and the two-position switch above it to the „heating” position. In this case, the appliance will heat the room to the temperature set by the thermostat and when the set temperature is reached, the heating will be switched off and the ventilation will stop.

7. OPERATION

STARTING THE DEVICE

If you have selected the desired mode from the list, set the switch to the appropriate position and the appliance will start the requested programme according to the instructions.

According to the instructions you have given, the fan will either run continuously or start at the same time, depending on the heating need. In all cases, the need for heating is detected by the temperature controller and the ignition process is started at the appropriate moment. In all cases, the ignition process is started with a 30 sec pre-ventilation. During this pre-ventilation period, the airflow switch detects whether the fan is operating correctly and is able to generate the correct airflow. If the air flow switch detects the correct air flow and the 30 sec pre-ventilation time has expired, the electronics will trigger the spark ignition and simultaneously open the double closing combination solenoid valve. The gas is fed through the pipes and nozzles to the spark plug, where it ignites the gas-air mixture. If the ignition process has been successful and the ionisation flame detector detects a continuous flame pattern, the appliance is in operation and performs its heating function.

In some countries where the use of a gas pressure sensor is required by regulations, it is part of the ignition process that the appliance cannot start until the gas pressure sensor, set according to the local pressure value, detects the predetermined pressure value. The gas pressure sensor is interlocked with the control electronics and if at any time during operation a pressure fluctuation or gas shortage occurs that causes the gas pressure to fall below the preset value, the gas pressure sensor will immediately disable the electronics and the appliance will stop.

ERROR DETECTION (RESET)

During the normal use of the equipment and during start-up, a number of faults may occur. These faults are monitored and detected by various monitoring and intervention safety units. As a rule, three points ensure the safe operation of the equipment:

- Air flow switch
- Ionisation flame detector
- Temperature limiter

Exceptions are appliances that are shipped to countries that require the use of a gas pressure sensor.

Each of the safety intervention units listed above is individually responsible for the safe operation of the appliance and is interlocked with the control electronics, which will immediately stop operation if any fault is detected.

AIR FLOW SWITCH

The airflow switch detects whether the fan has started and is able to deliver the right amount of air (motor not faulty, air intake side not blocked, etc.) If the airflow switch does not switch to the closed position, the control electronics will stop the start-up process and the equipment will signal a fault (RESET), which will be indicated by the illumination of the RED push-button on the control panel. The RESET button is pressed once to cancel the error message, the RED light goes out and the unit automatically restarts.



IONISATION FLAME DETECTOR



The function of the ionisation flame detector is to monitor the flame, the electrode detects the presence of the flame after sparking and monitors it continuously. If the flame is not stable after sparking or if the flame is cut off during operation, the flame detector immediately stops the appliance and signals a fault (RESET) by interlocking with the control electronics. The RED button on the control panel lights up. By pressing the RESET button once, the fault message is cancelled, the RED light goes out and the appliance automatically restarts. If it does not start, contact the service.

TEMPERATURE LIMITER

The temperature limiter is a sensor/intervention unit placed under the casing of the appliance, inside the appliance. Its function is to continuously monitor the internal temperature of the appliance and, if the temperature reaches 140°C, to immediately stop the heating by means of the control unit and interrupt the circuit of the automatic ignition control. Stopping the combustion does not stop the exhaust fan, which continues to operate and cools the appliance. Re-ignition of the appliance is automatic only after cooling back to operating temperature.

SWITCHING OFF THE EQUIPMENT

Turn the on/off switch on the control box to the „off” position, close the gas shut-off valve in front of the appliance, disconnect the appliance from the mains.

7. MALFUNCTIONS AND TROUBLESHOOTING

The following indicator lights on the front of the appliance indicate the operating status of the air heaters:

- RED: fault indicator light

After the fault has been rectified, press the RESET button.

 **WARNING! If the mains connection cable is damaged, replacement should be carried out only by a qualified person or by the service technician to avoid any risk.**

The axial fan that circulates the air is not running:

Possible causes:

- The mains voltage does not reach the motor.
- The fuse has blown.

Troubleshooting options:

- Check the power supply.
- Replace the fuse, if you have inspected it and found it to be bad, find the cause of the high current consumption.
-

THERE IS NO SPARK BETWEEN THE ELECTRODES OF THE IGNITION MODULE:

Possible causes:

- The igniter is contaminated.
- The electrical connection between the ignition head and the automatic control unit is broken.
- The spark gap is too large.
- Automatic control unit has failed.

Troubleshooting options:

- Clean the electrodes of the ignition head.
- Check the electrical connection between the ignition head and the automatic.
- Check the spark gap between the ignition head electrodes.
- Replace the automatic control unit.
-

THE EQUIPMENT WILL NOT OPERATE EVEN AFTER REPEATED IGNITION CYCLES:

Possible causes:

- The solenoid valve has failed.
- Uncertain electrical connection between the ignition head and the automatic.
- Inadequate nozzle pressure.

Troubleshooting options:

- Replace the solenoid valve.
- Check the electrical connection.
- Check the inlet and outlet gas pressures on the solenoid valve
-

THE GAS BURNER LIGHTS UP, BUT GOES OUT SHORTLY AFTERWARDS:

Possible causes:

- The phase and zero are swapped.
- The nozzle pressure is not correct.
- The airflow switch is reset to the rest position.

Troubleshooting options:

- Check the phase position.
- Check the inlet and outlet gas pressures at the solenoid valve plug.
-

THE EQUIPMENT DOES NOT OPERATE AFTER THE FIRST IGNITION CYCLE:

Possible causes:

- The gas tap is turned off.
- The gas line is not properly vented.
- The nozzle pressure is not correct.

Troubleshooting options:

- Open the gas valve.
- Deflate.
- Check the inlet and outlet gas pressures on the solenoid valve gauge.
- Check the position of the air pressure switch and if at rest, check that it is not stuck and clean the switch surroundings if necessary.



WARNING! Always disconnect the appliance from the gas supply if the appliance is not to be used for a long period.

After disconnecting the appliance from the mains, replace the plastic protective caps removed during unpacking on the gas connection elements.

Always use new sealing rings when dismantling and reassembling the gas mains.

Always store the appliance in a dry, clean and safe place to avoid premature ageing and to protect it from possible mechanical damage.

8. MAINTENANCE



WARNING! In the event of prolonged interruption of the operation of the equipment always disconnect the appliance from the gas supply.

After disconnecting the appliance from the mains, replace the plastic protective caps removed during unpacking on the gas connector.

Always use new sealing rings when dismantling and reassembling the gas mains.

Always store the appliance in a dry, clean and safe place to avoid premature ageing and to protect it from possible mechanical damage.



WARNING! Never service an appliance that is live, connected to the gas mains, in use or still hot. The above can cause electric shock or burns.

MAINTENANCE OPERATIONS

The air heater type „LH”, when used in agriculture, does not require any special maintenance apart from the inspection and cleaning after each rotation (see maintenance operations that can be carried out by the customer), but to ensure the safety of operation and long life of the appliance, it is recommended that, at least once a year, it is inspected by a professional service technician or a specialist.

MAINTENANCE OPERATIONS THAT CAN BE CARRIED OUT BY THE CUSTOMER:

- a) Checking and cleaning the enclosure:
Dust the outside of the casing with a brush or air, then make sure there are no burn-outs, abrasions, etc.
- b) Visually check the condition of the flame trap disc through the exhaust outlet. Burn-out, discoloration is clearly visible.
- c) Check the suspensions, making sure the load is evenly distributed on all suspensions. You can check this by moving the suspension elements one by one.
- d) Axial fans should be cleaned with air.
- e) Check the status of the air flow switch operated by the axial fan of the air flow extinguisher, and its readiness for manual switching. Manually operate the microswitch twice, three times, check the existence of the spring with the naked eye. If necessary, clean with low air pressure.

If the operating conditions of the device (environment with pollutants, e.g. dust, vapours, etc.) require it, inspection and cleaning operations should be carried out more frequently! The main reason for this is that dust deposits on the fans reduce the efficiency of the unit and can significantly increase its weight, which is an important factor for the safety of the suspension. The appliance is suitable for heating greenhouses, agricultural livestock buildings, livestock buildings (poultry, pigsties, etc.). Warning: If the appliance is used in an agricultural context (e.g. livestock farming, etc.) or in an area where flammable substances may be released into the air during the maintenance or cleaning of the site, it is strictly forbidden to operate the appliance during this period! In the case of livestock farming, the unit must be cleaned after each rotation!



WARNING! Before any maintenance operation, switch the appliance off by turning off the main power switch. and unplugging the electrical plug on the back of the appliance, the appliance must be disconnected from the mains power supply.



WARNING! If the operating conditions of the instrument (environment with pollutants, e.g. dust, corrosive vapours) require it, inspection and cleaning operations should be carried out more frequently. should be carried out more frequently! The main reason for this is that dust deposits on the emitter body reduce the efficiency of the device and can significantly increase the weight, which is an important factor for the safety of the suspension.

MAINTENANCE OPERATIONS TO BE CARRIED OUT ONLY BY A PROFESSIONAL SERVICE

 **WARNING! Never service an appliance that is live, connected to the gas mains, in use or still hot. The above can cause electric shock or burns.**

All maintenance operations and interventions that require disassembly of the appliance:

- a) Nozzle pressure check (on the secondary outlet of a combined solenoid valve)
- b) Checking the condition of the upstream pressure relief valve
- c) Cleaning the gas filter.
- d) Checking the condition of the air pressure (differential) switches.
- e) Check the presence of protective earthing.
- f) Check electrical connection.
- g) Check of the air flow axial fan.

GAS EXCHANGE

 **WARNING! If the appliance is to be operated with a different gas (e.g. propane instead of natural gas), always contact the distributor or a specialist workshop!**

 **WARNING! This operation may only be carried out by a specialist service technician or a specialist authorised by the manufacturer.**

 **WARNING! It is strictly forbidden to cover the fan or the exhaust outlet of the appliance!**

9. TECHNICAL PARAMETERS

Fuel.....Natural gas, Propane

System pressure up to the solenoid valve:

Minimum.....20 mbar

Maximum.....60 mbar

Fan motor180 W

Electrical connection.....230V/50Hz/2.1A

Current consumption.....1,5 A

Weight.....22,5 kg

10. ANNEXES

ANNEX 1: LH AIR HEATER PERFORMANCE DATA AND GAS CONSUMPTION

CAPACITY AND GAS CONSUMPTION						
TYPE	LH-30	LH-40	LH-50	LH-60	LH-70	LH-80
Power output [kW]	30	40	50	60	70	80
Natural gas [m ³ /h]	3,17	4,23	5,29	6,30	7,35	8,40
Propane [kg/h]	2,5	3,34	4,19	5,01	5,84	6,71

ANNEX 2: AIR DELIVERED BY LH AIR HEATER

VOLUME OF AIR DELIVERED						
TYPE	LH-30	LH-40	LH-50	LH-60	LH-70	LH-80
Fan air flow [m ³ /h]	3600					

ANNEX 3: NUMBER OF BURNERS FOR LH AIR HEATER

QUANTITY OF BURNERS						
TYPE	LH-30	LH-40	LH-50	LH-60	LH-70	LH-80
Quantity of nozzles [pcs]	5	5	5	5	5	5
Natural Gas						
Nozzle pressure [mbar]	10	10	10	10	10	10
Propane						
Nozzle pressure [mbar]	20	20	20	20	20	20

11 GUARANTEE AND SERVICES

PRESERVE THIS WARRANTY

<p>Type:</p> <p>Serial no.:</p> <p>Date of purchasing:</p>
--

LIMITED GUARANTEE *

The manufacturer guarantee the costumer that the product and its parts are free from material and production failures. During normal use the warranty is 2 years. This warranty concerns the first retail customer.

The guarantee concerns the costs of laboratory investigations and the parts, which are needed for proper operation. The delivery and unforeseeable costs belong also to the mending costs and do not contain compensation costs.

Guarantee mending can only be realized by authorized retailer or service centre.

The guarantee does not concerns the following failures, which are caused by: improper using, damaging, neglect, accident, lack of maintenance, normal attrition, transformation, modification and operation influenceable factor, contaminated fuel, installation of non-suitable part and mending which is done by not authorized retailer or service station.

The regular maintenance is the owner's responsibility.

The manufacturer does not assume the responsibility in case of accidentally happened or directly caused mistake respectively improper using.

***We reserve the right to change of this specification without extra notification. The guarantee can be applied in accordance with above defined.**

Additional guarantee is not accepted.

Guarantee servicing

If your appliance needs guarantee service in that case it can be requested at nearest authorized service station giving in the appliance for repairs.

Mending services

Take the appliance to the nearest authorized service station. If the device is not under guarantee the service cost will be invoiced to the costumer at defined price. The service centres are independent from one another and may have different owners. We reserve the right to change of this specification without extra notification. If you would like to contact us the type and serial number of device always be at hand. In case of other needed information write to the distributor.



PAKOLE

www.pakole.com

PAKOLE TRADE Ipari és Kereskedelmi Kft.

H-8000 Székesfehérvár, Börgöndi út 8-10.

www.pakole.hu

mail@pakole.hu

Tel.: +36 22 316 484