



PAKOLE

OPERATION AND MAINTENANCE DOCUMENTATION

AIR CURTAINS



Type :

ACR 1000W	ACR 1000E	ACR 1000C
ACR 1500W	ACR 1500E	ACR 1500C
ACR 2000W	ACR 2000E	ACR 2000C

ACR_008_039_011_221021_V004_en

Contents

1.	GENERAL AND SAFETY PRINCIPLES	3
2.	PURPOSE OF THE DEVICE	3
3.	BASIC TECHNICAL PARAMETERS	4
4.	HEAT OUTPUT RANGES.....	4
5.	INSTALLATION	6
6.	CONTROL PANEL	10
7.	ACR DOOR SWITCH.....	10
8.	DIAGRAMS OF ELECTRICAL CONNECTIONS.....	11
9.	DIMENSIONS OF THE ACR 1000-1500-2000 W, E, C CURTAINS.....	16
10.	OPERATION AND MAINTENANCE.....	17
11.	TROUBLESHOOTING AND TECHNICAL PROBLEMS.....	17

1. GENERAL AND SAFETY PRINCIPLES

The ACR air curtains are manufactured in compliance with the rules and standards concerning quality, ecology, utility and work comfort. Before starting the device be sure to read the Manual carefully.

The ACR air curtains are delivered ready-to-use in a cardboard package that is to protect from any mechanical damages. The package consists of: the device, the Manual (Operation and Maintenance Documentation) and the Guarantee. If the optional automatic control ordered, it shall be delivered in a separate package. Make sure all the aforementioned elements are in the package immediately after the delivery. In the absence of any element, please fill in the suitable carrier document.

NOTICE!

- Do not use the curtain in rooms containing any flammable and/or combustible substances, biological substances or in environments with corrosive air components.
- Do not use the curtain in rooms with relative humidity above 80%
- Do not leave the curtain ON unattended for long periods
- Do not use the curtain without proper grounding
- Do not turn the curtain on without protective cover in place
- Before conducting any maintenance or cleaning work or during the break in operation for an extended period of time, make sure you unplug the power cable
- To connect the air curtain, use a supply cable with a fork that protects against unintended disconnecting from the power
- When the air curtain is connected directly to the cable, please make sure there is a splitter protecting against any undesired disconnecting
- Pay special attention while transporting the device not to damage the casing
- When the device is being operated, ensure the safety rules in accordance with the labor standards relating to the operation of any electrical devices
- Do not place any objects on the curtain or reduce the airflow in order to ensure the fire safety and if sparks or a damaged supply cable noticed, discontinue the operation immediately
- Electricity network, to which the curtain is connected, should be protected against overloading and short circuit

CAUTION!

- To avoid serious danger of electric shock, installation must be performed by a qualified electrician
- To avoid the serious danger to electric shock disconnect the power supply prior to conducting any repair or maintenance work
- Any leakage repairs of the heating medium in the device, of which pipes are under pressure, is strictly prohibited
- Cut-off/stop valve must be used to supply a heating medium
- It is prohibited to connect grounding-type plug to water pipe, gas tubes, lightning conductors, telephone or antenna network
- Wait for at least 3 hours before connecting the device from the power supply if the temperature while transporting is below zero

NOTICE !

 **Before mounting the device, read the manual carefully and adhere to the rules concerning the mounting procedures. Not applying to the rules may result in the inappropriate functioning of the device and the loss of the guarantee rights.**

Pay special attention when working with electrical elements of the device.

2. PURPOSE OF THE DEVICE

The air curtain is intended to be used in regions with a moderate and cold climate, in spaces where temperature ranges from -10 to +40°C, in conditions free from external factors such as pollens and hydrometeor (horizontal precipitation).

In winter, air curtains protect against heat loss in rooms by directing an airstream across the entrance way and preventing cold air from entering the heated space.. In summer, the curtains may be used as cooling devices preventing the entry of hot air and pollutants from outside.

The ACR air curtains are designed to protect against heat losses in buildings of medium and high capacity and with a required mounting height is of 4 m such as:

- supermarkets, large retail space,
- car showrooms and service stations,
- sports and show halls,
- exhibition surfaces

3. BASIC TECHNICAL PARAMETERS

Parameters		Curtain with water heater			Curtain with electric heater		
		ACR 1000W	ACR 1500W	ACR 2000W	ACR 1000E	ACR 1500E	ACR 2000E
Length of unit	m	1	1.5	2	1	1.5	2
Max. installation height	m	4	4	4	4	4	4
Max. air output	m ³ /h	1200 / 1550 / 2000	2200 / 3000 / 3600	2900 / 4000 / 4800	1200 / 1550 / 2000	2200 / 3000 / 3600	2900 / 4000 / 4800
Heat output *	kW	10–16	20–29	25–40	4–7	6.5–11	8.5–14
Temperature increase**	Δt	-	-	-	12	13	14
Max. working pressure	MPa	1.6	1.6	1.6	-	-	-
Connection nozzles Ø	Inch	1/2"	1/2"	1/2"	-	-	-
Motor power consumption	V/Hz A	230/50 1.4A	230/50 1.8A	230/50 2.4A	230/50 1.4A	230/50 1.8A	230/50 2.4A
Motor power	W	37 / 80 / 160	51 / 106 / 220	75 / 162 / 320	37 / 80 / 160	51 / 106 / 220	75 / 162 / 320
Electric heater consumption***	V/Hz A	-	-	-	400/50 12.6A	400/50 19.1A	400/50 25.1A
Weight with water / without water	kg	18.0 / 16.5	22.6 / 20.5	31.0 / 28.0	17	21.5	29
Sound level	dB (A)	44 / 49 / 59	45 / 49 / 61	46 / 49 / 61	44 / 49 / 59	45 / 49 / 61	46 / 49 / 61
Protection Class	IP	IP21	IP21	IP21	IP21	IP21	IP21

Parameters		Curtain without heater		
		ACR 1000C	ACR 1500C	ACR 2000C
Length of unit	m	1	1.5	2
Max. installation height	m	4	4	4
Max. air output	m ³ /h	1250 / 1600 / 2100	2250 / 3100 / 3700	3000 / 4200 / 5000
Heat output *	kW	-	-	-
Temperature increase**	Δt	-	-	-
Max. working pressure	MPa	-	-	-
Connection nozzles Ø	Inch	-	-	-
Motor power consumption	V/Hz A	230/50 1.4A	230/50 1.8A	230/50 2.4A
Motor power	W	37 / 80 / 160	51 / 106 / 220	75 / 162 / 320
Electric heater consumption***	V/Hz A	-	-	-
Weight with water / without water	kg	15	18.5	25
Sound level	dB (A)	45 / 50 / 60	46 / 50 / 61	47 / 50 / 61
Protection Class	IP	IP21	IP21	IP21

* Heat output for water agent 90/70 and inlet air temperature 0°C.

** Temperature increase for 18°C ambient air.

*** Power consumption for ambient air temperature 18°C and cable length 10m.

Energy consumption [A] goes higher in relation to decrease of air inlet temperature or extension of supply cables length.

Noise level measured in distance of 3 m in open space building.

4. HEAT OUTPUT RANGES

ACR 1000-1500-2000 W AIR CURTAINS WITH WATER HEATER

		ACR 1000W																													
Inlet/outlet water temperature		50/30					60/40					70/50					80/60					90/70									
Inlet air temperature		0	5	10	15	20	0	5	10	15	20	0	5	10	15	20	0	5	10	15	20	0	5	10	15	20	0	5	10	15	20
		III. max. air flow – 2000 m³/h																													
Heat output [kW]		6,6	5,6	4,6	3,6	2,6	9,0	7,9	6,9	5,8	4,8	11,3	10,3	9,2	8,1	7,1	13,7	12,6	11,5	10,5	9,4	16,0	14,9	13,9	12,8	11,7					
Outlet air temperature [°C]		11,4	14,9	18,3	21,9	25,4	14,9	18,3	21,8	25,2	28,7	18,4	21,8	25,2	28,7	32,1	21,9	25,3	28,7	32,1	35,5	25,4	28,8	32,2	35,6	39,0					
Water flow [m ³ /h]		0,2	0,2	0,2	0,1	0,1	0,4	0,3	0,3	0,2	0,2	0,5	0,4	0,4	0,3	0,3	0,6	0,5	0,5	0,4	0,4	0,7	0,6	0,6	0,5	0,5					
Pressure drop [kPa]		1,0	1,0	0,6	0,6	0,3	2,0	2,0	1,0	1,0	1,0	4,0	3,0	2,0	2,0	1,0	5,0	5,0	4,0	3,0	2,0	7,0	6,0	5,0	5,0	4,0					
		II. max. air flow – 1550 m³/h																													
Heat output [kW]		5,9	5,0	4,2	3,3	2,4	7,9	7,0	6,1	5,3	4,4	10,0	9,1	8,2	7,2	6,3	12,0	11,1	10,2	9,2	8,3	14,0	13,1	12,2	11,2	10,3					
Outlet air temperature [°C]		12,5	15,8	19,1	22,4	25,8	16,4	19,6	22,9	26,2	29,5	20,3	23,5	26,8	30,0	33,3	24,2	27,4	30,6	33,9	37,1	28,0	31,3	34,5	37,7	40,9					
Water flow [m ³ /h]		0,2	0,2	0,1	0,1	0,1	0,3	0,3	0,2	0,2	0,2	0,4	0,4	0,3	0,3	0,2	0,5	0,4	0,4	0,4	0,3	0,6	0,5	0,5	0,5	0,4					
Pressure drop [kPa]		1,0	1,0	0,5	0,5	0,2	2,0	2,0	1,0	1,0	1,0	3,0	2,0	2,0	1,0	1,0	4,0	3,0	3,0	2,0	2,0	6,0	5,0	4,0	4,0	3,0					
		I. max. air flow – 1200 m³/h																													
Heat output [kW]		5,3	4,5	3,8	3,0	2,3	7,0	6,3	5,5	4,7	3,9	8,8	8,0	7,2	6,4	5,6	10,5	9,7	8,9	8,1	7,3	12,2	11,4	10,6	9,8	9,0					
Outlet air temperature [°C]		13,7	16,8	19,9	23,0	26,2	18,0	21,1	24,4	27,2	30,3	22,3	25,3	28,4	31,5	34,5	26,6	29,6	32,7	35,7	38,8	30,9	33,9	36,9	40,0	43,0					
Water flow [m ³ /h]		0,2	0,2	0,1	0,1	0,1	0,3	0,2	0,2	0,2	0,1	0,3	0,3	0,3	0,2	0,2	0,4	0,4	0,4	0,3	0,3	0,5	0,5	0,4	0,4	0,4					
Pressure drop [kPa]		1,0	0,8	0,5	0,5	0,2	1,0	1,0	1,0	0,7	0,6	2,0	2,0	1,0	1,0	1,0	3,0	3,0	2,0	2,0	1,0	4,0	4,0	3,0	3,0	2,0					

ACR 1500W																									
Inlet/outlet water temperature	50/30					60/40					70/50					80/60					90/70				
Inlet air temperature	0	5	10	15	20	0	5	10	15	20	0	5	10	15	20	0	5	10	15	20	0	5	10	15	20
III. max. air flow – 3600 m³/h																									
Heat output [kW]	13,5	11,7	10,0	8,2	6,4	17,4	15,6	13,8	12,1	10,3	21,3	19,5	17,7	15,9	14,1	25,1	23,3	21,6	19,7	18,0	29,0	27,2	25,4	23,6	21,8
Outlet air temperature [°C]	11,9	15,4	18,9	22,5	26,0	15,1	18,6	22,1	25,7	29,2	18,3	21,8	25,3	28,9	32,4	21,5	25,0	28,6	32,0	35,6	24,7	28,2	31,7	35,2	38,7
Water flow [m³/h]	0,5	0,4	0,3	0,2	0,2	0,6	0,6	0,5	0,4	0,3	0,8	0,7	0,7	0,6	0,5	1,0	0,9	0,8	0,7	0,7	1,2	1,1	1,0	0,9	0,8
Pressure drop [kPa]	4,0	3,0	2,0	1,0	1,0	8,0	6,0	4,0	3,0	2,0	12,0	10,0	8,0	6,0	5,0	17,0	14,0	12,0	10,0	8,0	22,0	19,0	17,0	14,0	12,0
II. max. air flow – 3000 m³/h																									
Heat output [kW]	12,5	10,9	9,3	7,8	6,1	16,1	14,4	12,8	11,2	9,6	19,6	17,9	16,3	14,7	13,1	23,1	21,4	19,8	18,2	16,6	26,5	24,9	23,3	21,6	20,0
Outlet air temperature [°C]	12,7	16,1	19,5	22,9	26,3	16,2	19,6	23,0	26,4	29,8	19,7	23,1	26,5	29,9	33,2	23,2	26,5	29,9	33,3	36,7	26,6	30,0	33,4	36,7	40,1
Water flow [m³/h]	0,4	0,4	0,3	0,2	0,2	0,6	0,5	0,4	0,4	0,3	0,7	0,7	0,6	0,5	0,5	0,9	0,8	0,8	0,7	0,7	1,1	1,0	0,9	0,8	0,8
Pressure drop [kPa]	4,0	3,0	2,0	1,0	0,6	6,0	5,0	4,0	3,0	2,0	10,0	8,0	6,0	5,0	4,0	14,0	12,0	10,0	8,0	7,0	18,0	16,0	14,0	12,0	10,0
I. max. air flow – 2200 m³/h																									
Heat output [kW]	11,0	9,7	8,4	7,0	5,7	14,0	12,6	11,3	9,9	8,6	16,9	15,5	14,2	12,9	11,5	19,8	18,4	17,1	15,7	14,4	22,7	21,3	20,0	18,6	17,3
Outlet air temperature [°C]	14,2	17,4	20,6	23,7	26,9	18,2	21,3	24,5	27,7	30,9	22,1	25,3	28,5	31,6	34,8	26,1	29,2	32,4	35,6	38,7	30,0	33,1	36,3	39,5	42,6
Water flow [m³/h]	0,4	0,3	0,2	0,2	0,1	0,5	0,4	0,4	0,3	0,3	0,6	0,6	0,5	0,4	0,4	0,8	0,7	0,6	0,6	0,5	0,9	0,8	0,8	0,7	0,6
Pressure drop [kPa]	3,0	2,0	1,0	1,0	0,6	5,0	4,0	3,0	2,0	1,0	7,0	6,0	5,0	4,0	3,0	10,0	8,0	7,0	6,0	5,0	12,0	11,0	10,0	8,0	7,0

ACR 2000W																									
Inlet/outlet water temperature	50/30					60/40					70/50					80/60					90/70				
Inlet air temperature	0	5	10	15	20	0	5	10	15	20	0	5	10	15	20	0	5	10	15	20	0	5	10	15	20
III. max. air flow – 4800 m³/h																									
Heat output [kW]	19,5	17,2	14,8	12,4	9,9	24,7	22,3	19,9	17,5	15,1	29,8	27,4	25,0	22,6	20,2	34,9	32,5	30,1	27,7	25,3	40,0	37,6	35,2	32,8	30,4
Outlet air temperature [°C]	12,5	16,0	19,5	23,0	26,5	15,7	19,2	22,7	26,2	29,7	18,9	22,4	25,9	29,4	32,9	22,1	25,6	29,1	32,6	36,1	25,2	28,7	32,2	35,7	39,2
Water flow [m³/h]	0,7	0,6	0,5	0,4	0,2	0,9	0,8	0,7	0,6	0,5	1,1	1,0	0,9	0,8	0,7	1,4	1,2	1,1	1,0	0,9	1,6	1,5	1,4	1,3	1,2
Pressure drop [kPa]	9,0	6,0	4,0	3,0	1,0	15,0	12,0	9,0	7,0	5,0	22,0	19,0	15,0	12,0	9,0	32,0	27,0	23,0	19,0	15,0	42,0	37,0	32,0	27,0	23,0
II. max. air flow – 4000 m³/h																									
Heat output [kW]	18,2	16,0	13,8	11,7	9,4	22,8	20,7	18,5	16,3	14,1	27,5	25,3	23,1	20,9	18,8	32,1	29,9	27,7	25,5	23,4	36,6	34,5	32,3	30,1	27,9
Outlet air temperature [°C]	13,3	16,7	20,1	23,5	26,8	16,8	20,2	23,6	27,0	30,3	20,3	23,7	27,0	30,4	33,8	23,7	27,1	30,5	33,8	37,2	27,1	30,5	33,9	37,3	40,6
Water flow [m³/h]	0,6	0,5	0,4	0,3	0,2	0,8	0,7	0,6	0,5	0,4	1,0	0,9	0,8	0,7	0,6	1,2	1,1	1,0	0,9	0,8	1,4	1,3	1,2	1,1	1,0
Pressure drop [kPa]	7,0	5,0	4,0	2,0	1,0	12,0	10,0	7,0	5,0	4,0	19,0	16,0	13,0	10,0	8,0	26,0	22,0	19,0	16,0	13,0	35,0	30,0	26,0	22,0	19,0
I. max. air flow – 2900 m³/h																									
Heat output [kW]	15,9	14,1	12,3	10,5	8,7	18,8	18,0	16,2	14,4	12,6	23,6	21,8	20,0	18,2	16,4	27,4	25,6	23,8	22,0	20,2	31,2	29,4	27,6	25,8	24,0
Outlet air temperature [°C]	15,0	18,1	21,3	24,4	27,5	18,9	22,1	25,2	28,4	31,5	22,9	26,0	29,2	32,3	35,5	26,8	29,9	33,1	36,2	39,4	30,7	33,8	37,0	40,1	43,3
Water flow [m³/h]	0,5	0,4	0,4	0,3	0,2	0,7	0,6	0,5	0,4	0,4	0,8	0,8	0,7	0,6	0,5	1,0	0,9	0,9	0,8	0,7	1,2	1,1	1,0	1,0	0,9
Pressure drop [kPa]	5,0	4,0	3,0	2,0	1,0	9,0	7,0	5,0	4,0	3,0	13,0	11,0	9,0	7,0	5,0	18,0	16,0	13,0	11,0	9,0	24,0	21,0	18,0	16,0	13,0

ACR 1000-1500-2000 E AIR CURTAINS WITH ELECTRIC HEATER

	ACR 1000E					ACR 1500E					ACR 2000E				
Inlet air temperature [°C]	0	5	10	15	20	0	5	10	15	20	0	5	10	15	20
Heat output [kW]	7,0	7,0	7,0	7,0	7,0	11,0	11,0	11,0	11,0	11,0	14,0	14,0	14,0	14,0	14,0
Outlet air temperature [°C]	12	18	22	27	32	13	18	23	28	33	14	19	24	29	34

ACR E series (with electric heater) are based on a new type of PTC electric coils J It is a modern and safe solution, additional advantages of PTC heaters

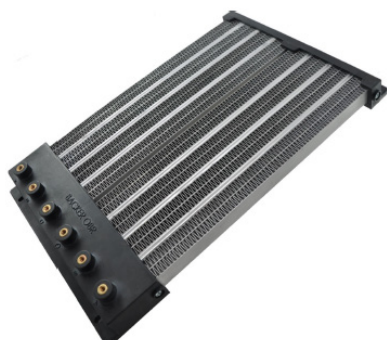

- Lack of voltage on surface of electric coil
- Significantly lower coil temperature in comparison to old type of electric heaters (e.g. heating wires, spirals)
- Large heat exchange surface (surface of contact of the heat exchanger with heated air)
- Fully automatic heat control depending on air flow
- Complete elimination of the risk of system overheating due to self regulating heating modules (heat capacity automatically reduces when air flow goes down)
- Low energy consumption

5. INSTALLATION

When deciding on the air curtain position you should take into account such factors as:

- Ease of access for servicing,
- Access to water and electricity supplies

It is recommended to install the air curtain in position above the entrance opening, on the wall or under the ceiling, on support pins or horizontal mounting brackets. It is also possible to mount it vertically to a wall or other structure using vertical mounting brackets. It's important to make sure that the unit is properly levelled. In case of positioning in a different way than horizontal or vertical, during installation, damage to the fan may occur and in consequence malfunction of the unit.

Inlets and outlets cannot be blocked by any objects. When installing the curtains, keep in mind that you will have free access to the control panel. With larger door openings, it is possible to mount more curtains of the same type, one by one, to create an uninterrupted air flow. The curtain is permanently mounted in either a horizontal or vertical position (on the left/right side of the entrance).

Curtain connection should be done in a serviceable manner, manual shut-off valves should be installed on both nozzles to enable disconnection. In case of a solenoid valve (option - automatics), it must be connected at the water outlet of the device, otherwise it may be damaged. When tightening the pipeline to the exchanger, the heater connection must be protected against torque (which may cause leakage in the exchanger).

Horizontal installation under the ceiling using mounting pins

Installation under the ceiling is done by using 4 M8 pins. In order to hang the device on the pins, drill holes \varnothing 8-9mm in the EPP housing directly in front of the existing holes in the steel inlet grille. The exact location is indicated by special tags on the EPP housing. The pins should be screwed into the nippers at a depth of 10-14mm.

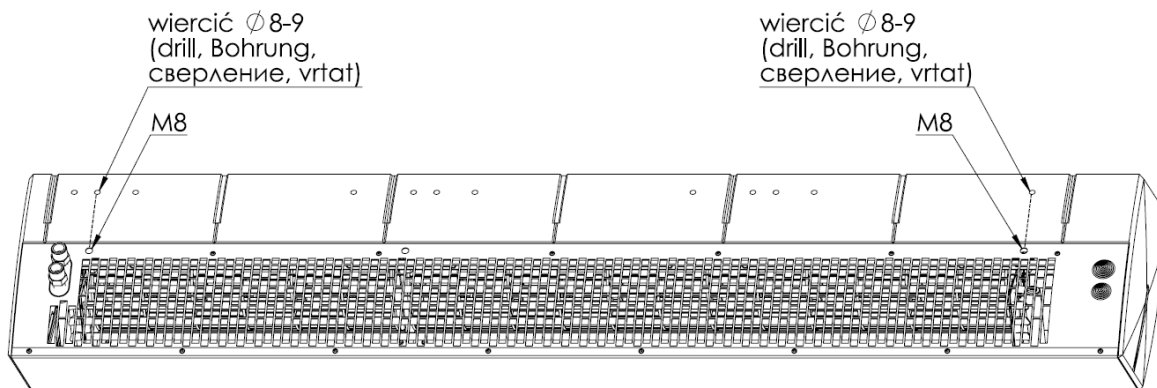

Drawing below shows the position of the mounting holes for the pins

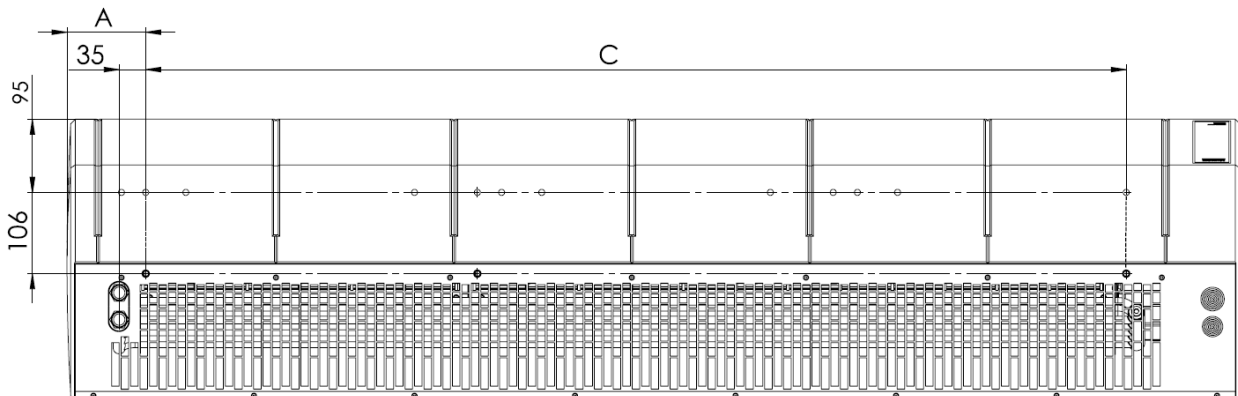

Curtain size	A(mm)	C(mm)	Nuber of pins M8
100	72	857	4
150	104	1295	4
200	157	1712	4

It is important to note that the minimum distance between the device and the ceiling is not less than 150 mm. This will ensure easy access to the water exchanger spigots, cable entries as well as free air flow to the inlet grille.

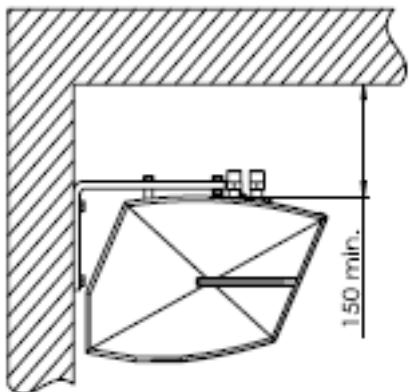

Wall installation by means of a horizontal brackets

The curtain can be mounted to the wall in a horizontal position using 2 mounting brackets to the horizontal system. In the brackets there are Ø9mm holes for M8 screws. In the EPP housing, drill holes Ø 12-13mm in front of existing holes in the steel intake grille. The exact location is indicated by the special tags on the EPP housing and the figure below. Then insert the spacer sleeves into the holes and fix the brackets. Screw the remaining screws into the nuts under the steel intake grille so that both grips are in one plane. Locknuts under the handles are used to secure the screws from unscrewing.

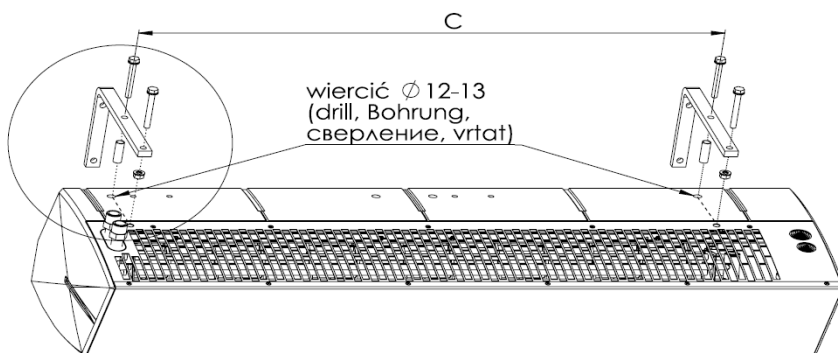
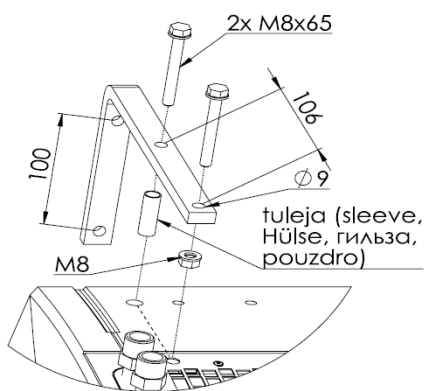

Curtain size	C(mm)	Number of brackets
100	857	2
150	1295	2
200	1712	2

INSTALLATION USING BRACKETS FOR VERTICAL MOUNTING

It is also possible to install the unit vertically with the engine downwards and upwards. Two vertical mounts are used for this purpose. In the brackets there are $\varnothing 9$ mm holes for M8 screws. In the EPP housing, drill holes $\varnothing 12-13$ mm in front of existing holes in the steel intake grille. The exact location is indicated by special tags on the EPP housing and the figure below. Then insert the spacer sleeves into the holes and fix the brackets. Screw the remaining screws into the nuts under the steel intake grille so that both grips are in one plane. Locknuts under the handles are used to secure the screws from unscrewing.

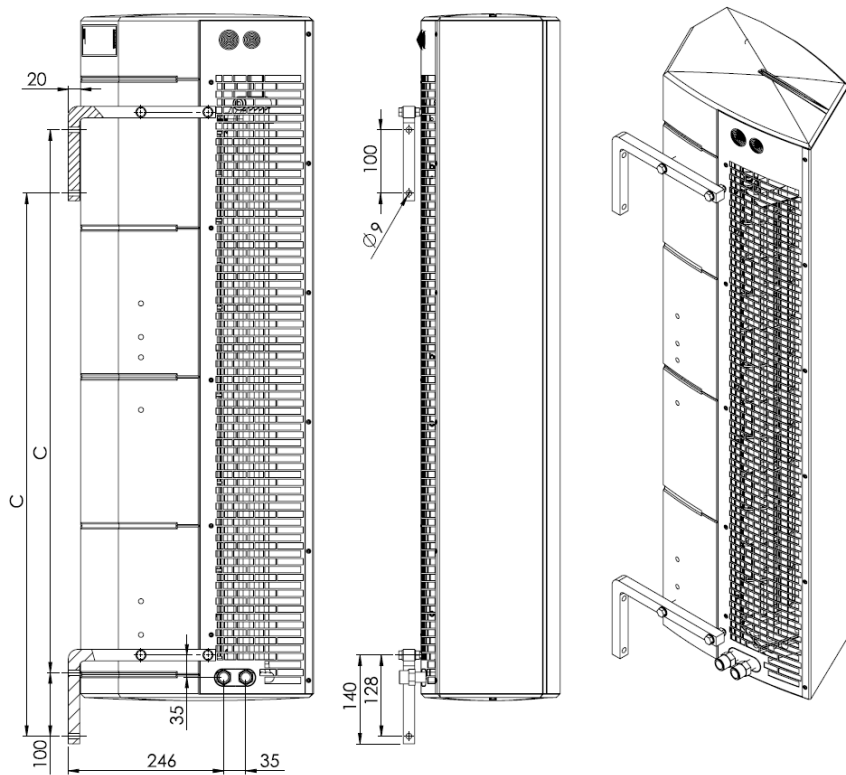

Curtain size	C(mm)
100	857
150	1295
200	1712

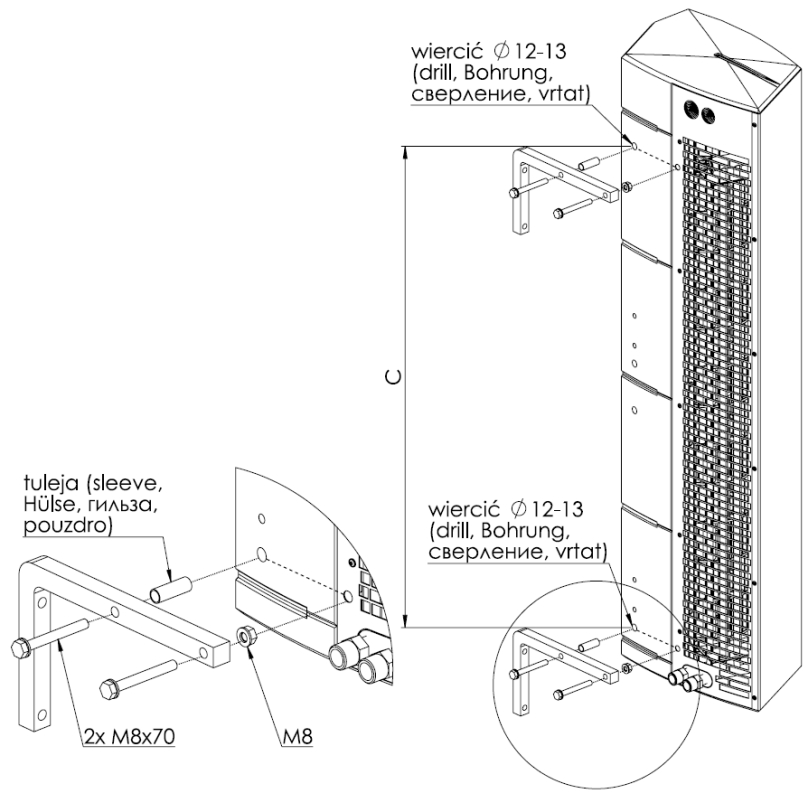

It is important to note that the minimum distance between the unit and the floor for installation with engine at the bottom is not less than 100mm. This allows access to the electrical terminal strip and to the water exchanger vent.

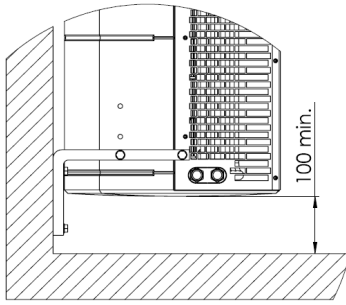

CONNECTION OF HEATING MEDIUM

The connection of the heating medium to the heat curtain, using G 1/2" threaded connections, should be made on the basis of a design by an authorized designer. If the air curtain is connected to a district heating network without a mixing unit, a water filter is required.

In case of horizontal and vertical mounting with nozzles at the top, the exchanger is vented through the nozzles. If the device is mounted vertically with nozzles at the bottom, to vent the exchanger, use a vent which is located on the exchanger collector on the engine side.

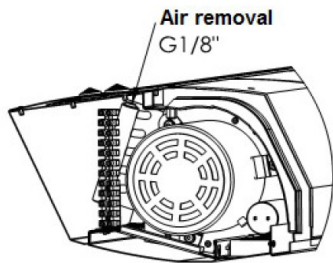

ATTENTION !
 It is necessary to ensure that the unit is properly leveled. When it is mounted in a position other than vertical or horizontal there is a risk of fan damage and unit malfunction

CONNECTING THE POWER SUPPLY AND CONTROL SYSTEM OF THE CURTAIN

To connect the power supply, control and / or bleed the Exchange move out the right lid, which is fastened with the lock to the lower steel housing and the main housing EPP. The lid is disassembled in the direction shown by the arrows in the figure below. The lid should be grasped in the following places indicated in the drawing and should be gradually "released" from the locks for several millimetres. Cable entries for power and control cables are located on the inlet grille.

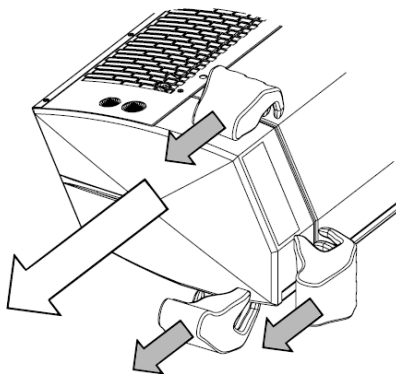

ATTENTION !
 Ensure that no connection wire is clamped between the lid and the rest of the curtains before assembling the lid.

6. CONTROL PANEL

The curtain control is done by using the COMFORT control panel, which allows to adjust the flow and air temperature. The control panel should be located outside the curtain airflow zone. Up to 2 ACR curtains can be connected to one COMFORT panel.



- **Description of the COMFORT control panel switches**
- **ON/OFF** – switching on/off of the machine
- **I-II-III** – fan gear switches, COMFORT terminal strip clamps
 clamp 8 - high speed III
 clamp 7 - middle speed II
 clamp 6 - low speed I
- **HEAT** - when the room temperature is lower than the set value, the thermostat switches on the fan (ACR W, E, C), the electric heater (ACR E) and the valve actuator (ACR W); When the set temperature is reached, the fan is switched off, the valve closes the water flow or the electric heater switches off
- **FAN / COOL** – not supported function, in this settings the device does not work

To install the control panel, unscrew the screw, remove the front cover and panel board, fix the panel to the wall, and replace the panel and cover (installation instructions and fixing kit are included in the package).

7. ACR DOOR SWITCH

The ACR (DC) door switch is an additional element for switching the curtain on/off, depending on the opening of the door. It is designed for indoor installation. It includes:

- Relay cabinet - reed relay switchboard
- Reed relay - Reinforcement for door-fitting, hermetic magnetic switch, consisting of a movable and fixed element

Scheme of the relay cabinet – reed relay interface

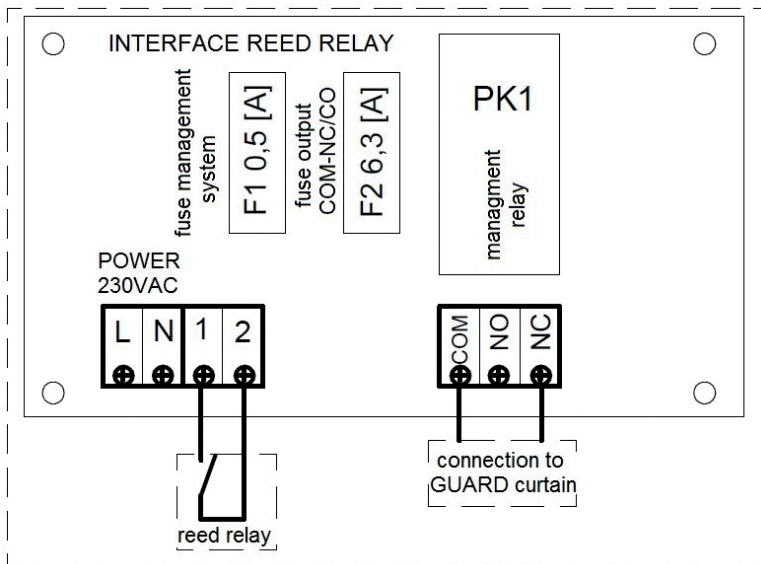

Dimensions of reed relay

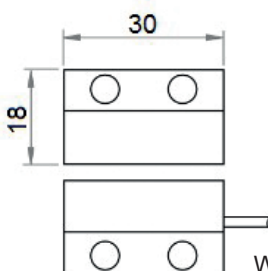

Parameters of relay reed switchboard

- Power supply 230V/50Hz
- Inductive load relay contact 5(A)
- NC magnetic sensor circuit NC
- IP66

When installing the ACR door switch, remove the factory-made jumper:

- **NC-1** for curtain ACR W (curtain with a water heater) / ACR C (curtain without a water heater)
- **NC-COM** for curtain ACR E (curtain with an electric heater)

8. DIAGRAMS OF ELECTRICAL CONNECTIONS

The electrical network to which the curtain will be connected should provide protection against overheating and short circuiting. It is necessary to protect the air curtain by grounding. Electrical installation and connection to the air curtain must be in accordance with applicable building codes and regulations, electrical connection should be carried out by a qualified person familiar with the above instruction. The fan motor has standard internal thermal protection to protect the motor from overheating.

The set does not include: power cord, or main switch.

DIAGRAM OF CONNECTING ONE ACR 1000-1500-2000 W (WATER HEATER) AND C (WITHOUT HEATER) TO THE COMFORT PANEL

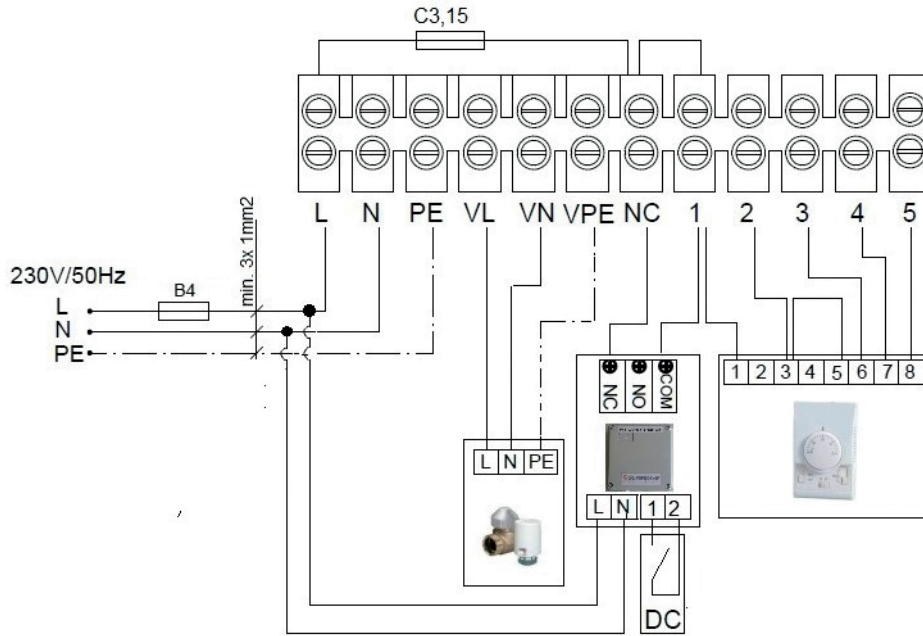

- Power supply 230V / 50Hz; Security system B4; Cross section of power supply cables min. 3 x 1mm²
- Control Panel COMFORT - 3-speed fan control with thermostat, (OMY 5x 1.0mm)
- Actuator valve - control 230V/50Hz (OMY 2 x 0.75mm - TS Lite),

DIAGRAM OF CONNECTING TWO ACR 1000-1500-2000 W (WATER HEATER) AND C (WITHOUT HEATER) TO ONE COMFORT PANEL

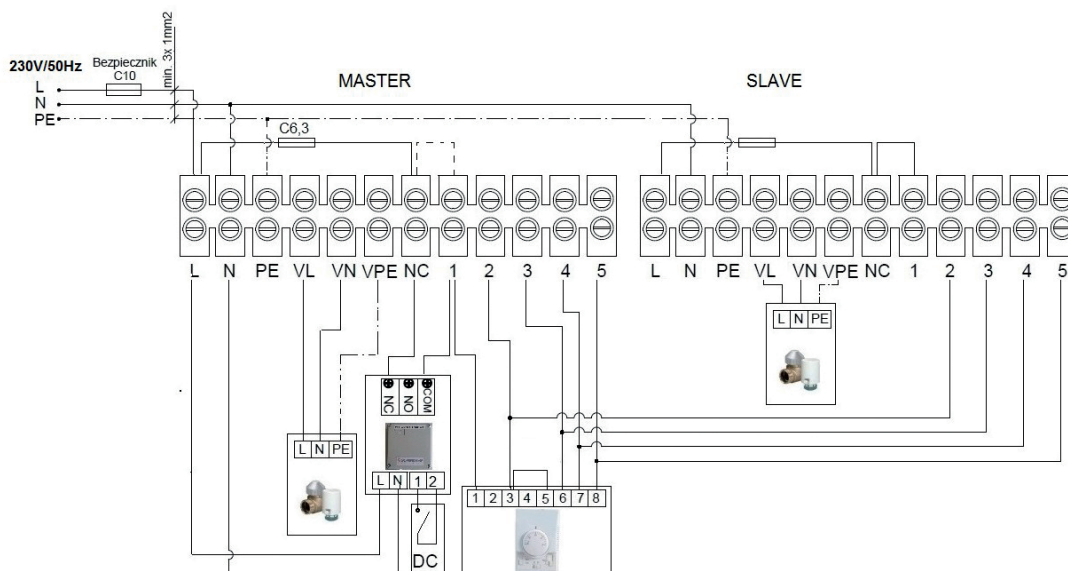

- In the MASTER curtain between the L-NC terminals, replace the factory-made fuse (C 3.15) with C 6.3.
- Power supply 230V/50Hz; protection of the C10 system; cross section of power supply cables min. 3 x 1.5 mm
- COMFORT control panel - 3-speed fan control with thermostat (OMY 5x 1.0mm)
- Actuator valve - control 230V / 50Hz (OMY 2 x 0.75mm - TS Lite),

DIAGRAM OF CONNECTION OF ONE ACR 1000-1500-2000 E CURTAIN (ELECTRIC HEATER) TO THE COMFORT PANEL

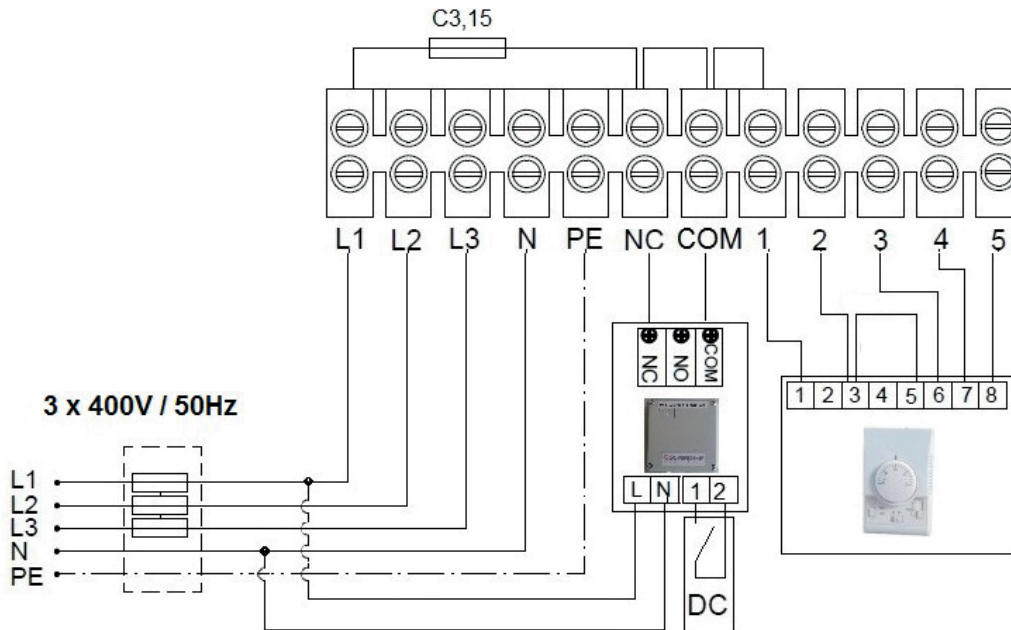

- 400V/50Hz power supply; wire cross section; current protection circuit
 - min. 5 x 2,5 mm₂ for G100E ; (B16)
 - min. 5 x 2,5 mm₂ for G150E; (B20)
 - min. 5 x 4 mm₂ for G200E; (B25)
- Control Panel COMFORT - 3-speed fan control with thermostat, (OMY 5x 1.0mm.)

DIAGRAM OF CONNECTION OF TWO ACR 1000-1500-2000 E CURTAIN (ELECTRIC HEATER) TO ONE COMFORT PANEL

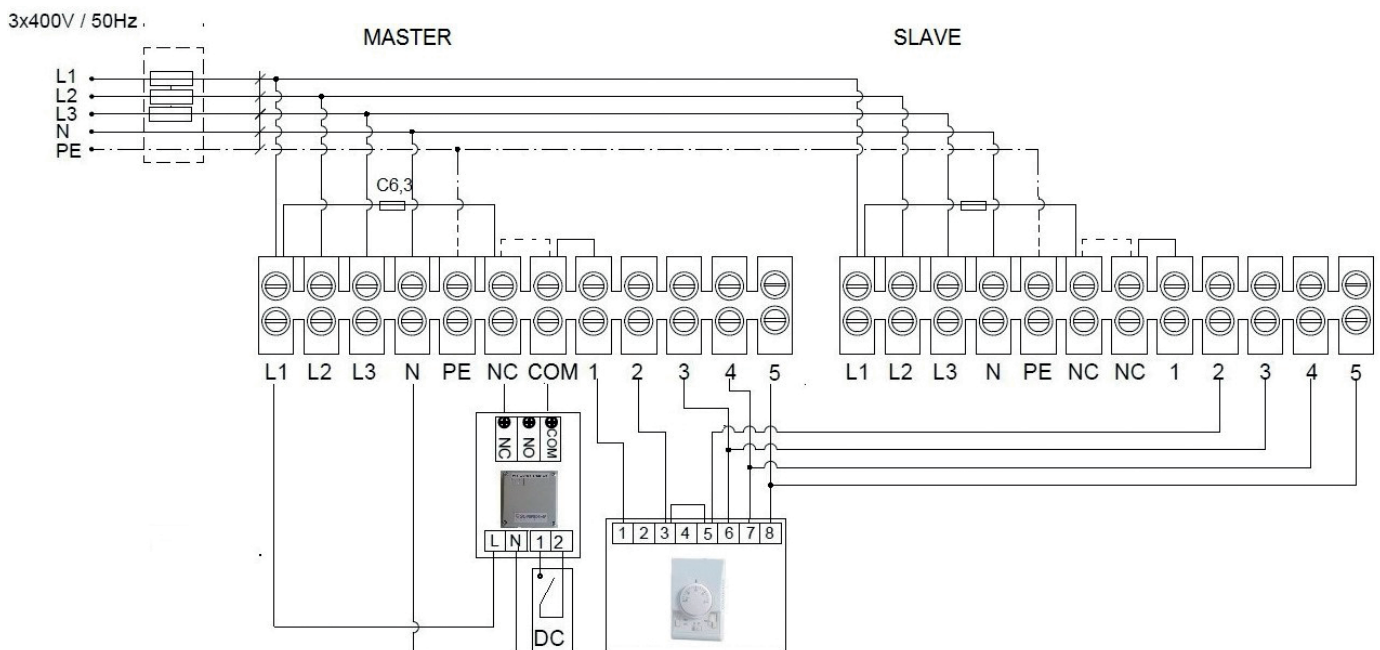

- In the MASTER curtain between the L1-NC terminal, replace the factory-made fuse (C 3.15) with C 6.3 400V / 50Hz power supply; wire cross section; current protection of the system - should be selected according to the parameters of the individual versions of the curtains
- COMFORT control panel - 3-speed fan control with thermostat (OMY 5x 1.0mm.)

DIAGRAM OF CONNECTION OF ONE ACR 1000-1500-2000 E CURTAIN (ELECTRIC HEATER) TO THE COMFORT PANEL

In the summer time, it is possible to switch off the electric heater and use the ACR E curtain as a cold curtain (i.e., fan only, electric heater does not work). In this case, a simple power cut-off installation (shown in the dashed diagram below) must be made. The installation consist in inserting any on/off switch (labelled as "G") into the control circuit between terminal 3 on Comfort Panel and Terminal 2 in the ACR curtain. The on/off switch itself should be installed in a place suitable for the curtain user.

Warning! The Comfort Panel thermostat must be set to max. The on/off switch and the wires to the switch are not included in the scope of delivery

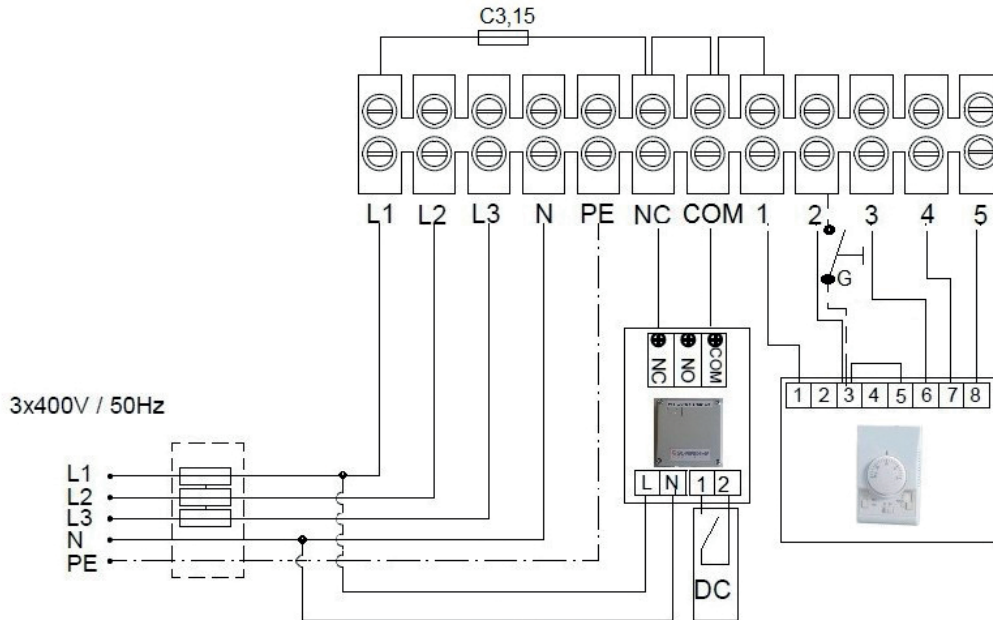

Connection of ACR curtains based on BMS communication module

- The BMS module for ACR curtains allows to monitoring the operation of the curtain (EMERGENCY/FAILURE signal) and switches the curtain on/off from the master BMS system.
- With the use of digital signals 0/1 (potential free contact), the BMS can work with any BMS master protocol without need to convert the signal

CONNECTION DIAGRAM OF ACR 1000-1500-2000 W AND C WITH BMS MODULE

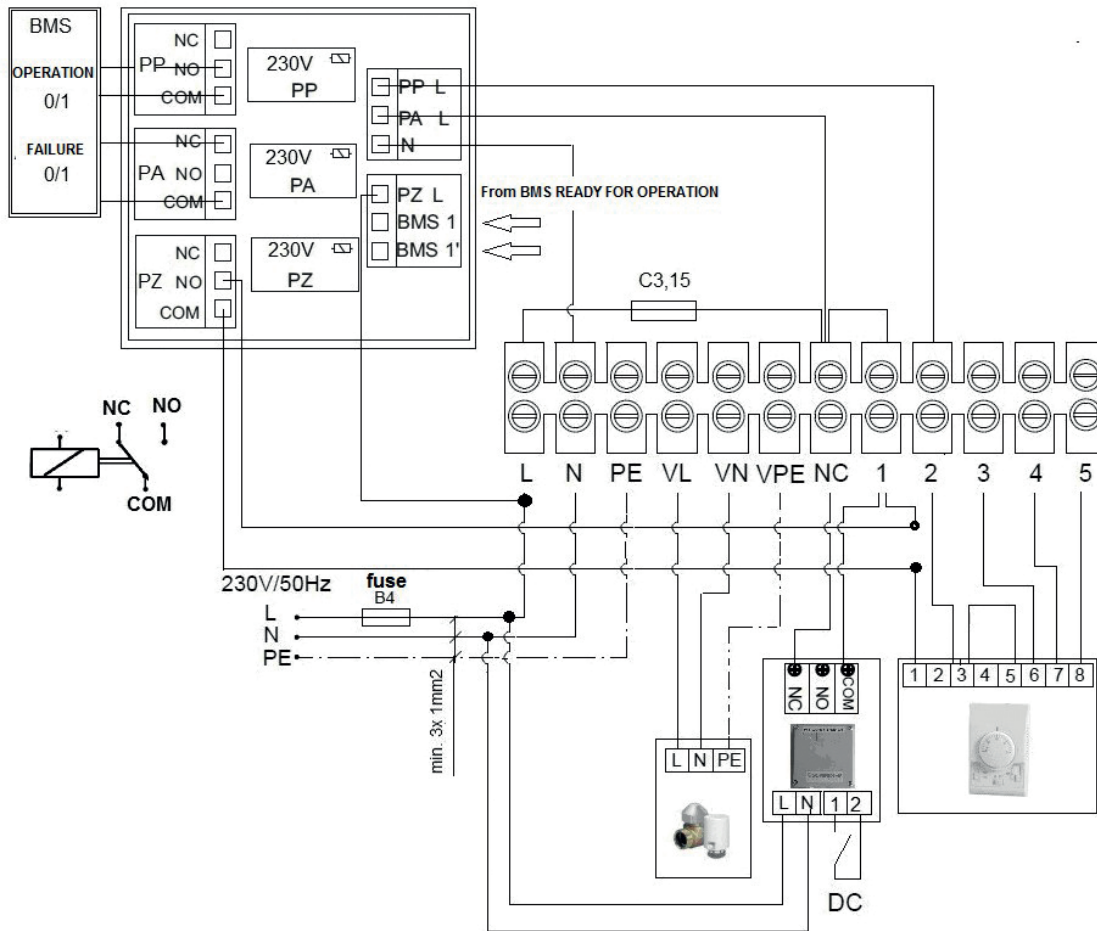

SIGNALS FROM BMS

PP „READY FOR OPERATION”

- Digital signal “1” from the master BMS (potential-free contact) - Curtain ready for operation
- Digital signal “0” from the master BMS system (potential-free contact open) - Curtain disabled

SIGNALS TO BMS - MONITORING THE CURTAIN WORK (NOTE - ON/OFF switch on the COMFORT panel in ON position, “READY FOR OPERATION” signal activated):

PP „OPERATION”

- Digital signal “1” (potential-free contact closed) - information about the operation of the curtain- reed relay on - door opened
- Digital signal “0” (potential-free contact opened) – Reed relay off - door closed
- If the contactor is not used - after the “OPERATION” signal is applied, the curtain operates continuously in the thermostat mode - digital signal “1” (potential-free contact closed)
- When the curtain is switched off via the thermostat - digital signal “0” (potential-free contact open)

PA „FAILURE”

- With proper operation of the curtain - digital signal “0” (potential-free contact opened)
- After triggering the fuse C3,15 - digital signal “1” - curtain failure (potential-free contact closed)

DIAGRAM OF CONNECTION OF ACR 1000-1500-2000 E CURTAIN WITH BMS MODULE

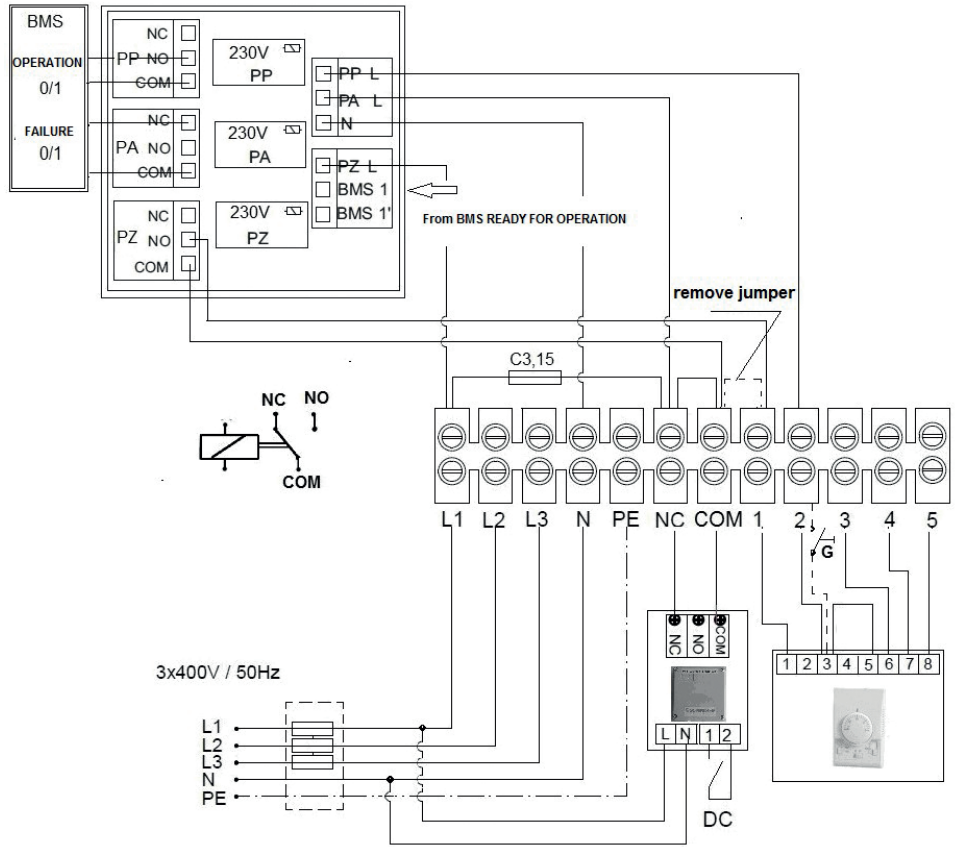

ATTENTION ! While using BMS communication module for ACR electric series remove factory installed jumper between COM-1

SIGNALS FROM BMS

PZ „READY FOR OPERATION”

- Digital signal “1” from the master BMS (potential-free contact closed) - Curtain ready for operation
- Digital signal “0” from the master BMS system (potential-free contact opened) - Curtain disabled

SIGNALS TO BMS - MONITORING THE CURTAIN WORK (NOTE - ON/OFF switch on the COMFORT panel in ON position, “READY FOR OPERATION” 1 signal activated):

PP „OPERATION”

- Digital signal “1” (potential-free contact closed) - information about the operation of the curtain- reed relay on - door opened
- Digital signal “0” (potential-free contact opened) - Reed relay off - door closed
- If the contact is not used - after the “WORKING” signal is applied, the curtain operates continuously in the thermostat mode - digital signal “1” (potential-free contact closed)
- When the curtain is switched off via the thermostat “0” digital signal (potential-free contact opened)

PA „FAILURE”

- With proper operation of the curtain - digital signal “0” (potential-free contact opened)
- After triggering the fuse C3,15 - digital signal “1” - curtain failure (potential-free contact closed)

9. DIMENSIONS OF THE ACR 1000-1500-2000 W, E, C CURTAINS

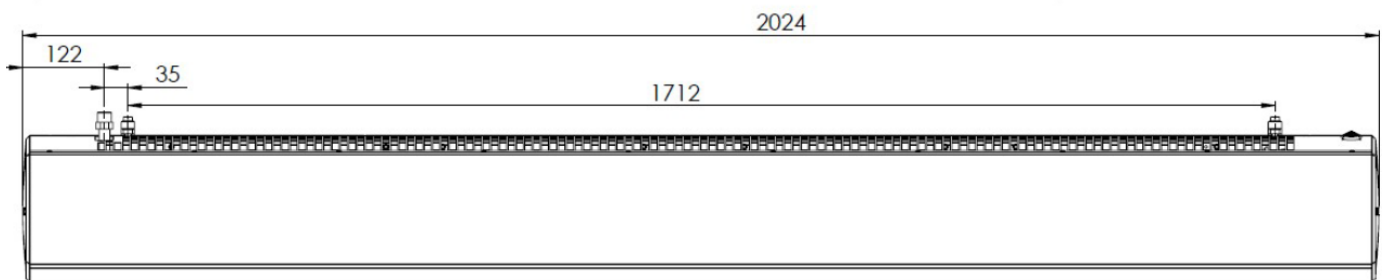
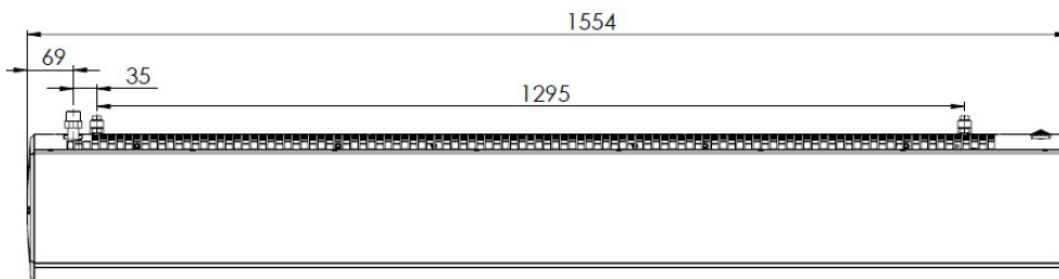
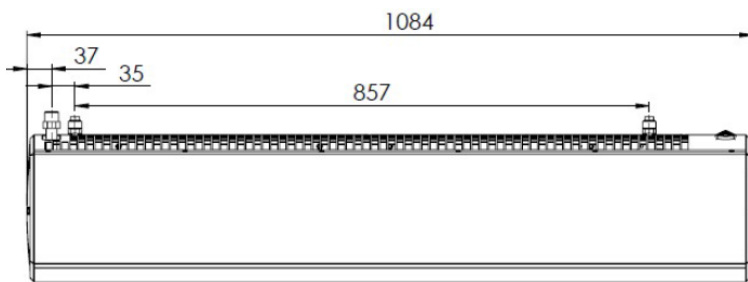
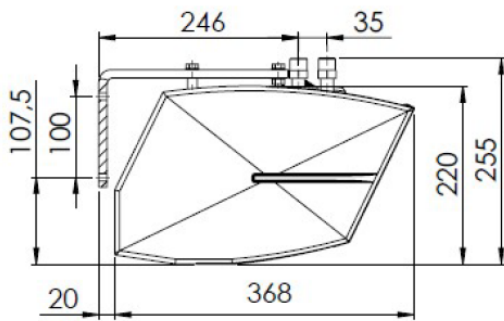

10. OPERATION AND MAINTENANCE

The engine and fan of the ACR air curtains are maintenance-free devices but regular check-ups are advised, especially motor and bearing (fan's rotor should rotate freely, free from any axial and radial throws/run-outs and undesired knocks/rattles).

The heat exchanger requires systematic cleaning of all dirt /impurities off. Before the start of the heating period, the heat exchanger is advised to be cleaned with compressed air directed to the air outlets; there is no need for dismantling of the device.

Pay special attention when cleaning the exchanger's fin due to high possibility of damaging them. If the fin is bent use a special tool. If the device has not been used for a longer period of time, unplug it before the next use.

The heat exchanger is not equipped with any fire protection device. The heat exchanger may be damaged if the room temperature goes below 0°C; anti-freeze liquid must be added to the water circulation/system. Anti-freeze liquid must be appropriate for the material the exchanger is made of (copper) as well as other elements of the hydraulic system/circulation. The liquid must be diluted with water accordingly to the manufacturer's recommendation.

NOTICE !



- **Any and all repair and maintenance works must be conducted with the power off and the heat input disconnected.**
- **Only suitably qualified staff well acquainted with the safety regulations concerning handling with an electrical device must be employed when the device is being installed, started and operated**
- **In the event of coolant leak, when the water system is under pressure, any repairs of the leakage are strictly prohibited.**
- **Any repairs of the device must be conducted only if the device is disconnected from the power supply.**
- **If the device being operated gives metallic clatter, vibration or the level of noise is increasing, check if the mounting of the fan has not become loose – in case of any problems contact the installer of the device or Distributor's Authorized Service immediately.**

11. TROUBLESHOOTING AND TECHNICAL PROBLEMS

Possible problems and solutions are shown below. To eliminate a problem encountered contact the authorized service.

Fault, symptoms	Potential causes	Solutions
No heating, fan not operating	No power supply	Check the power switch Check the power supply Check the power cable – if it is damaged - replace the cable
	Damage to the fan	Replace the motor
	Damage to the switches on control panel	Check the switches – if are damaged – replace
Heating medium leakage • leakage on joints with hot water supply system • leakage in collector	Loss of tightness	Sealing supply system; repairing the heat exchanger
Heat output drop	Temperature of the heating medium differs from the required one Contaminated heat exchanger's surface	Restore the temperature of the heating medium Clean the surface of the heat exchanger

GUARANTEE AND SERVICES

PRESERVE THIS WARRANTY

Type: _____

Serial no.: _____

Date of purchasing: _____

LIMITED GUARANTEE *

The manufacturer guarantee the costumer that the product and its parts are free from material and production failures. During normal use the warranty is 2 years. This warranty concerns the first retail customer.

The guarantee concerns the costs of laboratory investigations and the parts, which are needed for proper operation. The delivery and unforeseeable costs belong also to the mending costs and do not contain compensation costs.

Guarantee mending can only be realized by authorized retailer or service centre.

The guarantee does not concerns the following failures, which are caused by: improper using, damaging, neglect, accident, lack of maintenance, normal attrition, transformation, modification and operation influenceable factor, contaminated fuel, installation of non-suitable part and mending which is done by not authorized retailer or service station.

The regular maintenance is the owner's responsibility.

The manufacturer does not assume the responsibility in case of accidentally happened or directly caused mistake respectively improper using.

***We reserve the right to change of this specification without extra notification. The guarantee can be applied in accordance with above defined. Additional guarantee is not accepted.**

Guarantee servicing

If your appliance needs guarantee service in that case it can be requested at nearest authorized service station giving in the appliance for repairs.

Mending services

Take the appliance to the nearest authorized service station. If the device is not under guarantee the service cost will be invoiced to the costumer at defined price. The service centres are independent from one another and may have different owners. We reserve the right to change of this specification without extra notification. If you would like to contact us the type and serial number of device always be at hand. In case of other needed information write to the distributor.

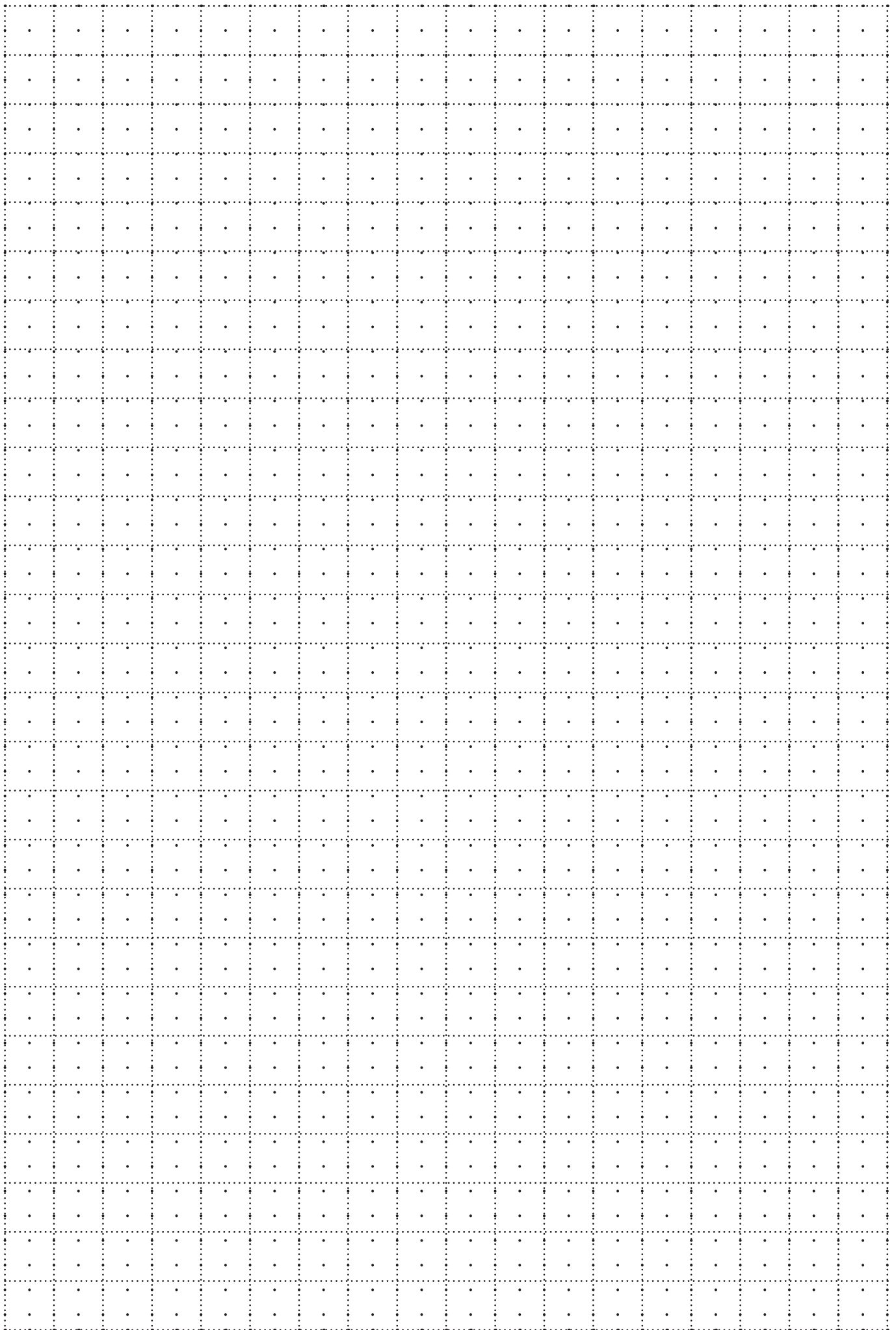



PAKOLE

www.pakole.com

PAKOLE TRADE Kft.

H-8000 Székesfehérvár, Börgöndi út 8-10.

www.pakole.com

mail@pakole.hu

Tel.: +36 22 316 484