



PAKOLE

INSTRUCTIONS FOR INSTALLATION AND SERVICING

for a qualified person

AIR HEATERS BURNING GASEOUS FUELS

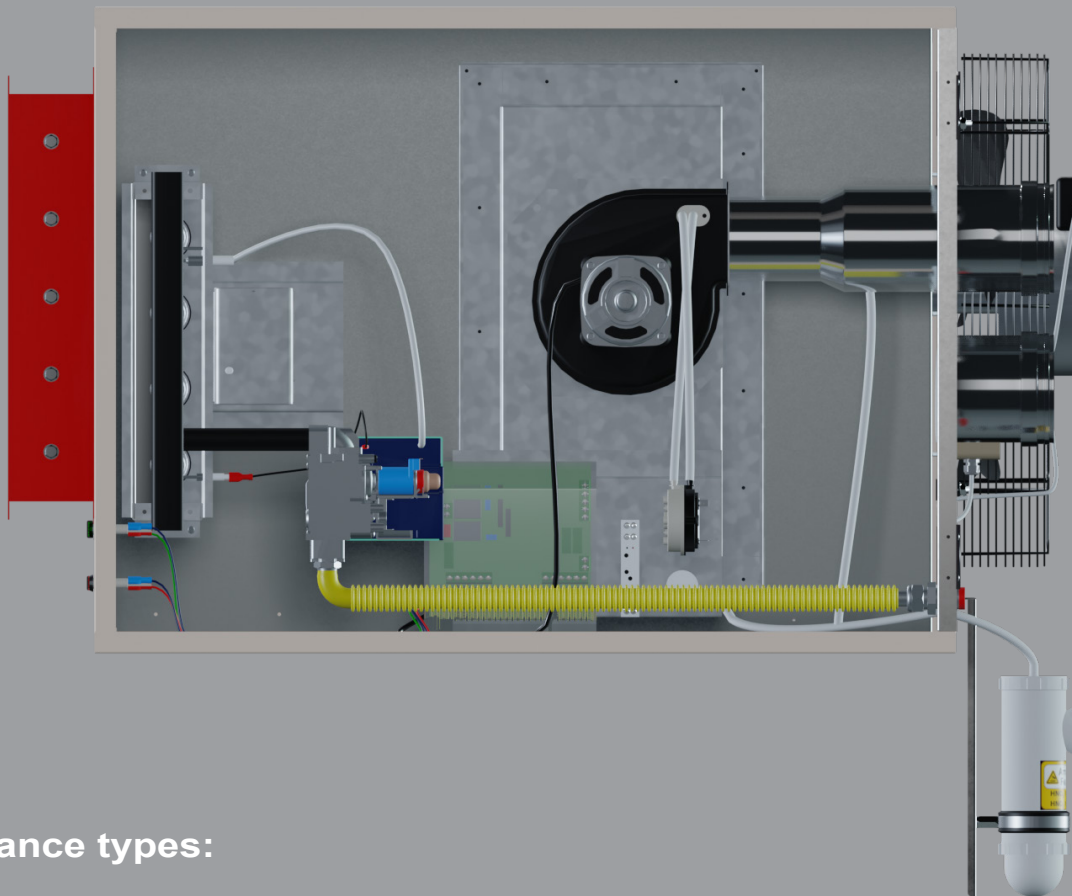

Appliance types:

GTV-CON 27/19A, C, CL

GTV-CON 40/28A, C, CL

GTV-CON 58/40A, C, CL

GTV-CON_008_015-016_003_200304_V002_EN

www.pakole.com

EN

Table of Contents

1. SAFETY INFORMATION	4
2. GENERAL INSTRUCTION.....	5
Installer's responsibilities	5
Data board	5
Corrosive materials	6
Standards and laws	6
Safety signs	6
Safe usage.....	6
3. TRANSPORTATION, UNPACKING, HANDLING	7
4. OPERATION PRINCIPLE	7
Inside structure (controller chamber)	8
Outside structure.....	9
Temperature Controllers	9
Condensate drain.....	10
Appliance types.....	12
5. INSTALLATION	14
Appliance installation	14
Gas connection	14
Electrical connection	15
Connection cable data	15
Electrical connection	16
Electrical connecting specification	18
Optional accessories.....	18
6. APPLIANCE SPECIFICATION	19
Ventilation	19
Protective distances.....	19
7. FIXING AND EXHAUST SYSTEM POSSIBILITIES.....	19
Fixing possibilities	19
Exhaust systems.....	21
Types of exhaust system	21
Minimum distances of the air supply and venting sets.....	24
8. ACCESSORIES.....	25
9. APPLIANCE OPERATION	26
Start, restart	26

10. MAINTENANCE	26
Maintenance procedures	26
Exchange process of narrowing plate (under exhaust fan).....	28
Maintenance of regulation system of appliance.....	28
11. TROUBLESHOOTING.....	29
The appliance does not start.....	29
The appliance operates continuously	29
The appliance just pre-purges	29
The appliance just pre-purges	30
The appliance switches over to safety position.....	30
At starting cold air is flowing	30
The appliance heats insufficiently	30
Increase of values of CO (>200ppm).....	30
12. ENCLOSURES.....	31
Enclosure 1.: Appliance performance data	31
Enclosure 2.: Appliance dimensions	32
Enclosure 3.: Flue longs, allowed pressure drops	33
Enclosure 4.: Gas consumption	33
Enclosure 5.: Target countries/gas categories	34
Enclosure 6.: Eco-Design Declaration of Conformity.....	35
13. GUARANTEE AND SERVICES	37

1. SAFETY INFORMATION



Read and understand this manual thoroughly before installing starting or servicing this equipment. The improper installation or using can cause serious damages! Keep this manual in a safe place in order to obtain information in case of incidental problems!

GENERAL SAFETY NOTICES

Disregard of instructions and notices of this Manual can cause serious bodily injuries or damages as follows: burning, explosion, suffocation, carbon monoxide poisoning, electric shock and in extreme case death!



This appliance can only be used and serviced by such persons who understood and follow the instructions of this Manual.

If you need help or information concerning the appliances – for example installation guide or labels etc. – in that case contact with the manufacturer!

This appliance must not be used by children and mentally or sensitively deficient persons! Take care that the children do not handle it and do not play with devices!



WARNING! Fire, burning, inhalation and explosion hazard! Keep all flammable objects as follows building materials, papers, or carton unites away from heater according to the instructions! Never use this appliance in such rooms where there are flammable volatile materials or the following materials, which can get into the device: petrol, solvent, thinner, fine grained dusty or unknown chemical materials!



WARNING! This appliance can not be used in domestic circumstances or mobile home!



WARNING! For your safety, if you smell gas do the followings:

- **Open windows.**
- **Do not try to light any appliance.**
- **Do not use electrical switches.**
- **Do not use any telephone in your building.**
- **Leave the building.**
- **Immediately call your local gas supplier after leaving the building. Follow the gas supplier's instructions.**
- **If you cannot reach your gas supplier, call the Fire Department.**

The GTV-CON type air heaters burning gaseous fuels appliances have been developed and certified in compliance with EN 1020 standard and qualified for heating of industrial rooms! The function of these heater appliances to ensure heating of appointed workplace temporarily or continuously!

In case of proper using the appliance guarantees safety and energy-saving operation! The combustion products issued during combustion process leave through the flue system into the open air. In case of further possible questions regarding the applicability please turn to the local Fire Protection Office!

Other standards can give you directions in terms of proper using of natural and propane gas as follows: leading/piping, storing etc.! Concerning the detailed content of these standards the local Bureau of Standards can help.



ATTENTION! Processing the condensate:

From NGM decree 11/2013:

The condensate produced in the condensing, gas consuming equipment having max. 70 kW unit heat load and/or in their flue gas exhaust system can be conducted through a water seal without neutralisation, unless the public sewer provider specifies otherwise.

For gas consuming equipment with a heat load exceeding 70 kW the necessity of neutralisation must be discussed with the public sewer provider.

Carbon-monoxide poisoning: The initial symptoms of carbon-monoxide poisoning are similar to influenza namely headache, dizziness and/or nausea! If these symptoms are observed in that case the appliance probably does not work satisfactorily! First of all go fresh air, ventilate the rooms and have the appliance investigated!

Propane-gas: The propane-gas is odourless! Mercaptan-derivative as scented component is mixed into the gas to be able to observe the possible escape! In spite of the typical smell is not felt the propane gas can be present in the environmental air in case of escaping!

2. GENERAL INSTRUCTION

- Make sure that read and understood all the warnings, correct keeping of which can guarantee the safety and faultless operation!
- During the installation be always circumspect! Follow the valid instructions and recommendations!
- The appliance can be operated by specified voltage and frequency marked on its data board! The electrical connections and earthing are prepared as per EN 60335 standard!
- Electrical earthing specification: present appliance is equipped with three points earthing connection in the interests of your protection!
- It needed to ensure the sufficient quantity of combustion air if the appliance is installed without outside air supply!
- Keep away the device from the following strong effects: wind, high pressure water jet, rain or dropping water!
- The appliance must not be used in the open air!
- The application of device is STRICTLY PROHIBITED in such rooms, which are used for sleep or continuous stay!
- Keep away the flammable materials from the appliance and its near environment as follows: fuels, thinner or other flammable fluids and vapours!
- In the interests of avoiding of dust explosion do not used the device in such rooms where the degree of dust concentration is high if the device is installed without outside air supply!
- Before starting of appliance in every case check it in order to detect the possible damages! Never use damaged equipment!
- In case of propane-gas operation never install the device in basement or from that lower being rooms! The propane-gas is heavier specific gravity than the air for this reason in case of possible escaping it will spread towards the lower located rooms!
- Only use that kind of flexible gas pipe and pressure regulator, which is offered for the appliance by the manufacturer!
- Before every starting of heater appliance check the condition of connecting gas hose and if it is particularly worn or damaged in that case exchange it for a new one specified by manufacturer!
- Preserve the equipment in genuine condition, do not leave it to grow old!
- Do not use seriously aged equipment any longer!
- Fix the appliance on such stable surface, which during operation despite warming of appliance preserves its stability!
- If the appliance is put out of use in every case it must be cut off the current and gas!
- Never block the air supply and exhaust pipes!
- Keep away the children and animals from the equipment!
- Never service/mend such devices, which are hot and during operation or electrical charged!
- Never mount such air duct unit on front or back side of device, which is not approved by manufacturer!
- Use exclusively genuine-approved by manufacturer-spare parts, do not install similar quality spare parts for substitution! These kind of substitute parts can cause serious damages concerning the operation of appliance!
- Fix the appliance on such stable surface, which during operation despite warming of appliance preserves its stability!
- If the appliance is put out of use in every case it must be cut off the current and gas!
- Never block the air supply and exhaust pipes!

INSTALLER'S RESPONSIBILITIES

- Making up of gas and electrical connection in compliance with the specifications (it is proposed to connect with the local Building Supervisory Authority or Fire-service),
- installation of equipment in accordance with the definitions of this manual,
- installation according to the fire prevention rules,
- supply of the necessary materials/components for installation(which are not belong to appliance),
- planing of air duct systems (ventilation/connections),
- service execution,
- placing the copy of present manual at owner's disposal,
- assuring of sufficient air circulation around the appliance,
- determination and assuring of needed air for burning, ventilation and blowing in according to the specifications.

DATA BOARD

The appliance is equipped with data board, which is placed on inside of device's door. On this data board there are information concerning the type of device, gas type, electrical connection and flue types.

Manufacturer PAKOLE Trade Kft. 8000 Székesfehérvár, Börgöndi út 8-10.		Type GTV-E-20A-3P		EAC UA,TR,012-10 
Electrical protection: IP20		Nominal input: 21 kW	CE 1008 17	
Electrical connection: AC 230V 50Hz		Pconnecting max.: 60 mbar		PIN: 1008 CQ 2928
Max.current entry: 0,95 A		Jet pressure: 7 mbar	Date/place of production 06.08.2018	
Electrical power: 218,5 W		Pconnecting min.: 20 mbar		
Category: I12H3P		Stat. air pressure: 30 Pa		
Series number: 51-10398-P001		Airflow: 2520 m ³ /h		
		Gas type: Naturalgas		
		Targeted country: GB NOx 4		

CORROSIVE MATERIALS

WARNING! Do not use the appliance in such place where corrosive materials can be in the air! If the appliance has to be applied in this circumstances outside air has to be ensured for combustion air and circulation as well („CL” type)!

The manufacturer can not assume responsibility for fault of equipment in case the installation is not happened according to the above. This responsibility concerns completely the installer. In order to avoid such eventualities, if it is not certain to fit to the building or activity, ask our colleague for help.

Both the owner and the installer have to identify every possible material, which can be present in the building (inflammable materials, corrosive materials, halo hydrocarbons etc.), and with knowledge of these materials must be planned the heater system!

STANDARDS AND LAWS

Every appliance installation must be satisfied the valid laws and standards. These laws refer to the gas and electrical installation respectively the ventilation (special specifications refer to park houses, airplane hangars etc).

SAFETY SIGNS

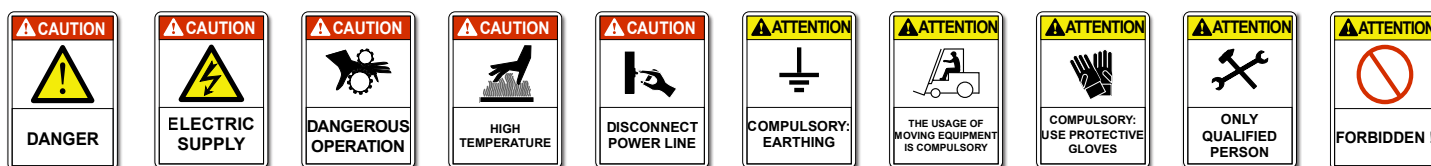

SAFE USAGE

PLEASE OBSERVE THE FOLLOWING RULES DURING INSTALLATION, FIRST SET-UP, USAGE OR MAINTENANCE:

- Installation must be carried out always strictly complying with the current standards of the country where the appliance is going to be used and following, of course, the instructions given by the producer.
- The installation and maintenance operations of the unit can be carried out by qualified and trained personnel only.

Qualified service engineers are those having specific technical experience and/or valid license in the field of heating and cooling installation for home and industry. In any case, call the Manufacturer office or the closest dealer (www.pakole.com) and ask for further informations.

CAUTION DANGER **CAUTION ELECTRIC SUPPLY** **ATTENTION COMPULSORY: EARTHING** **ATTENTION ONLY QUALIFIED PERSON**

- According to the installation project, install the electric power lines.
- Always make sure that the unit and all its electrical parts have been correctly earthed prior starting up the unit.

CAUTION DANGER **ATTENTION ONLY QUALIFIED PERSON** **ATTENTION COMPULSORY: USE PROTECTIVE GLOVES**

- If you have to disassemble the unit, use special protective gloves.
- Beware of sharp edges inside the unit!
- Beware of roof corners of outdoor units!
- Keep suction grids always clear!

CAUTION DANGER **CAUTION DANGEROUS OPERATION** **ATTENTION FORBIDDEN!**

- Before cleaning or maintaining the unit, make sure that all electrical parts have been switched off, the appliance gas supply chain is closed and wait until the appliance cools down. In particular, make sure that the fan is off and cannot be inadvertently started prior to opening inspection panels.
- Fans can reach a speed of 1000 RPM. Do not insert any object nor hands in the electric fan.

CAUTION DANGER **CAUTION ELECTRIC SUPPLY** **CAUTION DISCONNECT POWER LINE** **ATTENTION COMPULSORY: EARTHING**

PLEASE, CHECK THE EARTHED !!

- We recommend to install a safety switch which can be easily reached to cut off the current, near the unit. Before any cleaning and servicing operation, cut off the power line to the unit.
- Before opening the unit, make sure that all electrical parts have been switched off. In particular, make sure that the fan is off and cannot be inadvertently started prior to opening inspection panels.

CAUTION DANGER

- This unit is designed to be used for heating purposes only. Any different use is not allowed as it may be dangerous.
- Should the unit work in a house where disabled people and/or children live, it must be placed safely away from their reach. Always make sure that the access door to the inside control board stay locked.
- An incorrect installation can cause damages to people, animals and property. In case of erroneous installation, the manufacturer cannot be held responsible for such damages.
- **The manufacturer cannot be held responsible for such damages by improper uses, errate uses, etc.**



- Never use the unit to support other equipment.
- Never leave tools, spare parts, etc. inside the unit.
- Make sure that all inspection panels are closed properly.
- Do not expose the unit to inflammable gases.



- In case of breakdown or failure: turn unit off, do not try to repair it on your own, call operator.
- If you are going to leave the heater switched off for a long time, first make sure that in no way this could cause harm to anyone in any way.

3. TRANSPORTATION, UNPACKING, HANDLING

- The delivery must be made according to the following:
 - The package must be carefully secured in the loading space.
 - The package must be transferred in a closed space (always keep packing parts away environmental impacts).
- The unit has a special safety packing for transport and delivery which must be kept in good conditions till the unit is positioned on the installation place.
- Make sure that the unit has all its parts, as specified in the order.
- Check if there are any damages and if the unit abbreviation is the same as the one of the ordered model.
- Every unit is factory tested before shipment, therefore, if there are damages, report them immediately to the carrier.

Transporting, unloading and moving is a process which must be made carefully to avoid any kind of damages. Try not to use the unit's components as hand holds. When lifting, bear in mind that the centre of gravity of the unit may be off-centre.

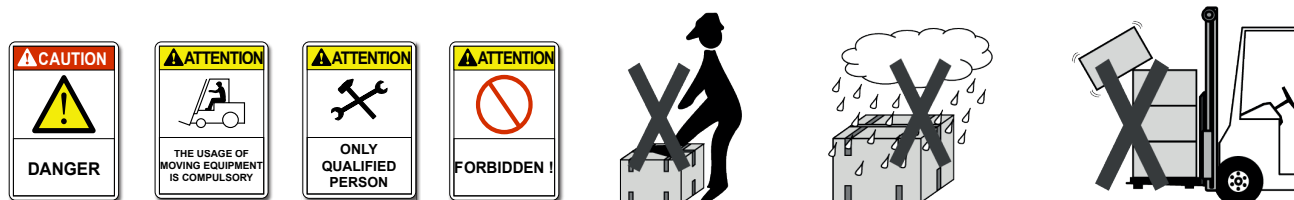

The device is placed in cardboard box, one-way pallets are delivered.

Unpacking process:

- remove the bands from packing of device, the carton box and the covering foil. Screw off the 4 pcs M8x45 fixing bolts on back side of pallet hereby the device can be removed from pallet.
- **do not remove the protection caps from device and gas installing set until the gas attachment**
- investigate the device if it is not damaged during the transportation
- if it is damaged in that case notify the retailer from whom the device was bought!

There is an envelope inside the unit containing the Instructions for Installation and Servicing, User's Manual and Guarantee and services and the warranty documents.

4. OPERATION PRINCIPLE

The equipment operates under the principle of direct heating; this means that the desired temperature value is reached by directly blowing in the heating air into the required room. Beside HEATING (winter) mode of operation the equipment is also able to perform VENTILATION only (summer mode of operation).

Operating principle: the air heater equipment fires the mixture of combustion air and gas (S-, L-, Propane or natural gas) drawn in; the condensing section is after the heating pipe unit. Here the water in steam state condenses and the heat generated during the change of state further increases the overall efficiency of the equipment, and thus produces the heating air which is conducted to the appropriate location (by direct blow-in or through an air duct) which ensures that the temperature of the space to be heated is kept at the desired level, with high efficiency.

The heating and consumption data by equipment type and gas type are included in Annex 4.

The equipment can be supplied with combustion air in two ways:

- directly by drawing in from the space to be heated (A, C types),
- through air ducts with adding external air (CL type). This can be applied in workshops using hazardous substances e.g. painting shop, workshops using explosive and corrosive substances etc.

The air heater type GTV-CON is an equipment with artificial combustion air supply, has several burners (so-called burners in a row), is gas fired, and is suitable for blowing hot air. It can be operated with natural gas, in accordance with the European guidelines concerning gas appliances.

It is typical of the GTV-CON equipment that the gas–primary air mixture is produced in the Venturi burner. The gas-air mixture is lighted by a high frequency electric spark after it leaves the burner. The flame gets into the heat exchanger located in front of the burners in which the flue gas collector fan, installed at the end of the pipes, creates a continuous suction effect. The so-called secondary air, required for perfect combustion, gets into the combustion pipe, oriented by an initial cone, at the air gap between the Venturi burners and the burner stand. The heat generated during the combustion heats up the heat exchanger. The heat absorbed by the heat exchanger is passed on

to the room to be heated, either directly or through an air duct, by a circulating (air ventilating) fan. Shutters take care of directing the blown-off air. The flue gas is passed on to the exteriors through the flue duct by the collecting flue gas fan installed at the ends of the combustion pipes.

At constant nozzle pressure the heat load of the equipment is also constant; if the nozzle pressure is gradually decreased during operation we talk about a modulation apparatus; the rate of modulation can be between 100% and 70%. This alternative can be arranged within the performance limits of 27 kW, 40 kW and 58 kW.

A type 845 Sigma double acting solenoid valve is installed in the equipment. This solenoid valve is suitable for changing the nozzle pressure continuously, i.e. in a modulation form, with a special actuator. In order to achieve perfect combustion the volume of air necessary for combustion must be adjusted according to the rate of changing the nozzle pressure. More air is required for a higher nozzle pressure, and less air for a lower nozzle pressure. In order not to change the gas-air mixing ratio the voltage of the flue gas fan must be reduced to the extent that the air delivered by the flue gas fan is reduced close to the same extent as that of the nozzle pressure.

Additionally the task of the temperature controller is to reduce the nozzle pressure with a current generator in the 40 mA – 145 mA interval, and simultaneously the voltage of the flue gas fan, between 110 – 230 V.

The heating and consumption data by equipment type and gas type are included in Annex 4.

The condensing GTV-CON is an addition to the basic GTV with a condensing pipe section; by installing it we increase the combustion technology efficiency of the apparatus to a value close to 98-99%. In its operation and structure the condensing GTV-CON is identical with the basic GTV.

The combustion product flows to the direction of the flue gas discharge through the pipes of the heat exchanger while heating them up, and in parallel the discharge fan has the drawn in internal or external air flow through the heat exchanger, thus producing the hot air needed for heating (on average 50°C air).

The discharging fan can be supplied by fresh air in two ways:

- by direct suction from the space to be heated (in case of types A, C, CL),
- by the suction of external air (C, CL types).

The hot air that was produced gets into the space to be heated in two ways:

- through guide flaps, blown in directly (in case of types A, C, CL),
- blown in through air ducts, delivered to the desired location (in this case no flaps are installed on the equipment). This is typical of type C and CL GTV-CON. The technical data of the equipment can be found in Annex 1.

INSIDE STRUCTURE (CONTROLLER CHAMBER)

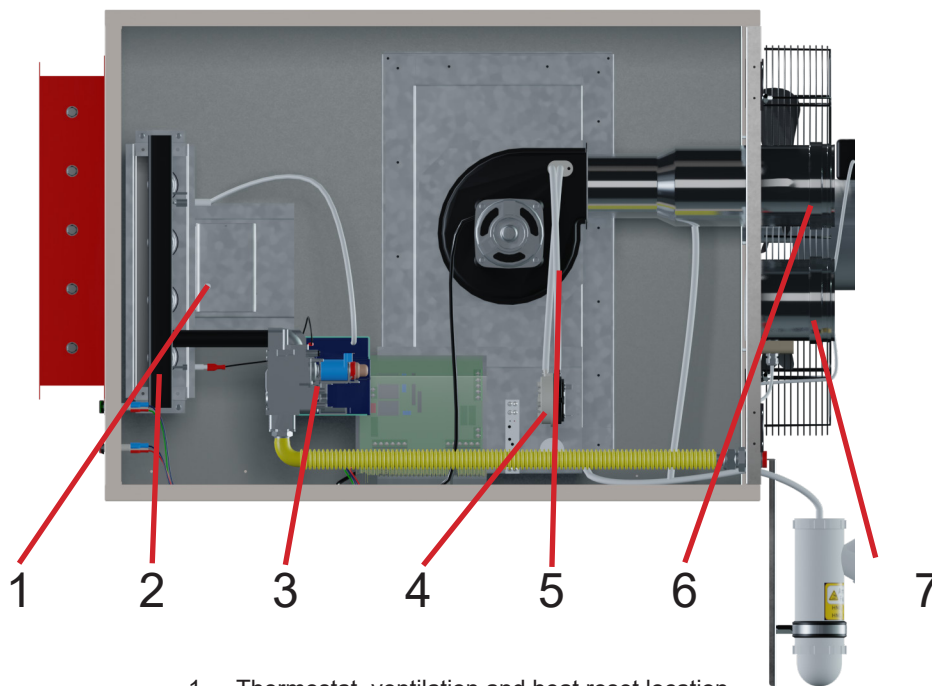

1. Thermostat, ventilation and heat reset location
2. Burning head
3. Solenoid valve and ignition control electronics
4. Air pressure switch
5. Exhaust fan
6. Exhaust outlet
7. Fresh air intake

OUTSIDE STRUCTURE

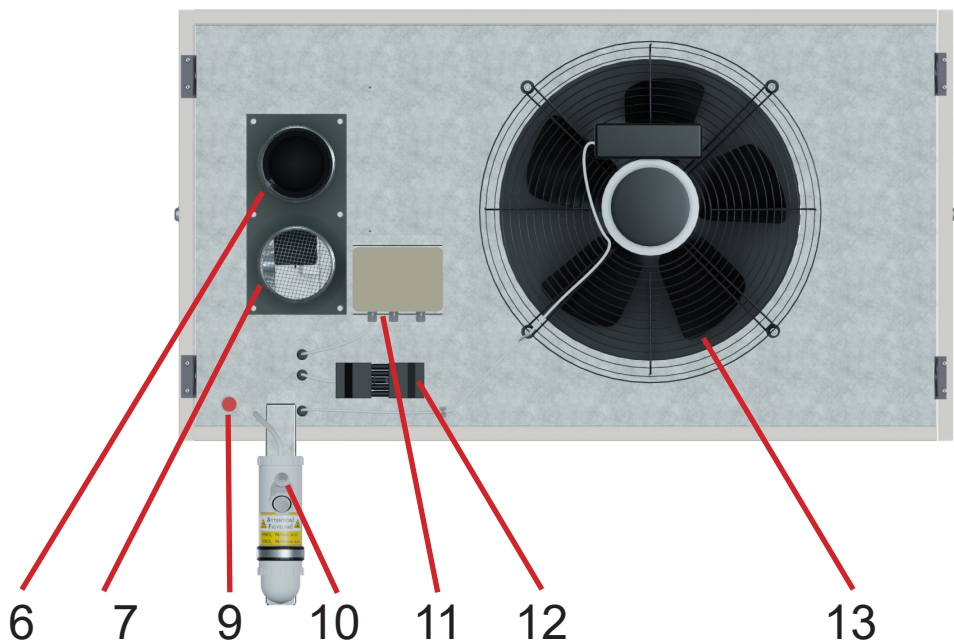

- 6. Exhaust outlet
- 7. Fresh air intake
- 9. Gas connection
- 10. Condensate drainage
- 11. Junction box
- 12. 5 pole connector (unit may be discharged from power by undrawing this)
- 13. Blower fan

3. picture: Outside structure

TEMPERATURE CONTROLLERS

The programming of the regulator type AHP-MOD is included in the machine manual of the regulator and can also be downloaded from our website (www.pakole.com).

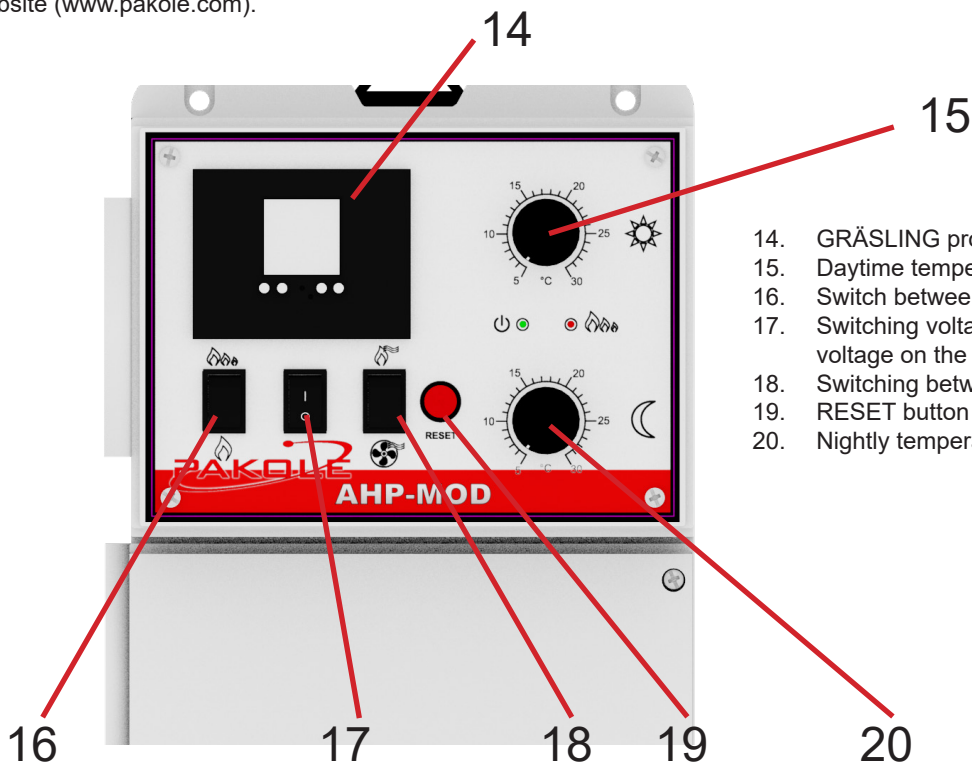

- 14. GRÄSLING programmable clock
- 15. Daytime temperature setting
- 16. Switch between maximum and modulation mode
- 17. Switching voltage on and off (this does not shut off voltage on the equipment!)
- 18. Switching between ventilation and heating
- 19. RESET button
- 20. Nightly temperature setting

4. picture: Temperature Controllers

ATTENTION! The equipment is still live when the regulator is switched off! In order to completely shut off voltage the 5-pole connector [12] in the back of the equipment must be pulled out!

CONDENSATE DRAIN

ATTENTION! Processing the condensate:
From NGM decree 11/2013:



The condensate produced in the condensing, gas consuming equipment having max. 70 kW unit heat load and/or in their flue gas exhaust system can be conducted through a water seal without neutralisation, unless the public sewer provider specifies otherwise.

For gas consuming equipment with a heat load exceeding 70 kW the necessity of neutralisation must be discussed with the public sewer provider.

INSTALLATION OF CONDENSATE DRAIN SIPHON



WARNING! Before commissioning the equipment it is mandatory – as a first step – to install the condensed water discharge siphon!



ATTENTION! AFTER INSTALLATION THE SIPHON MUST BE FILLED WITH WATER, OTHERWISE AN AIR PLUG IS CREATED THAT WOULD PREVENT THE DISCHARGE OF THE CONDENSATE AND THE EQUIPMENT REPORTS FAILURE!

The place of the bore-holes of the siphon holder plate

screwing on with the attached self-tapping screws

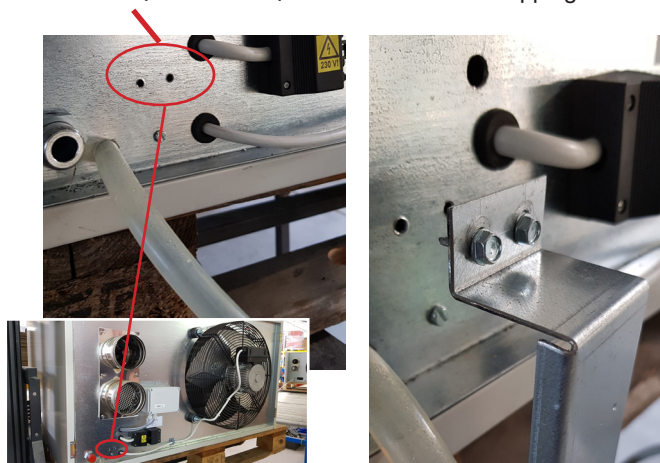

setting up the correct internal silicone pipe length

INCORRECT internal silicone pipe length

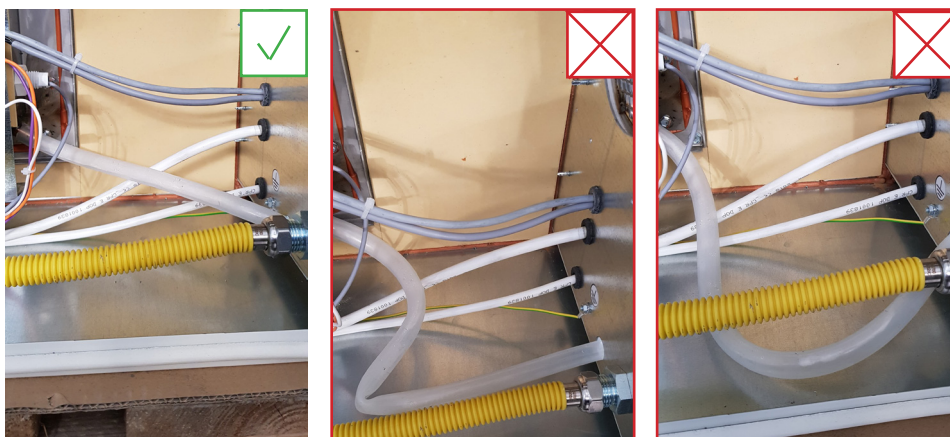

Cutting the silicone pipe to size



INCORRECT external silicone pipe length



Location where the condensate discharges and of condensate drain off as required

5. picture: Installation of condensate drain siphon

APPLIANCE TYPES

The overall dimension of appliances are in enclosure 2.

AXIAL FAN-TYPE EXECUTION (GTV-CON-...A)

Features:

- suction in of heater air is executed from the heated place, it can not be connected to air duct
- blowing in of warm air is executed directly through the air leading lamellas

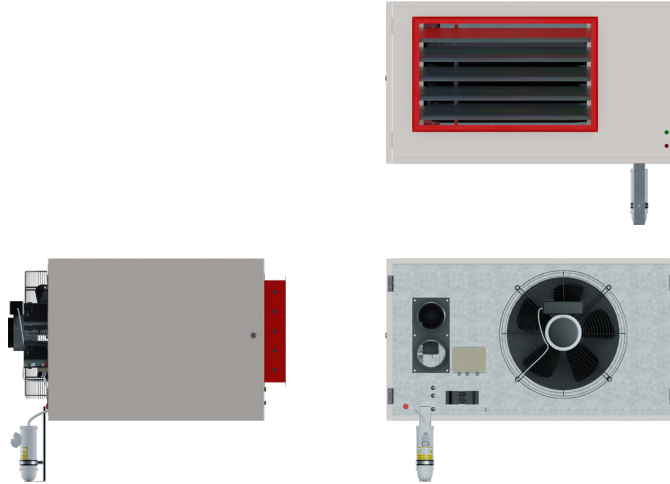

6. picture: Axial fan-type warm air blower

CENTRIFUGAL FAN-TYPE EXECUTION (GTV-CON-...C)

Features:

- suction in of heater air is executed from the heated place,
- blowing in of warm air is executed directly through the air leading lamellas or through the attached air duct to the demanded places

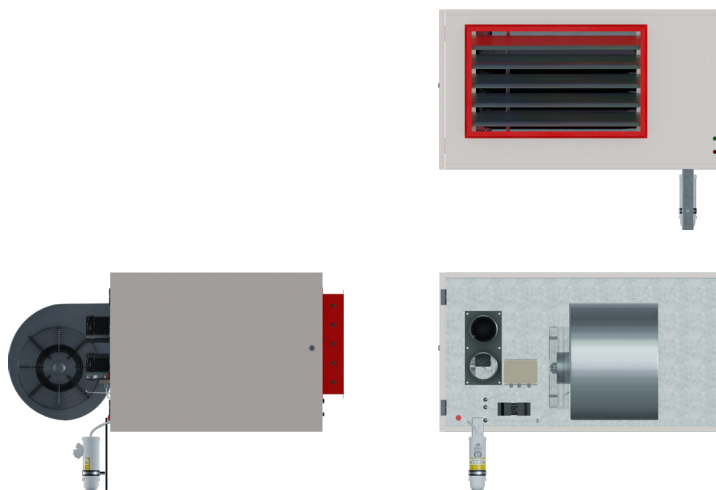

7. picture: Centrifugal fan-type with lamella execution

CENTRIFUGAL FAN-TYPE EXECUTION (GTV-CON-...CL)

Features:

- suction in of heater air can be from inside or outside respectively in case of installed „winter-summer” mode relay the suction- ing of mixed inside-outside air is executed through air duct,
- blowing in of warm air is executed through the attached air duct system to the demanded places.



8. picture: Centrifugal fan-type with air duct execution

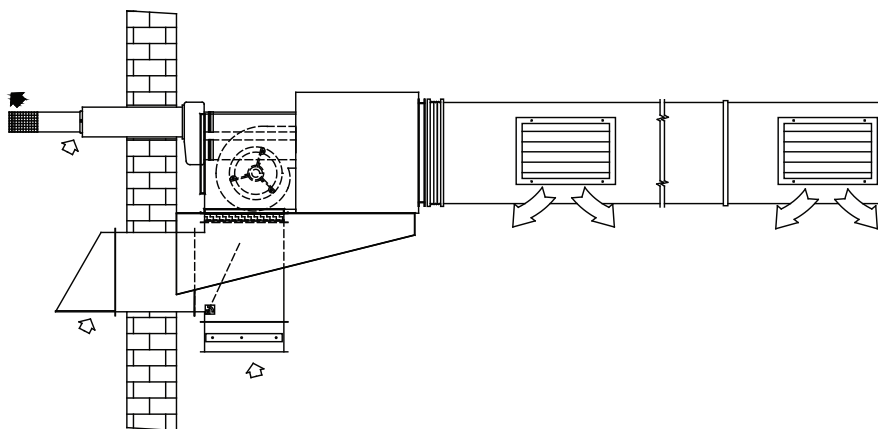

9. picture: Air duct execution at „CL” type

5. INSTALLATION

APPLIANCE INSTALLATION

- **SOLELY INTERIOR** installation is possible,
- for the sake of appropriate efficiency the position and the high of installation has to be carefully defined,
- the mounting of appliance can be executed by cantilever respectively suspension,
- the appliance has to be placed in that way that its every part be accessible.

GAS CONNECTION

WARNING! The appliance can only be operated by gas defined on the data board of appliance!

The nominal values of gas-supply pressure:

- **in case of natural gas: 30 mbar (min. 20 mbar – max. 60 mbar)**

The allowed maximum pressure of gas-supply: 60 mbar!

WARNING! If the pressure of gas-supply is higher than 60 mbar in that case the using of pressure regulator is indispensable because the max. allowed pressure of double-closed magnetic valve is: $P_{max} = 60\text{mbar}$

The pressure regulator can be installed before each appliance or centrally namely one piece into the gas-supply pipe. In case of unique solution - namely there is pressure regulator before each appliance – before every pressure regulator, in case of centrally mounted pressure regulator before pressure regulator and each appliance **MUST BE INSTALLED GAS FILTER** to be able to avoid the blocking of appliance's gas magnetic valves, which can be caused by possible contamination settled in the supply pipes (despite blowing out of pipes it can be present).

The connection to the gas-supply pipe must be from above or side (Pic. 10) because in case of bottom connection the possible contaminations settled on the pipe can influence the proper operation of equipment.

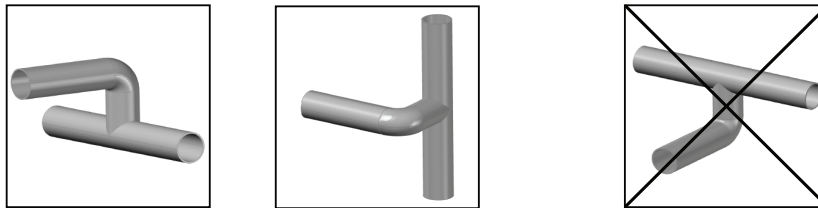

Appropriate connection

Incorrect connection

10. picture: Connection to gas-supply pipe

The gas connection must be accomplished by flexible gas pipe. Use such flexible gas pipe for connection, which renders 100 mm free moving possible. The flexible gas pipe must be mounted free from torsion! Recommended to apply gas connection set (flexible gas pipe, gas filter, 1/2" shut off valve) marketed by PAKOLE Ltd. (Pic. 11). If there is installed pressure regulator per appliance then it must be mounted between the gas filter and flexible gas pipe.

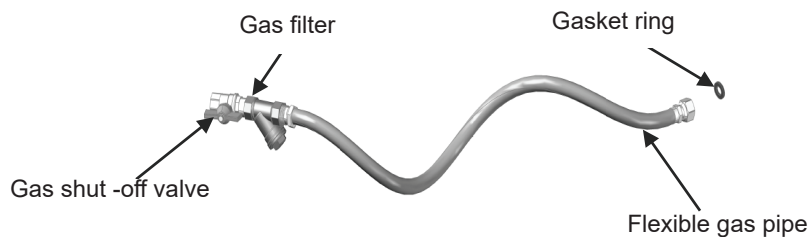

11. picture: Attachment with flexible gas pipe

Attachment of flexible gas pipe has to be directly to the outside threaded gas connection of appliance located on the back side of it.

PERFORMANCE RANGE (kW)	CONNECTING DIMENSION (Inch)
27/19, 40/28, 58/40	1/2"

Works to be performed during gas connection

- Gas pipes clearing

The thorough clearing of gas-supply system is very important before attachment of appliance.

- Gas leakage checking

After installation, of appliance make sure about leak-proof mounting of connections. This action must be fulfilled after every dismantling and assembling!

ELECTRICAL CONNECTION



ATTENTION! Both the fan and the ignition control needs 230V/50Hz mains voltage. Before connecting the appliance to the gas pipe line, please disconnect it from the power line and close the gas valve front of the burner. The appliance must be connected to a earthed power supply system! If the above instructions are not followed that can lead to death, heavy injuries or property damages!

CAUTION



DANGER

CAUTION



ELECTRIC SUPPLY

ATTENTION



COMPULSORY: EARTHING



PLEASE CHECK THE EARTHED!

- The suitable safe operation can not be performed, unless all safety regulations are kept and the equipment properly earthed.
- Whenever an electrical connection is made always the earthing wire should be the longest even in case of cable over stretching the earthing should brake last.

CONNECTION CABLE DATA

- Choosing the right size of cable the maximum amperage, the local regulations and the fact that more than 3% voltage drop is not allowed need to be taken into account.
- Use H05V-K or N07V-K insulated cable suitable for 300/500V.
- All cables need to be lied into a wire tube or channel.
- Cables coming out from the wire tube or channel should not be in tension or twisted. Cables always need to be protected from the humidity. Left cables must only be used for connecting the end section. Check all cable connections.

ELECTRICAL CONNECTION

REGULATION : MODULATION: ON (100%) - Mod (100%...50%) - OFF

- Connect the heater electrically according to the attached drawing.

! Electrical connection scheme might be changing: we do recommend using the electrical wiring scheme sent with the product.

GTV CON...A,C,CL (AXIAL / CENTRIFUGAL FAN-TYPE) ELECTRICAL CONNECTION OF MODULATION REGULATION APPLIANCE WITH SIT CONTROL BOX AND 5 POLE PLUG

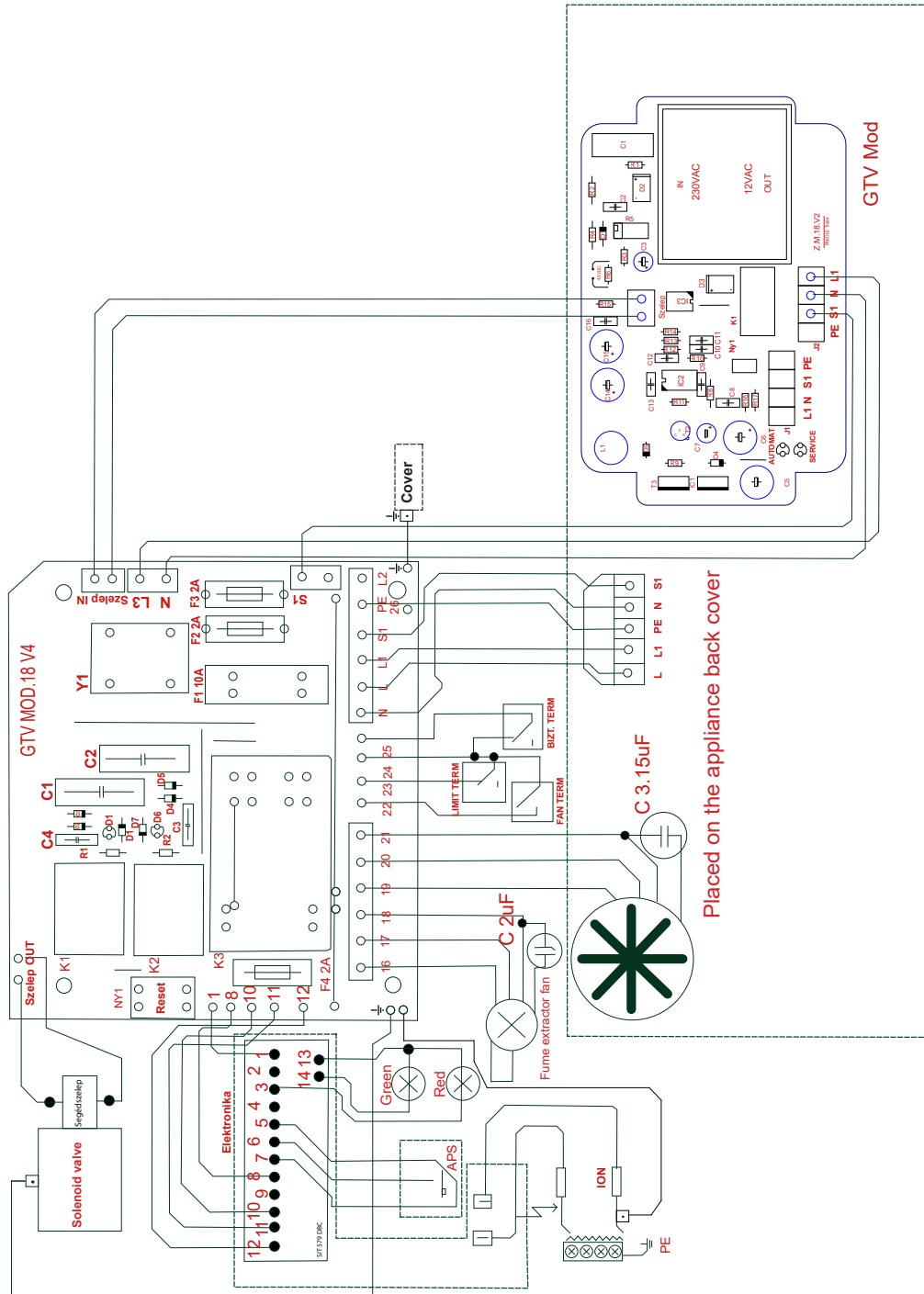

12. picture: Modulation regulation ,Axial fan-type electrical connection of GTV-CON appliance with SIT control box

ELECTRICAL CONNECTION OF AHP-MOD REGULATOR

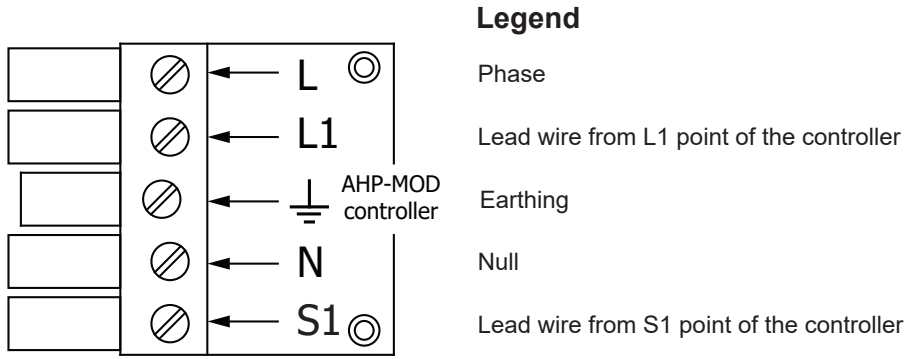
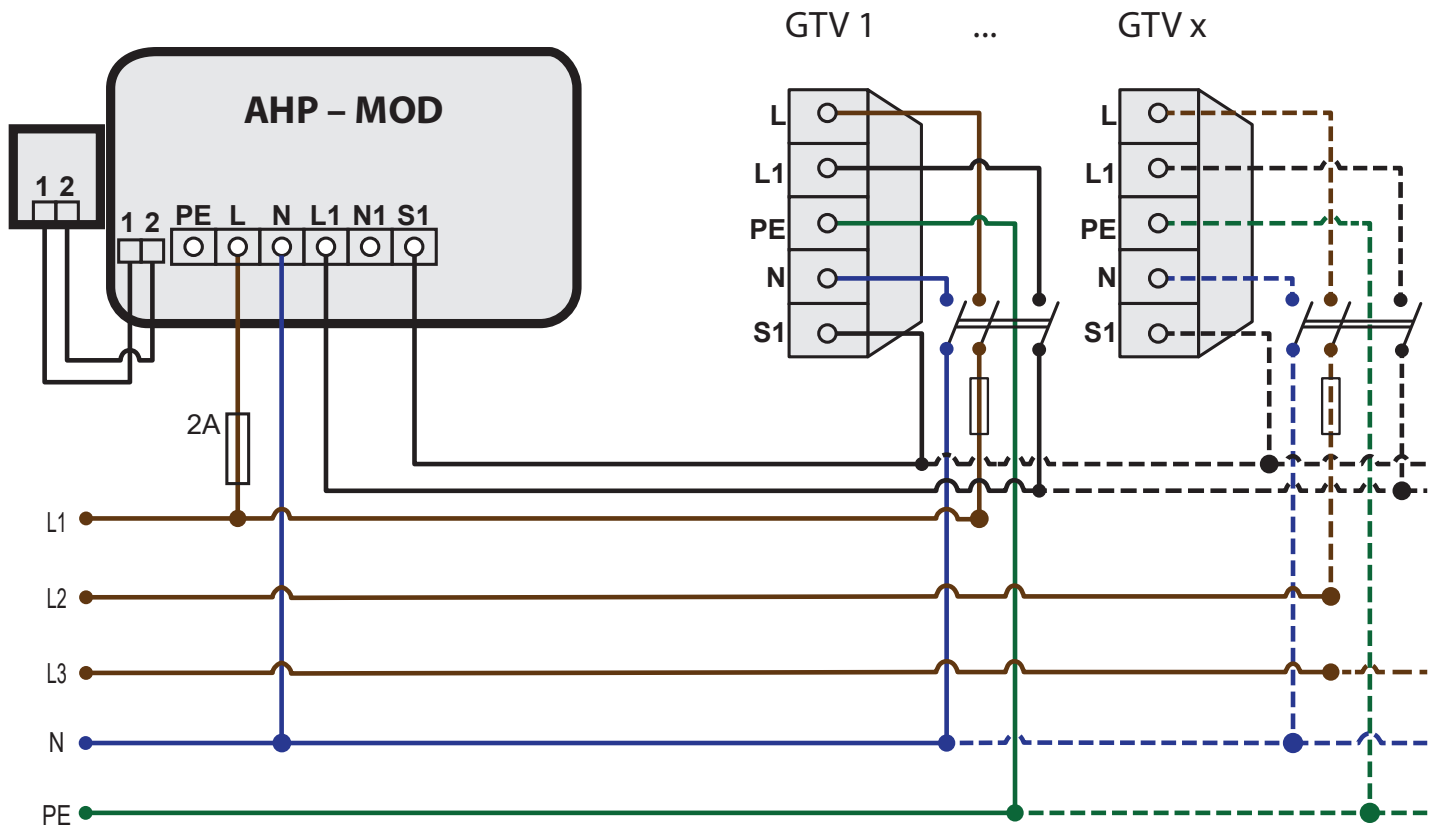

13. picture: Possible regulation mode controlled by AHP-MOD type thermostat

The cross-section of the connecting electric cable should be at least 1.5 mm, and the material copper: type HOV5VV-F 4 x 1.5 mm²

ELECTRICAL CONNECTING SPECIFICATION

- The mains fuse should be inactive characteristics-type and for definition of its value take the nominal current consumption - indicated on the data board - of device respectively the quantity of devices moreover in case of bigger distances the length of mains wiring into account.
- The mains wire must be installed in the fixed way.(The appliance can not be attached to the mains by plug!)
- The proper installation of phase-null wires have to be thoroughly checked!
- The appliance has I-class protection against electric shock for this reason it must be supplied with wired protection against electric shock!
- The appliance must be operated under dry circumstances.
- At electrical installation of appliance the relevant standard must be considered.
- For the sake of suitable detachability of appliance from the electrical supply, double-poles – phase / null switching off – detaching main-switch must be installed.
- This main switch must be lockable-type in „OFF” position (e.g. by padlock).
- In case of specification of the main switch, the nominal current consumption of appliance moreover the instruction of 2014/35/EU must be considered.

OPTIONAL ACCESSORIES

MODULATION CONTROLLERS AND TEMPERATURE



14. picture: AHP-MOD type controller and temperature sensor

AHP-MOD

The controller has the following settings: HEATING / 0 / VENTILATION; there is a RESET button and a switch that changes between MODULATION and the double-point control, and there is also a program clock. The daytime and the night temperature can be set by two knobs. The programmable thermostat switches on the appliance depending on the time of the day and the temperature we want to have in the room.

Setting: In heating mode the equipment operates at 100% when the knob is set to 30°C and maintains this for 30 seconds. Set the solenoid valve to peak pressure. After the 30 seconds have elapsed, turn the knob until the red light starts flashing. Then measure the voltage between points S1 and L1, which has to be between 120 V and 125 V at minimum power; if there is a deviation you can set the value with the potentiometer. After that set the minimum pressure value on the solenoid valve. Finally set the desired temperature.

This type of control is the so-called PILOT control where the communication between the program clock and the hot air appliance(s) takes place only through 1 wire, the „control wire”. The signals coming from the temperature regulator are received and processed by a control electronics (signal processing) unit and it starts the program accordingly.

6. APPLIANCE SPECIFICATION

VENTILATION

The appliance operates either using of inside air or outside air respectively inside-outside mixed air, which can be sucked in through of located air duct system.

If the appliance uses indoor air than need replace the air by ventilation.

PROTECTIVE DISTANCES

From flammable materials it is obligatory to keep **SAFETY OF OPERATION** and **FIRE PREVENTION** distances!

MINIMAL DIMENSIONS OF PROTECTIVE DISTANCES:

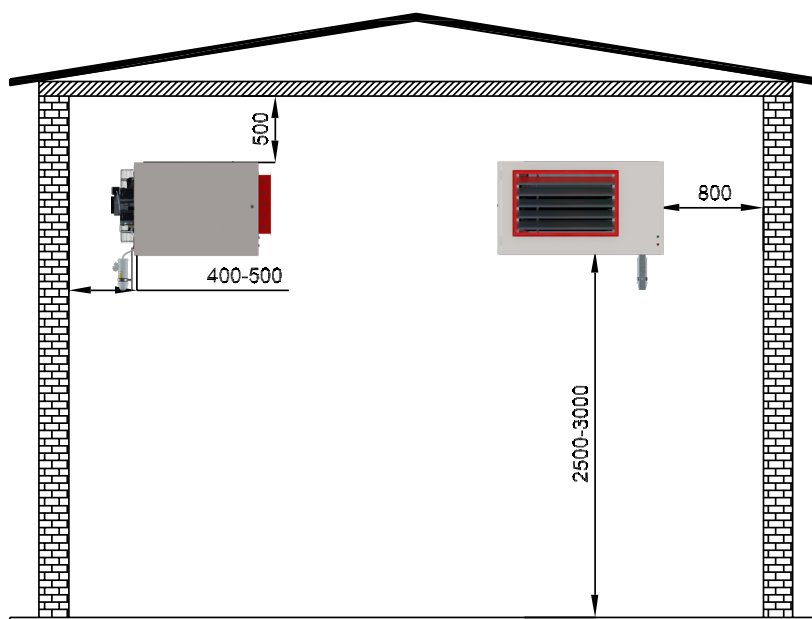

15. picture: Protective distances

7. FIXING AND EXHAUST SYSTEM POSSIBILITIES

FIXING POSSIBILITIES

LOCATION ON CANTILEVER

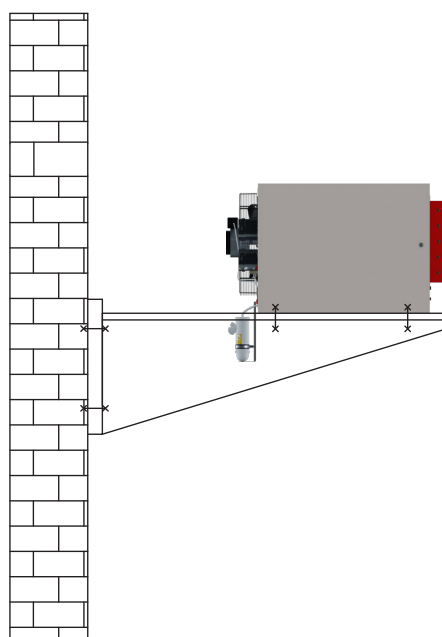

Located on cantilever

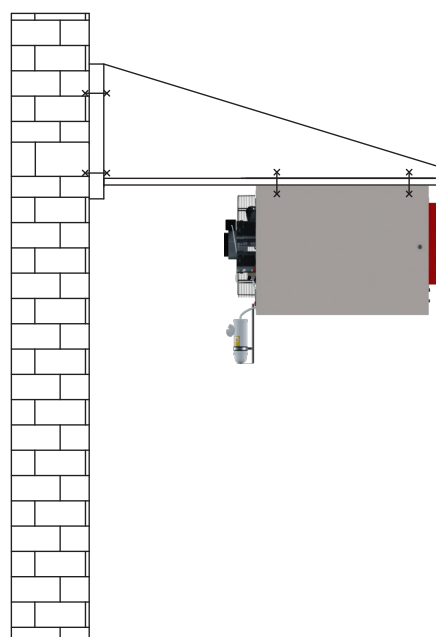

Suspended installation

16. picture: Fixing possibilities

CANTILEVER DIMENSIONS

(The cantilever can be purchased from the manufacturer for installation.)

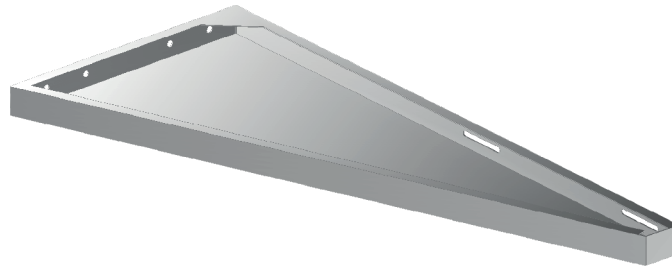

17./a picture: Cantilever

CANTILEVER DIMENSIONS AT GTV-CON 58KW APPLIANCES:

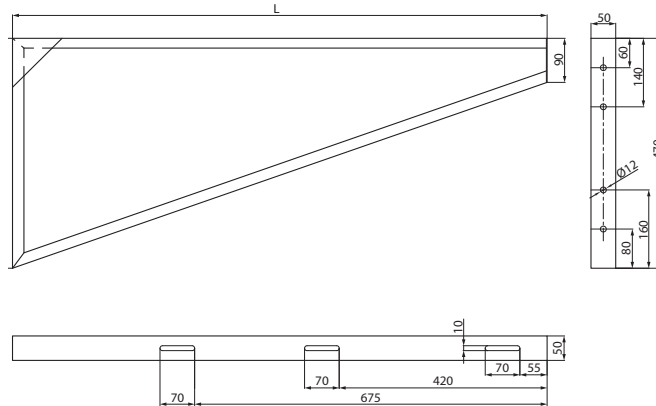

Type	L
GTV-CON A, C, CL	1250 mm

17./b. picture: Cantilever

CANTILEVER FIXING POINTS (GTV-CON-20....58KW)

⚠ ATTENTION! In order to ensure flow away of the condensate produced, at least 1° inclination must be provided for the apparatus in the direction of the control chamber!

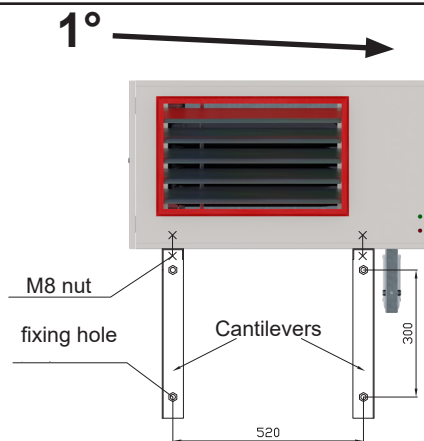

18. picture: Anchorage points

The cantilever can be mounted to the wall by its fixing points. (4 pcs/pair)

Take the following into consideration:

- in case of appliance power up to **max. 58kW** the proposed mounting solution is the using of tightening-wall plug type **M10/100** for cantilever fixing

The appliance can be mounted on the fixed cantilevers by lengthwise grooves. These grooves make the suitable fixing possible ensuring the minimum fire protection distances.

The fixing of appliance to the cantilever can be executed by 4 pcs **M8x25 5.6** screws or M8 threaded rod.

There are 4-4 pcs riveted M8 nut on top and bottom side of device.

⚠ WARNING! During the installation of appliance lockwasher has to be mounted under locknuts, threaded rod and screws!

EXHAUST SYSTEMS

EXHAUST SYSTEM UNITS



1. Perpendicular roof exit (flue/combustion air) set C32K
2. Side-wall exit (flue/combustion air) set C12K
3. Straight unit, 250/500/1000 mm
4. 90° elbow
5. B23 set for flat roof or side-wall exit
6. Flue end unit B23/C12K
7. Combustion air sucking end unit C12K
8. Rubber bell (for slanting roof B23)

19. picture: Exhaust system units

The appliances can only be installed by such dimensions and material of combustion air supply and flue systems, which are specified by appliance manufacturer.

The allowable flue lengths and pressure drops can be found in the **enclosure 3**.

TYPES OF EXHAUST SYSTEM

B22H TYPE

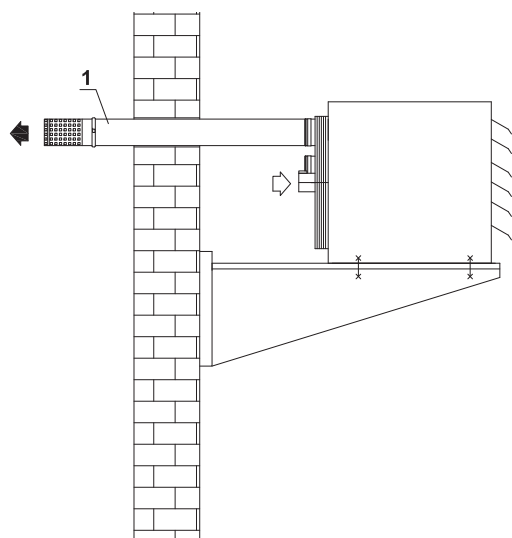

The combustion air supply is directly from the heated area and flue system $\varnothing 100$ mm is horizontally across the wall to outside.

Components:

- horizontal flue terminal
- clamp
- flue pipe 1 m

It is possible to extend the flue pipe with the following components:

- clamp
- flue pipe 250/500/1000 mm length ($\varnothing 100$ mm)

The flue pipe is not insulated for this reason during installation insulation has to be placed around the pipe between the pipe and wall!

20. picture: B22H type horizontal execution

B22V TYPE

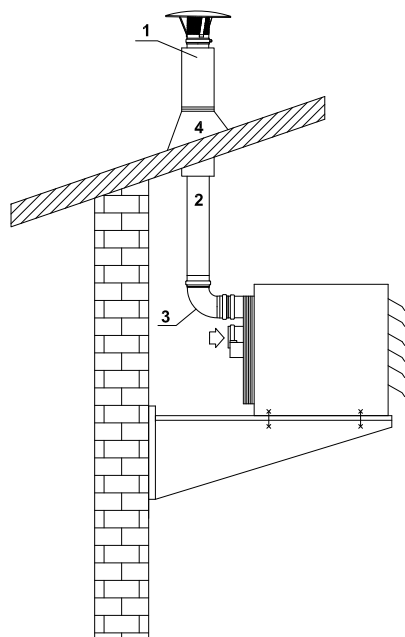

21. picture: B22V type vertical appliances

The combustion air supply is directly from the heated area and the flue system Ø100 mm is vertically across the roof to outside. The outside flue pipe is insulated Ø150/100 mm.

Components:

- vertical flue roof terminal,
- flue pipe 250/500/1000 mm (Ø100 mm),
- elbow 90° (Ø100 mm),
- rubber sealing

It is possible to extend the flue pipe with the following components:

- clamp,
- flue pipe 250/500/1000 mm length (Ø100 mm)

C12 K TYPE COAXIAL

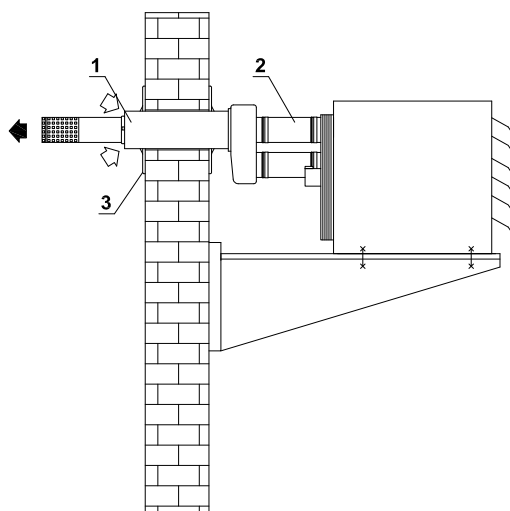

22. picture: Coaxial C12 type appliances

The combustion air supply and flue system is horizontally-coaxial solution-across the wall to outside.

Components:

- horizontal wall terminal (fume/air coaxial pipe)
- flue pipe 250/500/1000 mm length (Ø100 mm)
outlet diameters: Ø100/150 mm

The pipes can be extended or shorted with different components. The coaxial terminal can be removed from the appliance with pipes: 250/500/1000 mm length and clamps.

C12 TYPE

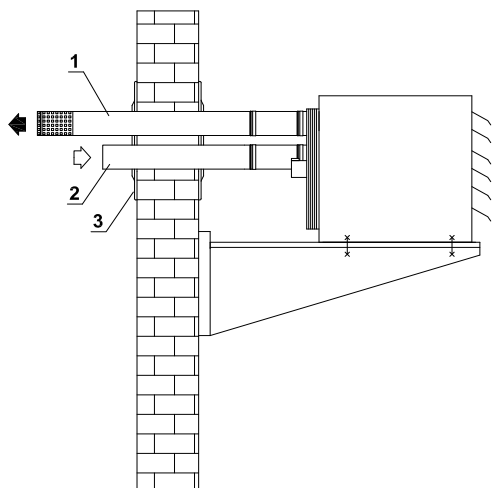

23. picture: C12 type horizontal appliances

The combustion air and flue system is horizontally across the wall to outside

Components:

- flue pipe: 250/500/1000 mm (Ø100 mm),
- air supply pipe: 250/500/1000 mm (Ø100 mm),
- cover (optional)

The pipes can be extended or shorted with different components

- pipes 250/500/1000 mm length
- clamps

C32 TYPE

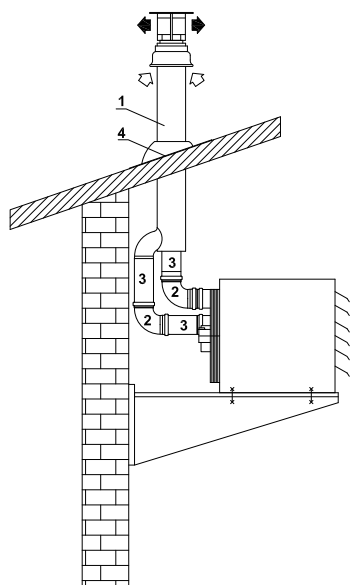

24 picture: C32K type vertical appliances

The combustion air supply and flue system is vertically coaxial solution, across the roof to the outside.

Components:

- vertical roof terminal (fume/air coaxial pipe)
- elbow 90°(Ø100 mm)
- straight line pipe
- 250/500/1000 mm (Ø100 mm)
- rubber sealing (straight or slanting)

The pipe diam. above the roof 100/150 mm

The pipes can be extended or shorted with different components.

The coaxial terminal can be removed from the appliance with pipes: 250/500/1000 mm length and clamps.

C52 TYPE

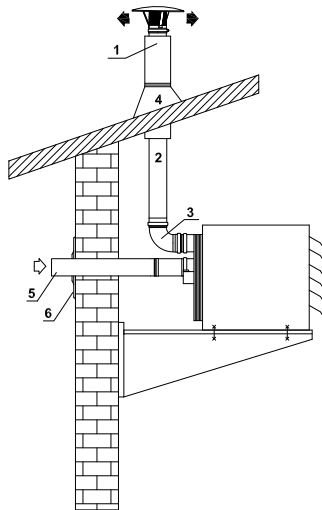

The combustion air supply is across the wall from outside, the flue system is vertically across the roof to outside with 100 mm pipe. The pipe diam. above the roof is 150/100 mm.

Components:

- vertical roof terminal
- flue pipe 250/500/1000 mm (Ø100 mm)
- elbow 90° (Ø100 mm)
- rubber sealing
- air supply pipe 250/500/1000 mm (Ø150 mm)
- cover grid

The pipes can be extended or shorted with different components:

- pipes 250/500/1000 mm (Ø100 mm)
- clamps

25. picture: C52-type execution

MINIMUM DISTANCES OF THE AIR SUPPLY AND VENTING SETS

THE COMBUSTION AIR SUPPLY AND FLUE SYSTEM IS VERTICALLY-COAXIAL SOLUTION- ACROSS THE ROOF TO THE OUTSIDE AT B22 TYPE.

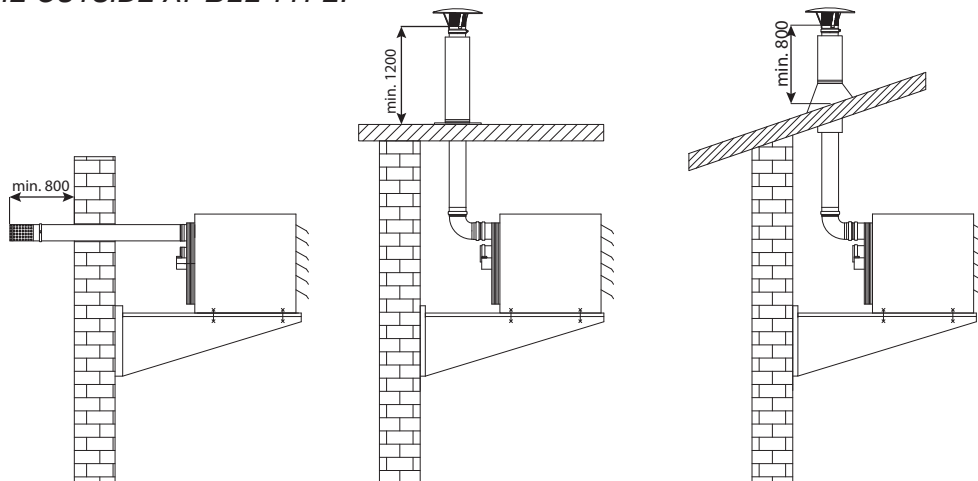

26. picture: Minimum distances for B22 type

THE MINIMUM DISTANCES OF THE FLUE AND AIR SUPPLY SYSTEM FROM THE WALL FOR C12 AND C12K TYPE

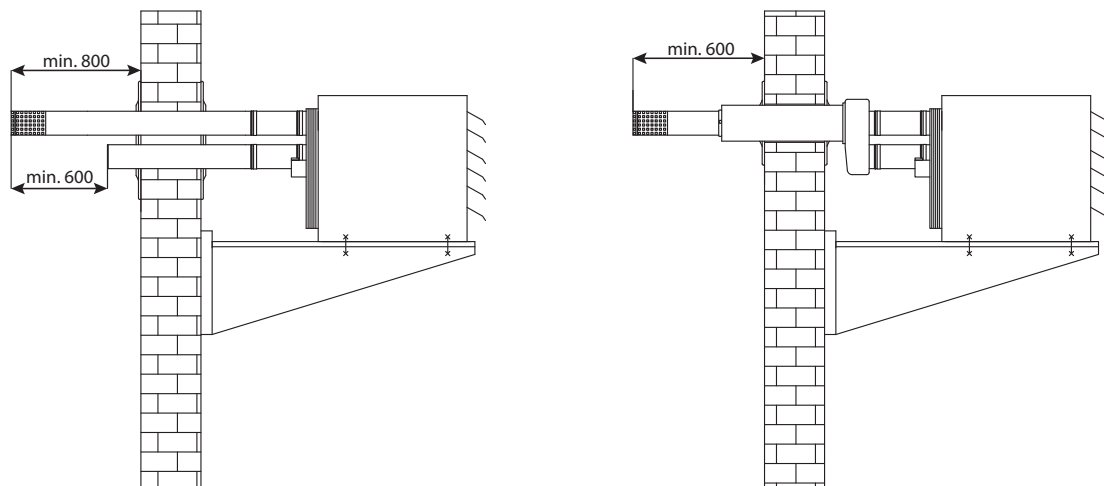

27. picture: Minimum distances for C12K type

THE MINIMUM DISTANCES OF THE FLUE AND AIR SUPPLY SYSTEM FROM THE ROOF FOR C32 AND C52 TYPES

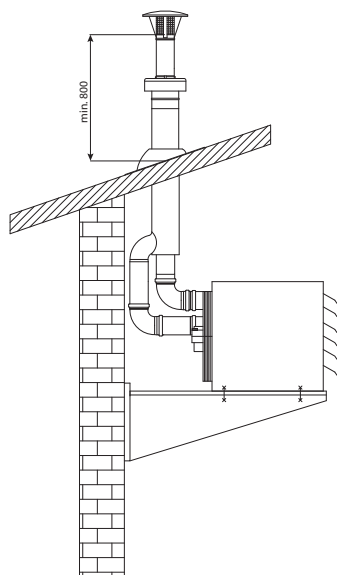

28. picture: Minimum distances for C32 type

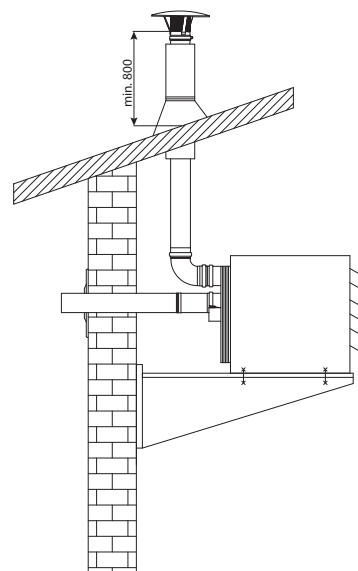

29. picture: Minimum distances for C52 type

8. ACCESSORIES

These components are optional accessories of **GTV-CON-...CL** type appliances according to the Pic. 30. If you would like to purchase these air duct components, please contact with sales section of **PAKOLE TRADE Ltd.**

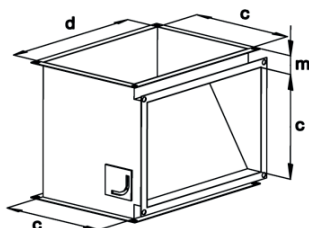

T form with „winter-summer“ mode relay (TIK...)

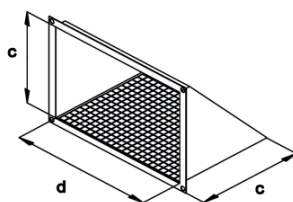

Outside air sucking form with bird protector grid (KLM...)

Type	Marking (mm)			
	a	b	c	d
GTV-CON 27/19A	350	600	350	500
GTV-CON 40/28A	500	600	400	550
GTV-CON 58/40A	650	600	450	600

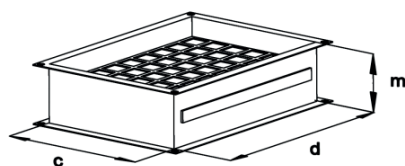

Filter keeping with filter (SZTS...)

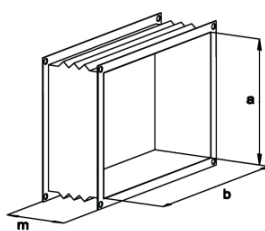

Vibration damper (RT...)

Type	Marking (mm)
	m
TIK...	50
KLM...	-
SZTS...	150
RT...	160
TCS...	a
AEL...	500

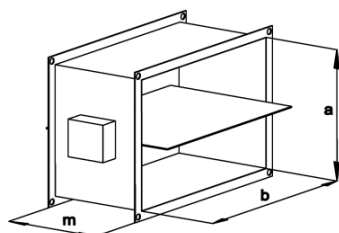

Fire damper (TCS...)

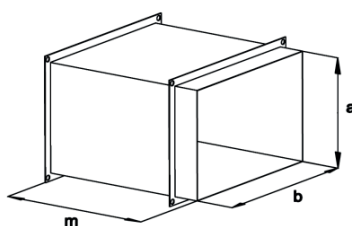

Adjustable straight air channel section (AEL...)

30. picture: Air duct components

9. APPLIANCE OPERATION

START, RESTART

The properly installed appliance according to the control sign received from temperature regulator - in the present case heating – starts the exhaust fan, which executes the 30 seconds pre-purge time. This time period is also enough for biggest power appliance to ensure the satisfactory air exchange namely the triple of combustion air volume. When the ventilation happened the sparking is started and the dual magnetic valves are opened the gas ignites.

If the continuous burning is formed within 5-10 seconds the appliance is operating normally the green control lamp is lighting. During operation the appliance continuously monitors the status/sign of differential pressure switch and flame detector, if needed the electronic control intervenes in the process.

If the status of differential air pressure switch is changed during operation namely switches over from work/switched on position to basic/standstill position in that case the automatic electronic control stops the gas supply by closing of magnetic valves and controls the appliance in error mode moreover the red control lamp located on front side of device is lighting.

In case the flame detector of automatic burner control does not sense flame formation during ignition in that case stops the gas supply and controls the appliance in error mode moreover the red control lamp is lighting.

In case during burning process the pressure difference decreases under the permissible minimal value on the air pressure switch than the automatic control prohibits the operation as follows:

- stops the gas supply,
- stops the operation of exhaust fan,
- controls the appliance in error mode and red control lamp is lighting.

 **ATTENTION! The restart of appliance, which is in safety status can only be possible by pushing of „RESET” push button located on the PCB (inside of appliance) or on the temperature regulator!**

General information: The flame detector is self-checking and can just operate with the burner, other environmental effects (ambient temperature, lights) can not influence it.

 **ATTENTION! If the heater appliance is working, than it is prohibited to close the shutters completely!**

10. MAINTENANCE

The GTV-CON type warm air blowers apart from the checking of suspension and cleaning of cover, lamellas and circulating fan do not need extra maintenances but to be able to preserve the long lifetime of appliance it is recommended to have yearly supervision done with a qualified service or expert.

MAINTENANCE PROCEDURES

Maintenance supervisions by the costumer: (recommended half a yearly)

- supervision of circulating fan, if needed clean it (by high pressure air),
- supervision of outblowing apertures (lamellas)
- supervision of suspension points/surfaces by survey
- supervision of the condensate discharge siphon and the silicone pipes, regular cleaning.

 **WARNING! Before every maintenance the appliance must be detached from the electrical supply by switching off the main-switch and disconnecting the connection plug located on the back side of appliance!**

 **ATTENTION! In case operational circumstances of appliance (atmosphere is contaminated with corrosive substances, dirt) need it, then supervision and cleaning may have done more often! The main reason of this that dirt placed on the fan may damage efficiency of appliance!**

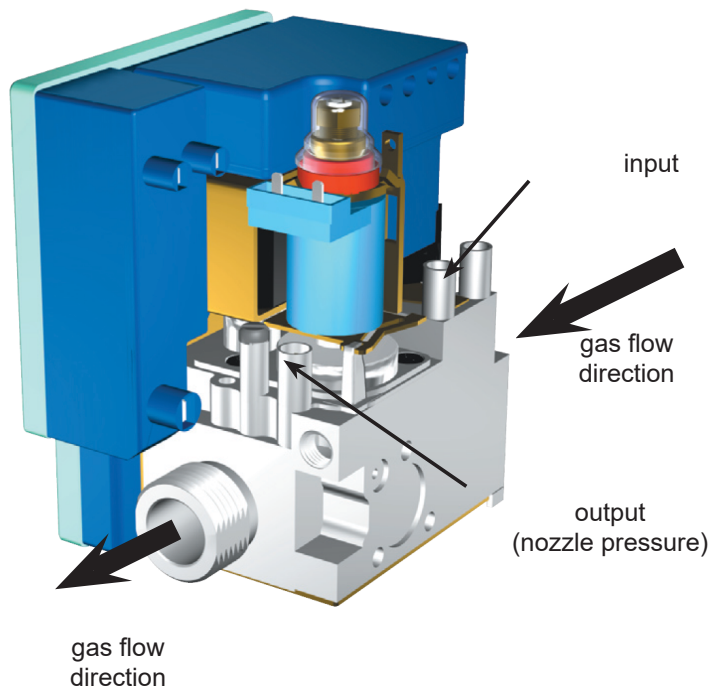

31. picture: Gas pressure check on SIT solenoid valve

MAINTENANCE SUPERVISION SOLELY BY A QUALIFIED SERVICE DEPARTMENT

(all kinds of interventions for which disassembly of appliance is necessary):

- check of the condition of pressure regulator
- check of the protective earthing
- check of the electrical connection
- check of the exhaust fan and circulating fan: check the free rotation of fan and remove the possible contaminations from the impellers
- supervision of the heat exchanger
- supervision of working of the temperature controller
- check of the ignition and ionization electrode, if necessary change it
- check of the exhaust fan and circulating fan, if necessary clean those
- supervision of the quality of combustion
- dismounting and clean of the gas filter by high pressure air



ATTENTION! After every maintenance the appliance must be again adjusted !

Constructional components, which ensure the suitable operation:

- double-closed solenoid valve
- automatic burner control
- electrical board (sign processing)
- differential pressure switch
- exhaust fan
- combined thermostat (bimetal),
- heat-limiter thermostat (100 °C),
- circulating fan

Apart from cleaning of exhaust fan and circulating fan the a.m. components do not need maintenance! The cleaning of fans is expedient to carry out by high pressure air.



**WARNING! Never block the outflow of fume and inflow of combustion air!
Never change the original adjustments what the expert made!
Never allow that water or water-vapour can be got on the appliance!**

For professional maintenance it is practical to conclude a maintenance contract, or call our technical service for regular maintenance!

Tel.: +36 (22) 316-484

mail: szerviz@pakole.hu

If the mains power supply gets damaged, replacement may only be carried out by a qualified person or professional service staff, in order to eliminate hazards.

EXCHANGE PROCESS OF NARROWING PLATE (UNDER EXHAUST FAN)

- disconnect the air and gas supply
- take off the wiring of exhaust fan from electrical board
- take off the silicon pipes of differential pressure switch
- disconnect the flue system from the exhaust fan (taking off 4pcs M4 nuts),
- pull out the flue tube from device
- take off the nuts from the exhaust fan
- take off the exhaust fan
- take off the heatproof insulator sheet
- take off the narrowing plate
- put in the new narrowing plate (the relevant data of narrowing plates is in the enclosure 5)
- put back the heatproof insulator sheet
- put back the exhaust fan
- fix the nuts of device
- fix the flue system to the connection of exhaust fan
- put back the silicon pipes of differential pressure switch (take care of proper/original position)
- connect the wiring of exhaust fan to the electrical board

MAINTENANCE OF REGULATION SYSTEM OF APPLIANCE

Combined regulator thermostat assembled with the appliance ensures the suitable operation of device.

Combined thermostat: 3 positions (Honeywell - L4064):

- FAN OFF – stops the fan – depending on the adjusted temperature.
- FAN ON – starts the fan – depending on the adjusted temperature
- LIMIT OFF – stops the operation of burner – depending on the adjusted temperature

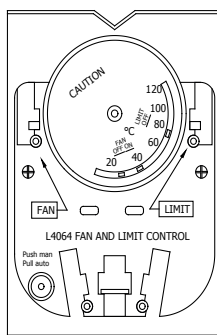

32. picture: Maintenance of regulation system of appliance

The bimetal spring of the thermostat is placed in between the pipes of heating exchanger . It regulates the working of burner and circulating fan during operation. After start the burner works and when the temperature reaches the adjusted value on the thermostat (FAN ON) the fan starts to work. In this case the burner and fan is working together. If the temperature reaches the LIMIT OFF value than the thermostat switches off the burner but the fan is working on. As soon as the temperature decreases under the LIMIT OFF the electronic control starts the burner again.

The values of the combined thermostat is adjusted by the manufacturer so not necessary to modify the values! Only authorized expert or service can change the adjusted values!

Temperature limiter thermostat (RESET thermostat,located next to the combined regulator thermostat) - Switch off the burner in case of overheating (100 °C). In this case – after cooling down – the restart can only be possible by pushing of the "RESET" switch located on the thermostat. This action can only be realized by authorized expert or service!

Expect emergency it is prohibited to disconnect the electrical supply of appliance during operation, because in this case the appliance can be overheated and the exchangers can be burned out. At electrical supply cut, the heat exchangers can little be overheated in case this temperature reaches or surpasses the 100 °C the mechanical temperature limiter thermostat switches on. In such a case the restart can be realized by pushing of RESET button located on the thermostat.



ATTENTION! This action can only be realized by authorized expert or service!



ATTENTION! If the heater appliance is working, than it is prohibited to close the shutters completely!

11. TROUBLESHOOTING

There are installed mode indicator lamps on the front side of appliance:

- GREEN: operation indicator lamp
- RED: error indicator lamp

THE APPLIANCE DOES NOT START

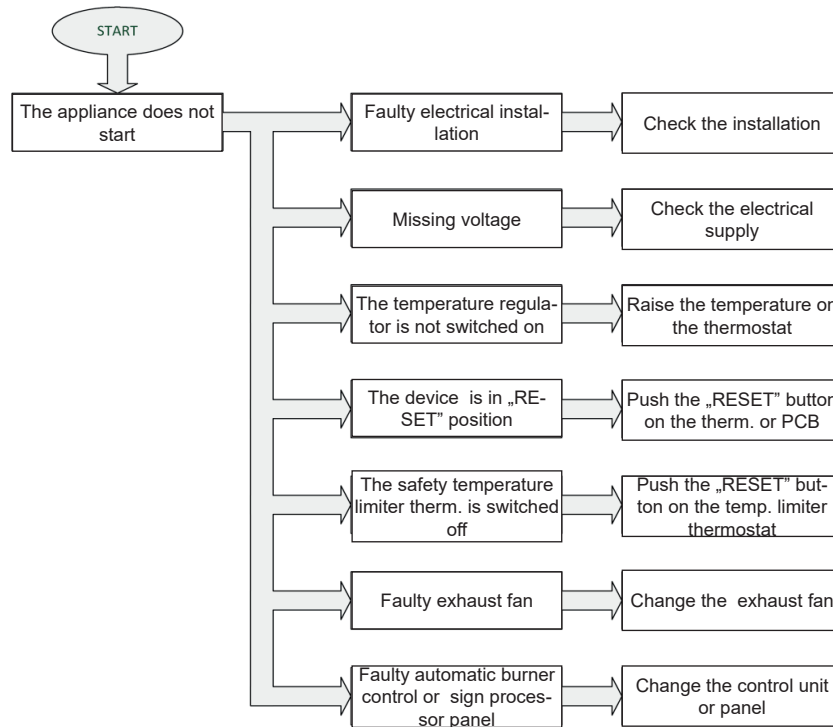

THE APPLIANCE OPERATES CONTINUOUSLY

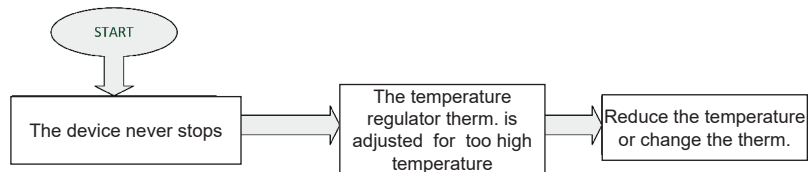

THE APPLIANCE JUST PRE-PURGES

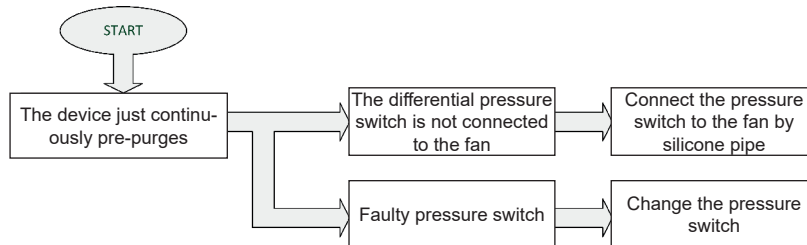

THE APPLIANCE JUST PRE-PURGES

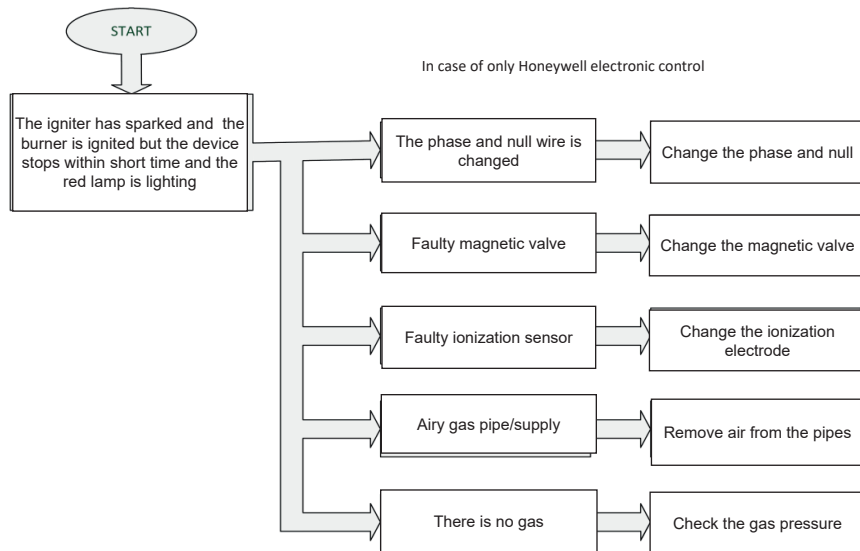

THE APPLIANCE SWITCHES OVER TO SAFETY POSITION

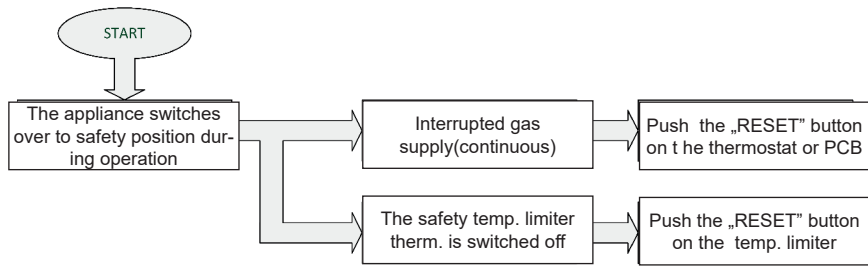

AT STARTING COLD AIR IS FLOWING

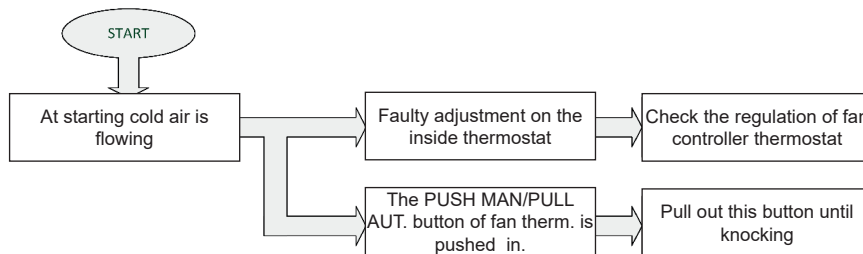

THE APPLIANCE HEATS INSUFFICIENTLY

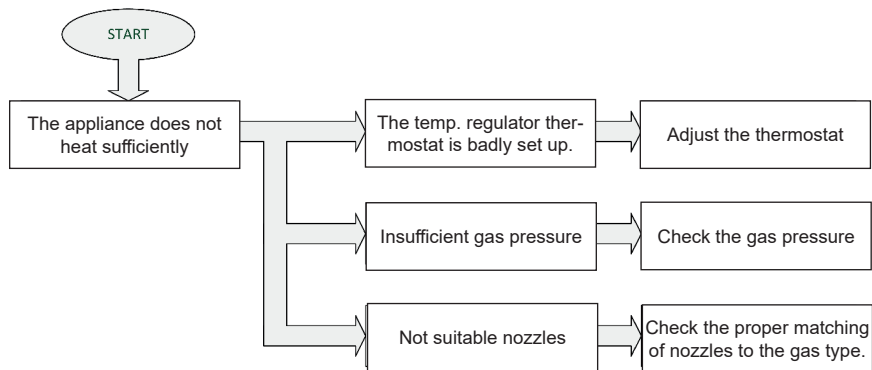

INCREASE OF VALUES OF CO (>200PPM)

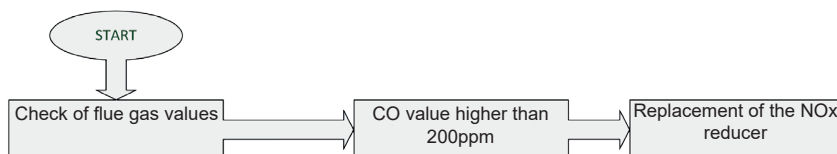

12. ENCLOSURES

ENCLOSURE 1.: APPLIANCE PERFORMANCE DATA

Type			GTV-CON 27/19A	GTV-CON 40/28A	GTV-CON 58/40A
INPUT POWER(NCV)	kW		27/19	40/28	58/40
OUTPUT POWER (NCV)	kW		26,7/17,6	39,9/26,4	58,3/38,4
EFFICIENCY	%		79,1	79,3	79,1
GAS CONSUMPTION	NATURAL GAS	m ³ /h	2,86	4,23	6,14
AIR FLOW		m ³ /h	2790	4160	5890
QUANTITY OF FAN	db		1	1	1
DIFFERENT OF AIR TEMPERATURE ΔT	°C		26,7	26,1	26,3
AIR THROW	m		16	20	25
EXHAUST PIPE / AIR SUPPLY DIAMETER	mm		Ø100/Ø100		
GAS CONNECTION			G1/2" ISO 228 OD		
ELECTRICAL CONNECTION			230V / 50Hz		
NOMINAL CURRENT CONSUMPTION	A		1,5	3,7	3,7
ELECTRICAL PERFORMANCE	W		330	790	790
NOISE LEVEL	dB(A)		53	55	57
WEIGHT	kg		100	123	193
IP PROTECTION OF DEVICE			IP 20		

Type			GTV-CON 27/19 C, CL	GTV-CON 40/28 C, CL	GTV-CON 58/40 C, CL
INPUT POWER(NCV)	kW		27/19	40/28	58/40
OUTPUT POWER (NCV)	kW		26,7/17,6	39,9/26,4	58,3/38,4
EFFICIENCY	%		79,1	79,3	79,1
GAS CONSUMPTION	NATURAL GAS	m ³ /h	2,86	4,23	6,14
AIR FLOW		m ³ /h	2787	4140	5870
QUANTITY OF FAN	db		1	1	1
DIFFERENT OF AIR TEMPERATURE ΔT	°C		26,7	26,1	26,3
AIR THROW	m		16	20	25
EXHAUST PIPE / AIR SUPPLY DIAMETER	mm		Ø100/Ø100		
GAS CONNECTION			G1/2" ISO 228 OD		
ELECTRICAL CONNECTION			230V / 50Hz		
NOMINAL CURRENT CONSUMPTION	A		4,1	5	6
ELECTRICAL PERFORMANCE	W		870	1090	1280
NOISE LEVEL	dB(A)		58	58	58
WEIGHT	C - TYPE	kg	115	145	214
	CL - TYPE		121	149	220
IP PROTECTION OF DEVICE			IP 20		

ENCLOSURE 2.: APPLIANCE DIMENSIONS

GTV-CON-...A AXIAL FAN-TYPE 27...58 kW

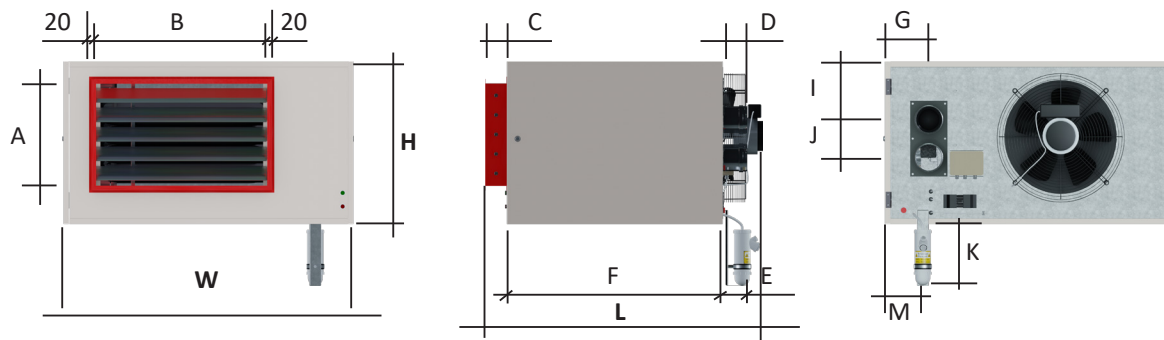

	W	H	L	A	B	C	D	E	F	G	I	J	K	M
GTV CON-27/12 A	1080	600	1030	359	600	85	60	91,5	800	165	215	140	230	141,5
GTV CON-40/18 A	1080	670	1030	499	600	85	60	91,5	800	165	247	140	230	141,5
GTV CON-58/26 A	1170	800	1090	639	600	85	60	91,5	800	232	300	140	230	141,5

GTV-CON-...C CENTRIFUGAL FAN-TYPE 27...58 kW

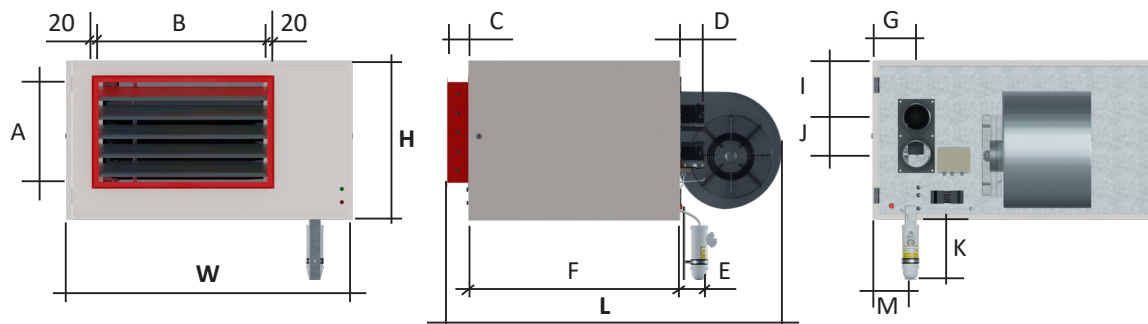

	W	H	L	A	B	C	D	E	F	G	I	J	K	M
GTV CON-27/12 C	1080	600	1370	359	600	85	60	91,5	800	165	215	140	230	141,5
GTV CON-40/18 C	1080	670	1420	499	600	85	60	91,5	800	165	247	140	230	141,5
GTV CON-58/26 C	1170	800	1420	639	600	85	60	91,5	800	232	300	140	230	141,5

GTV-CON-...CL CENTRIFUGAL FAN-TYPE 27...58 kW

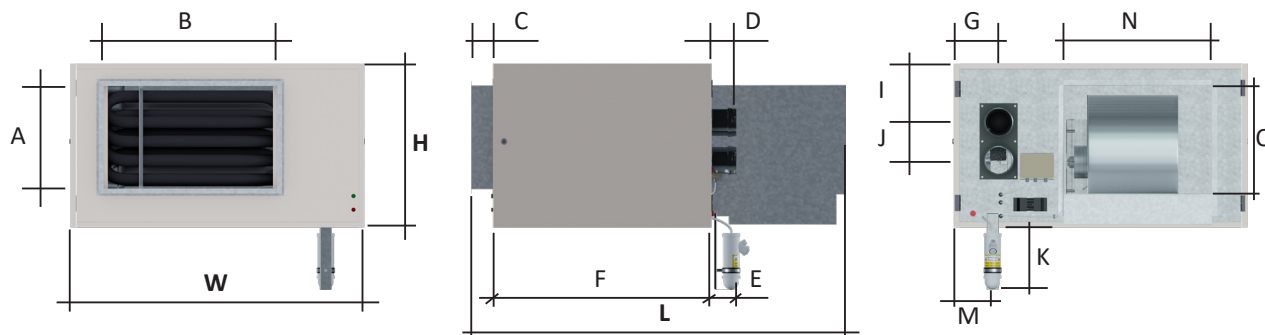

	W	H	L	A	B	C	D	E	F	G	I	J	K	M	N	O
GTV CON-27/12 CL	1080	600	1380	359	600	85	60	91,5	800	165	215	140	230	141,5	545	400
GTV CON-40/18 CL	1080	670	1430	499	600	85	60	91,5	800	165	247	140	230	141,5	600	509
GTV CON-58/26 CL	1170	800	1430	639	600	85	60	91,5	800	232	300	140	230	141,5	600	509

ENCLOSURE 3.: FLUE LONGS, ALLOWED PRESSURE DROPS

 **ATTENTION! The joint of pipes must be sealed and fixed! Not allowed longer flue system as the above chart shows!**

Supplement: The fresh air supply and venting set can contain an elbow 90°. In case of use more elbows, you need to reduce the length of fresh air supply and venting set, as follow:

- the pressure drop of 1m Inox Ø100 mm pipe is 2 Pa
- elbow 90° is equal about 1m length pipe 2 Pa

 **It is allowed to use longer fresh air supply and venting set with isolation and condensate outlet. In this case, contact the manufacturer!**

Type	GTV-CON 27/19A /C /CL	GTV-CON 40/28A /C /CL	GTV-CON 58/40A /C /CL
Input power (NCV)	27/19	40/28	58/40
Output power (NCV)	26,7/17,6	39,9/26,4	58,3/38,4
Venting set type	Maximal lenght of venting set Ø 100 mm [m]		
B22	8	8	8
C12	8	8	8
C32	8	8	8
C52	8	8	8
Venting set type	Maximal pressure drop of venting set Ø 100 mm [Pa]		
B22	8	12	16
C12	8	12	16
C32	8	12	16
C52	8	12	16

ENCLOSURE 4.: GAS CONSUMPTION

Type			GTV-CON 27/19	GTV-CON 40/28	GTV-CON 58/40
INPUT POWER(NCV)	kW		27/19	40/28	58/40
OUTPUT POWER (NCV)	kW		26,7/17,6	39,9/26,4	58,3/38,4
GAS CONSUMPTION	NATURAL GAS	m³/h	2,86	4,23	6,14

ENCLOSURE 5.: TARGET COUNTRIES/GAS CATEGORIES

Modell	Appliance category	Gas pressure of connection (mbar)	Target countries
GTV-CON 27/19A, C, CL GTV-CON 40/28A, C, CL GTV-CON 58/40A, C, CL	I _{2H}	20	<i>DK, EE, FI, LT, LV, NO, SE</i>
	I _{2E}	20	<i>LU, DE</i>
	I _{2H}	20	<i>BA, BG, MD, RO, RU, SK, UA, HR, RS</i>
		20	<i>CH, ES, GB, IE, PT, SI</i>
		20	<i>CZ, GR, IT</i>
		20	<i>AT, TR</i>
	I _{2E}	20	<i>PL</i>
	I _{2H}	25	<i>HU</i>

The appliances were tested together with the flue system, recommended by the manufacturer.
 The applied flue system parts: **LIM-MONT ECO DIM, DW,**
LIM-MONT ECO DIM DE.

ENCLOSURE 6.: ECO-DESIGN DECLARATION OF CONFORMITY

Modell: **GTV-CON 27/19A Modulation controlled gas-fired forced convection air heater with axial fan**

B₁ Warm air heater: No

C₂ Warm air heater: No

C₄ Warm air heater: No

Type of fuel: Gas

Item	Symbol	Value	Unit	Item	Symbol	Value	Unit
Capacity				Useful efficiency			
Rated heating capacity	$P_{rated,h}$	26.75	kW	Useful efficiency at rated heating capacity	η_{nom}	89.12	%
Minimum capacity	P_{min}	17.69	kW	Useful efficiency at minimum capacity	η_{pl}	87.95	%
Electric power consumption				Other items			
At rated heating capacity	el_{max}	0.068	kW	Envelope loss factor	F_{env}	0.0	%
At minimal capacity	el_{min}	0.050	kW	Ignition burner power consumption	P_{ign}	0.0	kW
In standby mode	el_{sb}	0.0	kW	Emissions of nitrogen oxides	NO_x	85.4	mg/kWh input energy (GCV)
Regulation (EU) 2016/2281				Emission efficiency	$\eta_{s,flow}$	93.19	%
				Seasonal space heating energy efficiency	$\eta_{s,h}$	79.1	%

Modell: **GTV-CON 40/28A Modulation controlled gas-fired forced convection air heater with axial fan**

B₁ Warm air heater: No

C₂ Warm air heater: No

C₄ Warm air heater: No

Type of fuel: Gas

Item	Symbol	Value	Unit	Item	Symbol	Value	Unit
Capacity				Useful efficiency			
Rated heating capacity	$P_{rated,h}$	39.99	kW	Useful efficiency at rated heating capacity	η_{nom}	89.3	%
Minimum capacity	P_{min}	26.44	kW	Useful efficiency at minimum capacity	η_{pl}	88.1	%
Electric power consumption				Other items			
At rated heating capacity	el_{max}	0.072	kW	Envelope loss factor	F_{env}	0.0	%
At minimal capacity	el_{min}	0.060	kW	Ignition burner power consumption	P_{ign}	0.0	kW
In standby mode	el_{sb}	0.0	kW	Emissions of nitrogen oxides	NO_x	84.2	mg/kWh input energy (GCV)
Regulation (EU) 2016/2281				Emission efficiency	$\eta_{s,flow}$	93.16	%
				Seasonal space heating energy efficiency	$\eta_{s,h}$	79.3	%

Modell: **GTV-CON 58/40A Modulation controlled gas-fired forced convection air heater with axial fan**

B₁ Warm air heater: No

C₂ Warm air heater: No

C₄ Warm air heater: No

Type of fuel: Gas

Item	Symbol	Value	Unit	Item	Symbol	Value	Unit
Capacity				Useful efficiency			
Rated heating capacity	$P_{rated,h}$	58.33	kW	Useful efficiency at rated heating capacity	η_{nom}	89.4	%
Minimum capacity	P_{min}	38.45	kW	Useful efficiency at minimum capacity	η_{pl}	88.0	%
Electric power consumption				Other items			
At rated heating capacity	$e_{l,max}$	0.095	kW	Envelope loss factor	F_{env}	0.0	%
At minimal capacity	$e_{l,min}$	0.074	kW	Ignition burner power consumption	P_{ign}	0.0	kW
In standby mode	$e_{l,sb}$	0.0	kW	Emissions of nitrogen oxides	NO_x	97	mg/kWh input energy (GCV)
Regulation (EU) 2016/2281				Emission efficiency	$\eta_{s,flow}$	92.98	%
				Seasonal space heating energy efficiency	$\eta_{s,h}$	79.1	%

13. GUARANTEE AND SERVICES

PRESERVE THIS WARRANTY

Type: _____

Serial no.: _____

Date of purchasing: _____

LIMITED GUARANTEE *

The manufacturer guarantee the customer that the product and its parts are free from material and production failures. During normal use the warranty is 2 years. This warranty concerns the first retail customer.

The guarantee concerns the costs of laboratory investigations and the parts, which are needed for proper operation. The delivery and unforeseeable costs belong also to the mending costs and do not contain compensation costs.

Guarantee mending can only be realized by authorized retailer or service centre.

The guarantee does not concern the following failures, which are caused by: improper using, damaging, neglect, accident, lack of maintenance, normal attrition, transformation, modification and operation influenceable factor, contaminated fuel, installation of non-suitable part and mending which is done by not authorized retailer or service station.

The regular maintenance is the owner's responsibility.

The manufacturer does not assume the responsibility in case of accidentally happened or directly caused mistake respectively improper using.

*We reserve the right to change of this specification without extra notification. The guarantee can be applied in accordance with above defined.

Additional guarantee is not accepted.

Guarantee servicing

If your appliance needs guarantee service in that case it can be requested at nearest authorized service station giving in the appliance for repairs.

Mending services

Take the appliance to the nearest authorized service station. If the device is not under guarantee the service cost will be invoiced to the customer at defined price. The service centres are independent from one another and may have different owners. We reserve the right to change of this specification without extra notification. If you would like to contact us the type and serial number of device always be at hand. In case of other needed information write to the following address:

PAKOLE TRADE Kft.
H-8000 Székesfehérvár, Börgöndi út 8-10.
e-mail: szerviz@pakole.hu
Tel.: +36 22 316 484



PAKOLE

www.pakole.com

PAKOLE TRADE Ltd.

H-8000 Székesfehérvár, Börgöndi út 8-10.

web: www.pakole.com

e-mail: mail@pakole.hu

Tel.: +36 22 316 484