



PAKOLE

INSTRUCTIONS FOR INSTALLATION AND SERVICING

Intended for Installer

AIR HEATERS BURNING GASEOUS FUELS

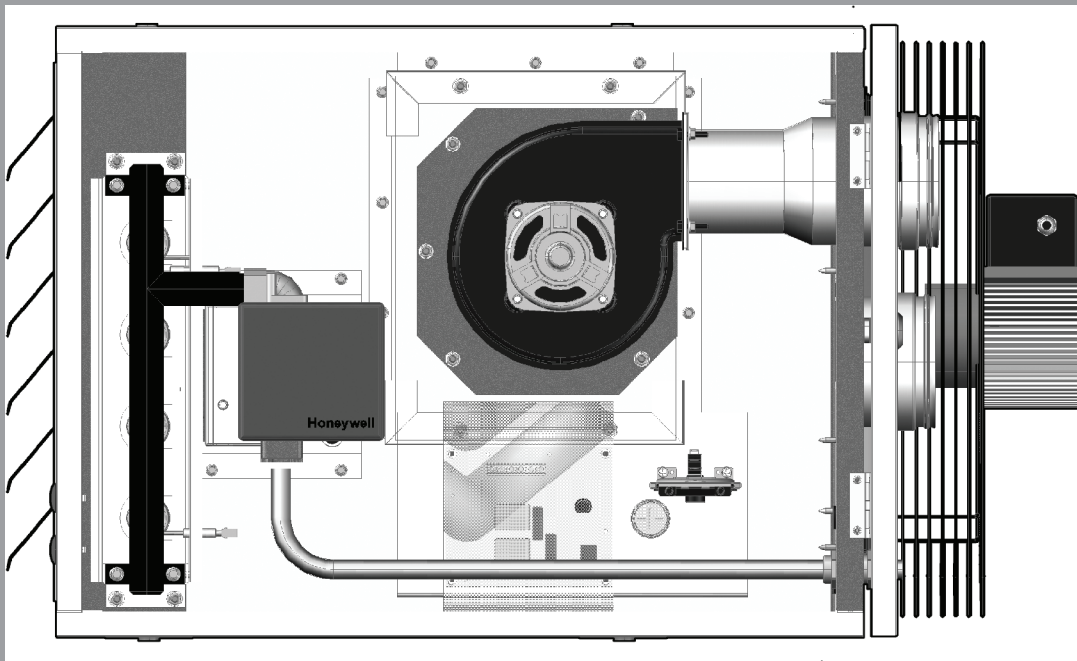

Appliance types:

GTV-E-20A, C, CL
GTV-E-27A, C, CL
GTV-E-33A, C, CL
GTV-E-40A, C, CL
GTV-E-48A, C, CL
GTV-E-58A, C, CL

GTV-E-68A
GTV-E-87A
GTV-E-107A

www.pakole.com

GTV_E_008_027_011_200220_V002_EN

EN

Contents

1. SAFETY INFORMATION	3
2. GENERAL INSTRUCTION	4
Installer's responsibilities	4
Data board	4
Corrosive materials	5
Standards and laws.....	5
Safety signs.....	5
Safe usage	5
3. TRANSPORTATION, UNPACKING, HANDLING	6
4. OPERATION PRINCIPLE	6
Reduced NOx emissions.....	7
Inside structure.....	7
Outside structure.....	8
Positions of structure components.....	8
Appliance types.....	9
5. INSTALLATION	10
Appliance installation	10
Gas connection	10
Electrical connection	11
Connection cable data	11
Electrical connection	12
Optional accessories.....	16
Type of electric socket	16
Electrical connecting specification	16
Regulation possibilities.....	17
6. APPLIANCE SPECIFICATION	17
Ventilation.....	17
Protective distances	18
7. FIXING AND EXHAUST SYSTEM POSSIBILITIES	18
Fixing possibilities	18
Suspension-type installation	20
Exhaust systems	21
Types of exhaust system.....	21
minimal distance of the air supply and venting sets.....	24
8. ACCESSORIES	25
9. APPLIANCE OPERATION	26
Start, restart	26
Control and regulation of appliance	26
10. MAINTANCE	28
Maintenance procedures.....	28
Gas change.....	30
Process of nozzle exchange	30
Exchange process of narrowing plate (under exhaust fan).....	30
Maintenance of regulation system of appliance	31

11. TROUBLESHOOTING	32
The appliance does not start.....	32
The appliance operates continuously.....	32
The appliance just prepurges.....	32
The appliance just prepurges.....	33
The appliance switches over to safety position.....	33
At starting cold air is flowing.....	33
The appliance heats insufficiently	33
Increase of values of CO (>200ppm).....	33
12 . ENCLOSURE	34
Enclosure 1 / A . : Appliance performance data	35
Enclosure 1 /B . : Appliance performance data	36
Enclosure 2.: appliance dimensions per types.....	36
Enclosure 3.: Flue longs, allowed pressure drops	37
Enclosure 4.:Target countries/gas categories	38
ECO-Design Megfeleősségi nyilatkozatok.....	39

1. SAFETY INFORMATION

 **Read and understand this manual thoroughly before installing starting or servicing this equipment. The improper installation or using can cause serious damages! Keep this manual in a safe place in order to obtain information in case of incidental problems!**

GENERAL SAFETY NOTICES

 **Disregard of instructions and notices of this Instruction for installation and servicing can cause serious bodily injuries or damages as follows: burning, explosion, suffocation, carbon monoxide poisoning, electric shock and in extreme case death!**
This appliance can only be used and serviced by such persons who understood and follow the instructions of this Instruction for installation and servicing If you need help or information concerning the appliances – for example installation guide or labels etc. – in that case contact with the manufacturer! This appliance must not be used by children and mentally or sensitively deficient persons! Take care that the children do not handle it and do not play with devices!

 **WARNING! Fire, burning, inhalation and explosion hazard! Keep all flammable objects as follows building materials, papers, or carton unites away from heater according to the instructions! Never use this appliance in such rooms where there are flammable volatile materials or the following materials, which can get into the device: petrol, solvent, thinner, fine grained dusty or unknown chemical materials!**

 **WARNING! This appliance can not be used in domestic circumstances or mobile home!**

WARNING! For your safety, if you smell gas do the followings:

-  - **Open windows.**
 - **Do not try to light any appliance.**
 - **Do not use electrical switches.**
 - **Do not use any telephone in your building.**
 - **Leave the building.**
 - **Immediately call your local gas supplier after leaving the building. Follow the gas supplier's instructions.**
 - **If you cannot reach your gas supplier, call the Fire Department.**

The GTV-E-type warm air blower appliances have been developed and certified in compliance with EN 1020 standard and qualified for heating of industrial rooms! The function of these heater appliances to ensure heating of appointed workplace temporarily or continuously! In case of proper using the appliance guarantees safety and energy-saving operation! The combustion products issued during combustion process leave through the flue system into the open air. In case of further possible questions regarding the applicability please turn to the local Fire Protection Office!

Other standards can give you directions in terms of proper using of natural and propan gas as follows: leading/piping, storing etc.! Concerning the detailed content of these standards the local Bureau of Standards can help.

Carbon- monoxide poisoning: The initial symptoms of carbon-monoxide poisoning are similar to influenza namely headache, dizziness and/or nausea! If these symptoms are observed in that case the appliance probably does not work satisfactorily! First of all go fresh air, ventilate the rooms and have the appliance investigated!

Propan-gas: The propan-gasis odourless! Mercaptan-derivative as scented component is mixed into the gas to be able to observe the possible escape! In spite of the typical smell is not felt the propan gas can be present in the environmental air in case of escaping!

2. GENERAL INSTRUCTION

- Make sure that read and understood all the warnings, correct keeping of which can guarantee the safety and faultless operation !
- During the installation be always circumspect! Follow the valid instructions and recommendations!
- The appliance can be operated by specified voltage and frequency marked on its data board! The electrical connections and groundings are prepared as per EN 60335 standard!
- Electrical grounding specification: present appliance is equipped with three points grounding connection in the interests of your protection!
- It needed to ensure the sufficient quantity of combustion air if the appliance is installed without outside air supply!
- Keep away the device from the following strong effects: wind, high pressure water jet, rain or dropping water!
- The appliance must not be used in the open air!
- The application of device is **STRICTLY PROHIBITED** in such rooms, which are used for sleep or continuous stay!
- Keep away the flammable materials from the appliance and its near environment as follows: fuels, thinner or other flammable fluids and vapours!
- In the interests of avoiding of dust explosion do not used the device in such rooms where the degree of dust concentration is high if the device is installed without outside air supply!
- Before starting of appliance in every case check it in order to detect the possible damages! Never use damaged equipment!
- In case of Propan-gas operation never install the device in basement or from that lower being rooms! The propan-gas is heavier specific gravity than the air for this reason in case of possible escaping it will spread towards the lower located rooms !
- Only use that kind of flexible gas pipe and pressure regulator, which is offered for the appliance by the manufacturer!
- Before every starting of heater appliance check the condition of connecting gas hose and if it is particularly worn or damaged in that case exchange it for a new one specified by manufacturer!
- Preserve the equipment in genuine condition, do not leave it to grow old!
- Do not use seriously aged equipment any longer!
- Fix the appliance on such stable surface, which during operation despite warming of appliance preserves its stability !
- If the appliance is put out of use in every case it must be cut off the current and gas!
- Never block the air supply and exhaust pipes!
- Keep away the children and animals from the equipment!
- Never service/mend such devices, which are hot and during operation or electrical charged!
- Never mount such air duct unit on front or back side of device, which is not approved by manufacturer!
- Use exclusively genuine-approved by manufacturer-spare parts, do not install similar quality spare parts for substitution! These kind of substitute parts can cause serious damages concerning the operation of appliance!
- Fix the appliance on such stable surface, which during operation despite warming of appliance preserves its stability !
- If the appliance is put out of use in every case it must be cut off the current and gas!
- Never block the air supply and exhaust pipes!

INSTALLER'S RESPONSIBILITIES

- making up of gas and electrical connection in compliance with the specifications (it is proposed to connect with the local Building Supervisory Authority or Fire-service),
- installation of equipment in accordance with the definitions of this manual,
- installation according to the fire prevention rules,
- supply of the necessary materials/components for installation(which are not belong to appliance),
- planing of air duct systems (ventilation/connections)
- service execution,
- placing the copy of present manual at owner's disposal,
- assuring of sufficient air circulation around the appliance,
- determination and assuring of needed air for burning, ventilation and blowing in according to the specifications.

DATA BOARD

The appliance is equipped with data board, which is placed on inside of device's door. On this data board there are information concerning the type of device, gas type, electrical connection and flue types.

Manufacturer PAKOLE Trade Kft. 8000 Székesfehérvár, Börgöndi út 8-10.		Type GTV-E-20A-3P		 EAC UA.TR.012-10 CE 1015 19 PIN: 1015 CU 0716 Date/place of production 20.02.2020
Electrical protection: IP20		Nominal input: 21 kW	Pconnecting max.: 60 mbar	
Electrical connection: AC 230V 50Hz		Jet pressure: 7 mbar	Pconnecting min.: 20 mbar	
Max.current entry: 0,95 A		Stat. air pressure: 30 Pa	Airflow: 2520 m³/h	
Electrical power: 218,5 W		Gas type: Naturalgas	Targeted country: IE NOx 4	
Category: I2H, I3P, II2H3F				
Series number: 113-10398-2				

1. picture: Data board

CORROSIVE MATERIALS

WARNING! Do not use the appliance in such place where corrosive materials can be in the air! If the appliance has to be applied in this circumstances outside air has to be ensured for combustion air and circulation as well („CL” type)!

The manufacturer can not assume responsibility for fault of equipment in case the installation is not happened according to the above. This responsibility concerns completely the installer. In order to avoid such eventualities, if it is not certain to fit to the building or activity, ask our colleague for help

Both the owner and the installer have to identify every possible material, which can be present in the building (inflammable materials, corrosive materials, halo hydrocarbons etc.), and with knowledge of these materials must be planed the heater system!

STANDARDS AND LAWS

Every appliance installation must be satisfied the valid laws and standards. These laws refer to the gas and electrical installation respectively the ventilation (special specifications refer to park houses, airplane hangars etc).

SAFETY SIGNS

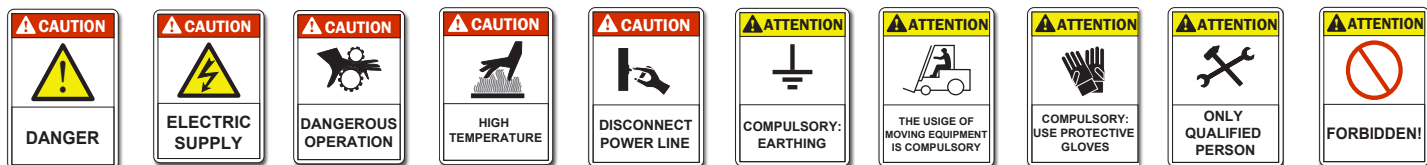

SAFE USAGE

CAUTION DANGER **ATTENTION ONLY QUALIFIED PERSON**

Please observe the following rules during installation, first set-up, usage or maintenance:

- Installation must be carried out always strictly complying with the current standards of the country where the appliance is going to be used and following, of course, the instructions given by the producer.
- The installation and maintenance operations of the unit can be carried out by qualified and trained personnel only.

Qualified service engineers are those having specific technical experience and/or valid license in the field of heating and cooling installation for home and industry. In any case, call the Manufacturer office or the closest dealer (www.pakole.com) and ask for further informations.

				<ul style="list-style-type: none"> • According to the installation project, install the electric power lines. • Always make sure that the unit and all its electrical parts have been correctly earthed prior starting up the unit.
				<ul style="list-style-type: none"> • If you have to disassemble the unit, use special protective gloves. • Beware of sharp edges inside the unit! • Beware of roof corners of outdoor units! • Keep suction grids always clear!
				<ul style="list-style-type: none"> • Before cleaning or maintaining the unit, make sure that all electrical parts have been switched off, the appliance gas supply chain is closed and wait until the appliance cools down. In particular, make sure that the fan is off and cannot be inadvertently started prior to opening inspection panels. • Fans can reach a speed of 1000 RPM. Do not insert any object nor hands in the electric fan.
				<p>CHECK THE EARTHING !!</p> <ul style="list-style-type: none"> • We recommend to install a safety switch which can be easily reached to cut off the current, near the unit. Before any cleaning and servicing operation, cut off the power line to the unit. • Before opening the unit, make sure that all electrical parts have been switched off. In particular, make sure that the fan is off and cannot be inadvertently started prior to opening inspection panels.

CAUTION DANGER

- This unit is designed to be used for heating purposes only. Any different use is not allowed as it may be dangerous.
- Should the unit work in a house where disabled people and/or children live, it must be placed safely away from their reach. Always make sure that the access door to the inside control board stay locked.
- An incorrect installation can cause damages to people, animals and property. In case of erroneous installation, the manufacturer cannot be held responsible for such damages.
- **The manufacturer cannot be held responsible for such damages by improper uses, errate uses, etc.**



- Never use the unit to support other equipment.
- Never leave tools, spare parts, etc. inside the unit.
- Make sure that all inspection panels are closed properly.
- Do not expose the unit to inflammable gases.



- In case of breakdown or failure: turn unit off, do not try to repair it on your own, call operator.
- If you are going to leave the heater switched off for a long time, first make sure that in no way this could cause harm to anyone in any way.

3. TRANSPORTATION, UNPACKING, HANDLING

- The delivery must be made according to the following:
 - The package must be carefully secured in the loading space.
 - The package must be transferred in a closed space (always keep packing parts away environmental impacts).
- The unit has a special safety packing for transport and delivery which must be kept in good conditions till the unit is positioned on the installation place.
- Make sure that the unit has all its parts, as specified in the order.
- Check if there are any damages and if the unit abbreviation is the same as the one of the ordered model.
- Every unit is factory tested before shipment, therefore, if there are damages, report them immediately to the carrier.

Transporting, unloading and moving is a process which must be made carefully to avoid any kind of damages. Try not to use the unit's components as hand holds. When lifting, bear in mind that the centre of gravity of the unit may be off-centre.

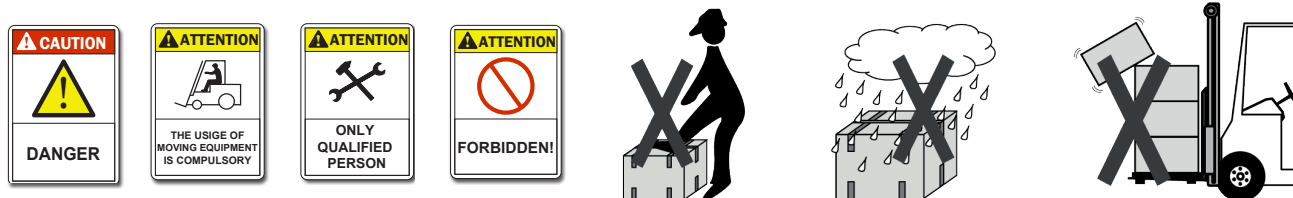

The device is placed in cardboard box, one-way pallets are delivered.

Unpacking process:

- remove the bands from packing of device, the carton box and the covering foil. Screw off the 4 pcs M8x45 fixing bolts on back side of pallet hereby the device can be removed from pallet.
- **do not remove the protection caps from device and gas installing set until the gas attachment**
- investigate the device if it is not damaged during the transportation
- if it is damaged in that case notify the retailer from whom the device was bought!

There is an envelope inside the unit containing the Instructions for Installation and Servicing, User's Guide use and Guarantee and services and the warranty documents.

4. OPERATION PRINCIPLE

The appliance operates based on direct heater principle, that means the heater air is blown into the heated room directly for assuring of requested temperature. Besides HEATING (winter) mode the appliance can achieve the VENTILATION of room as well (summer mode).

Principle: The warm air blower appliance burns up the sucked mixture of combustion air and gas (S-,L-,Propane or natural gas), in this way making the heater air, which is blown into the heated room (by direct blowing or through air duct) in order to ensure the keeping of temperature on requested value.

The heating and consumption values to be found as per appliance and gas types in the **enclosure 1.b**.

The supply of combustion air of appliance can be realized in two ways:

- directly from the heated place (A,C)
- from open air (CL), it can be used in case of such plants, which are working with dangerous materials as follows: painting workshops and workshops, which are using explosive or corrosive materials etc...

The combustion products flow through the exchanger pipes towards the flue system while heat up it, parallel with this process the blower fan circulates the sucked inside or outside air through the heat exchanger assuring the needed warm air for heating. (the heater air is average 50°C)

The air supply of blower fan can be solved in two ways:

- by direct sucking in from the heated place (A, C, CL types),
- by sucked in from outside (CL type).

The made warm air can be passed into the heated place in two ways:

- by direct blowing in through the leading lamella (A, C types),
- by blowing in and leading through air duct to the demanded places (in this case there are no lamella on the device). Such as the C and CL type of GTV-E.

The technical data of appliance can be found in the **enclosure 1**.

REDUCED NOx EMISSIONS

The GTV-E air heater operates with reduced NOx emissions in accordance with EU Regulation 2281/2016, which entered into force on 1 January 2018. Nitrogen oxide emissions from gas-fueled air-heaters under this Regulation shall not be higher than 100 mg / kWh. This section of the regulation is compliant with the GTV-E type of GTV-E air heaters. The Declaration of Conformity can be downloaded from our website (www.pakole.com) and found on the last pages of this Instructions for installation and servicing.

The technical solutions for the development of GTV-E with a reduced NOx emission air heater appliance:

- NOx reducer placed in a flue pipe
- pressure compensation plate placed in the flue gas chamber
- a blower fan with increased air flow

These supplements prevent the creation of favorable conditions for the formation of NOx which are the result of the formation of flame and high flame temperatures and the long residence time of the molecules in the flame during combustion.

ATTENTION!
 **During regular maintenance, service technicians must check the status of the NOx reducers (physical damage, dirt, lack of material, etc.) and must measure the value of carbon monoxide emissions. If this value is above 200ppm, the replacement of the NOx reducer elements is compulsory !!!**

INSIDE STRUCTURE

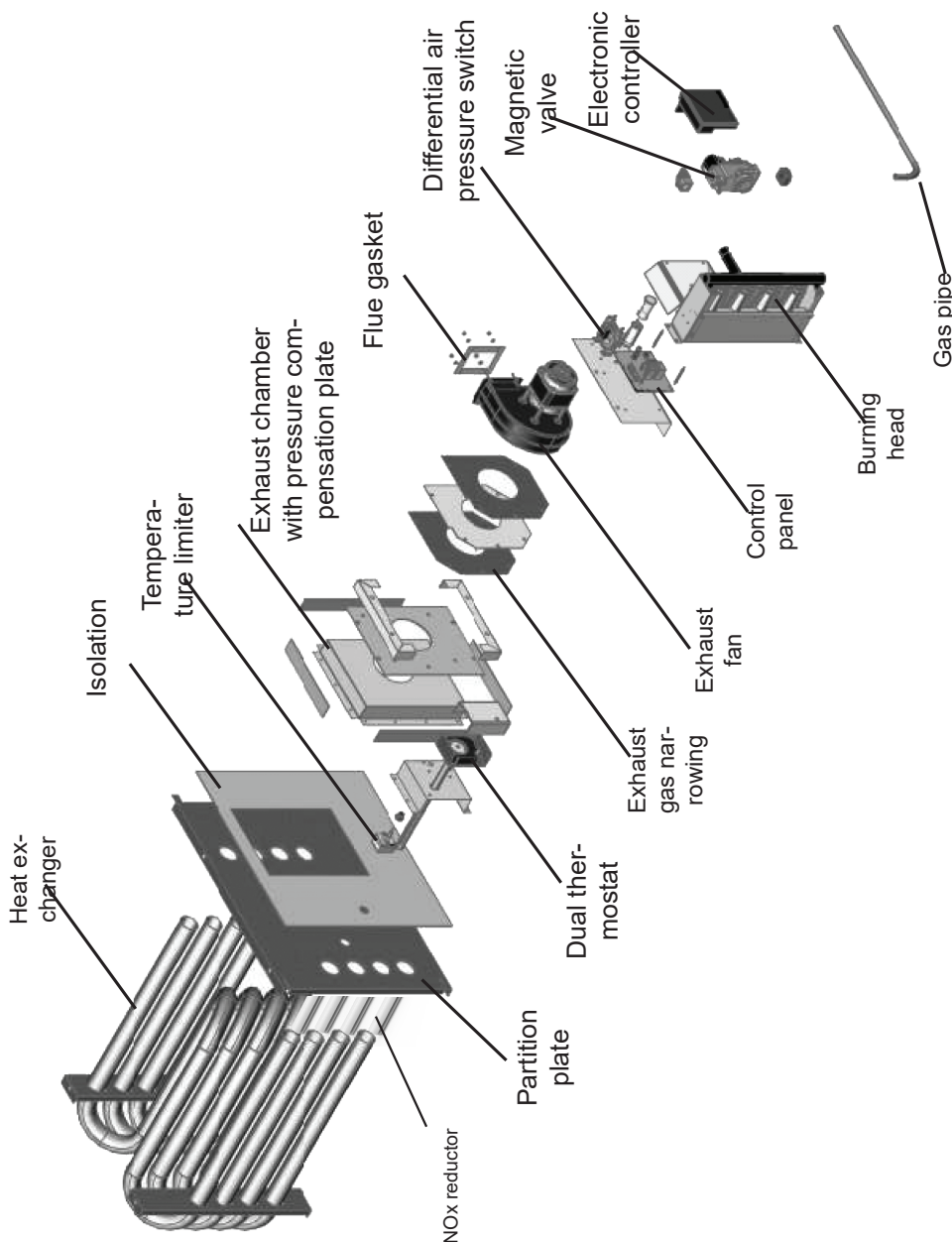

OUTSIDE STRUCTURE

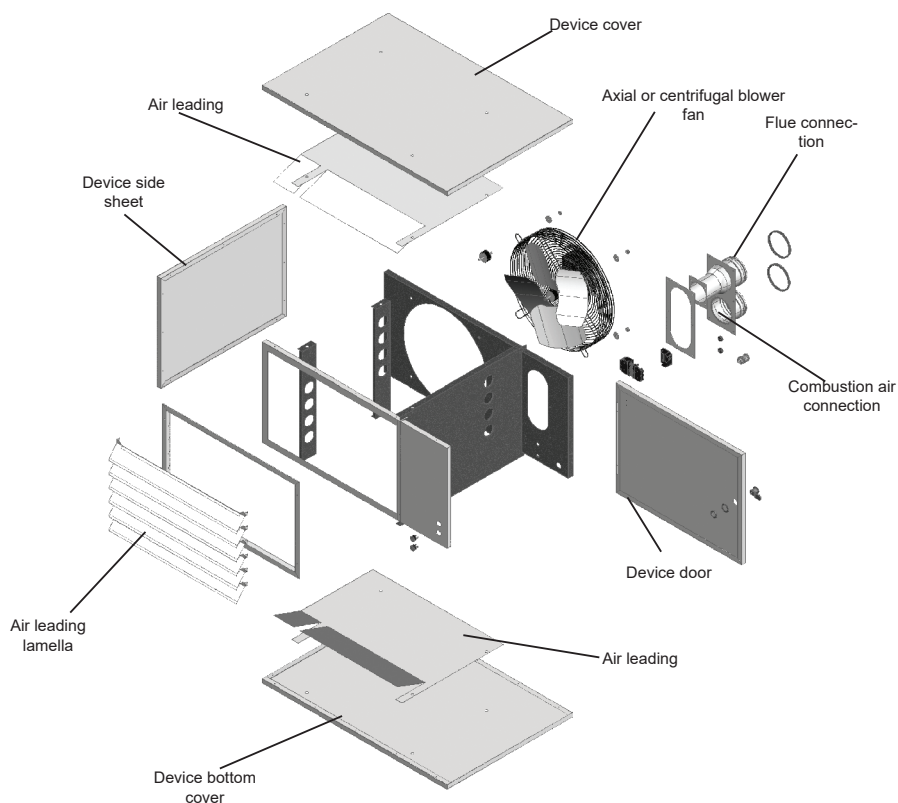

3. picture: Outside structure of appliance

POSITIONS OF STRUCTURE COMPONENTS

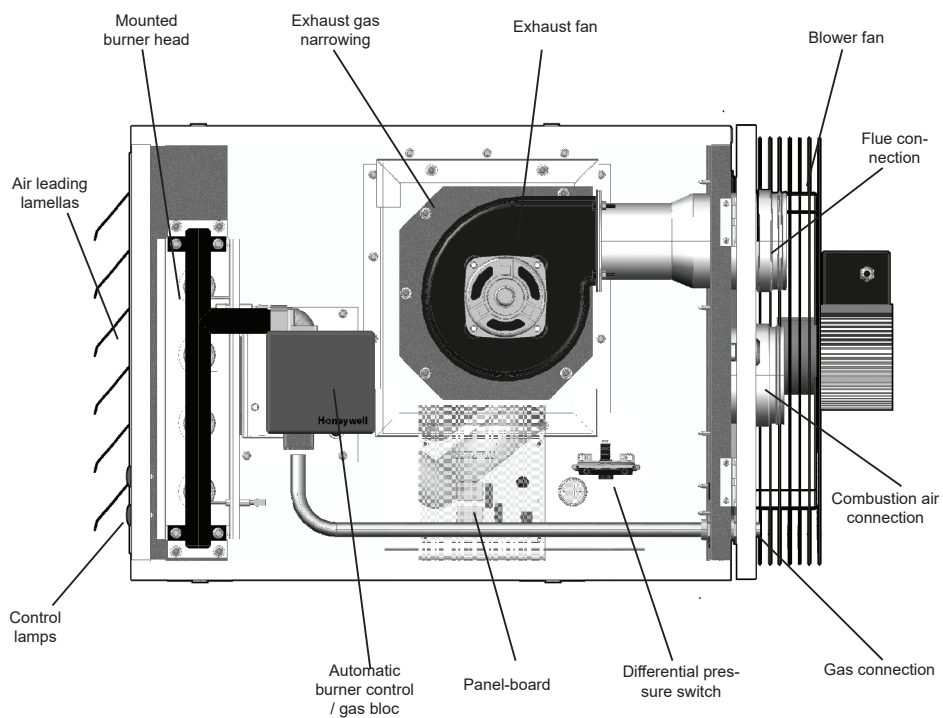

4. picture: Main components of appliance

APPLIANCE TYPES

The overall dimension of appliances are in **enclosure 2**.

AXIAL FAN-TYPE EXECUTION (GTV-E-...A)

Features:

- suction in of heater air is executed from the heated place, it can not be connected to air duct
- blowing in of warm air is executed directly through the air leading lamella

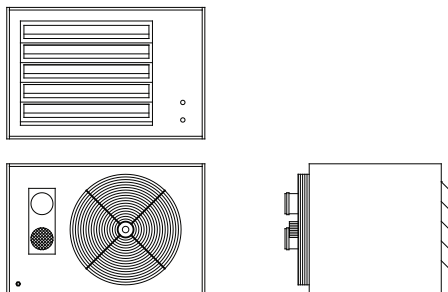

5. picture: Axial fan-type warm air blower

CENTRIFUGAL FAN-TYPE EXECUTION (GTV-E-...C)

Features:

- suction in of heater air is executed from the heated place,
- blowing in of warm air is executed directly through the air leading lamella or through the attached air duct to the demanded places

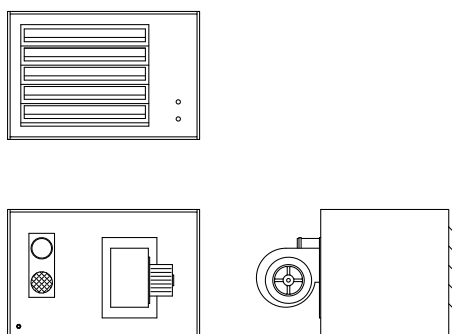

6. picture: Centrifugal fan-type with lamella execution

CENTRIFUGAL FAN-TYPE EXECUTION (GTV-E-...CL)

Features:

- suction in of heater air can be from inside or outside respectively in case of installed „winter-summer” mode relay the suction in of mixed inside-outside air is executed through air duct
- blowing in of warm air is executed through the attached air duct system to the demanded places

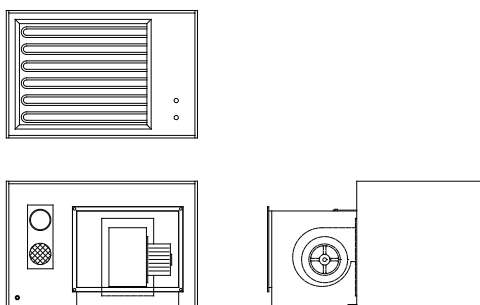

7/a. picture: Centrifugal fan-type with air duct execution

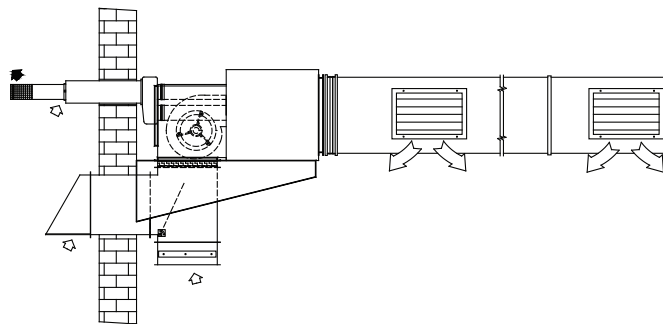

7/b. picture: Air duct execution at „CL” type

5. INSTALLATION

APPLIANCE INSTALLATION

- **SOLELY INTERIOR** installation is possible,
- for the sake of appropriate efficiency the position and the high of installation has to be carefully defined,
- the mounting of appliance can be executed by cantilever respectively suspension
- the appliance has to be placed in that way that its every part be accessible.

GAS CONNECTION



WARNING! The appliance can only be operated by gas defined on the data board of appliance !



The nominal values of gas-supply pressure:

- in case of natural gas: 25 mbar (min. 20 mbar – max. 60 mbar)
- in case of Propan gas: 50 mbar

The allowed maximum pressure of gas-supply: 60 mbar!



WARNING! If the pressure of gas-supply is higher than 60 mbar in that case the using of pressure regulator is indispensable because the max. allowed pressure of double-closed magnetic valve is: Pmax = 60mbar

The pressure regulator can be installed before each appliance or centrally namely one piece into the gas-supply pipe. In case of unique solution - namely there is pressure regulator before each appliance – before every pressure regulator, in case of centrally mounted pressure regulator before pressure regulator and each appliance **MUST BE INSTALLED GAS FILTER** to be able to avoid the blocking of appliance's gas magnetic valves, which can be caused by possible contamination settled in the supply pipes.(despite blowing out of pipes it can be present)

The connection to the gas-supply pipe must be from above or side (Fig.8) because in case of bottom connection the possible contaminations settled on the pipe can influence the proper operation of equipment.

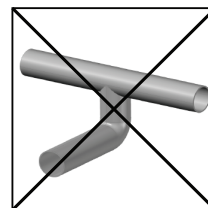
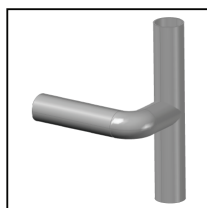
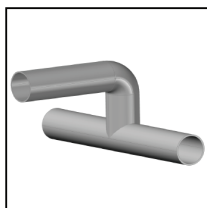

Appropriate connection

Incorrect connection

8. picture: Connection to gas-supply pipe

The gas connection must be accomplished by flexible gas pipe. Use such flexible gas pipe for connection, which renders 100mm free moving possible. The flexible gas pipe must be mounted free from torsion! Recommended to apply gas connection set (flexible gas pipe, gas filter, 1/2" or 3/4" shut off valve) marketed by PAKOLE Ltd.(Pic.9). If there is installed pressure regulator per appliance then it must be mounted between the gas filter and flexible gas pipe.

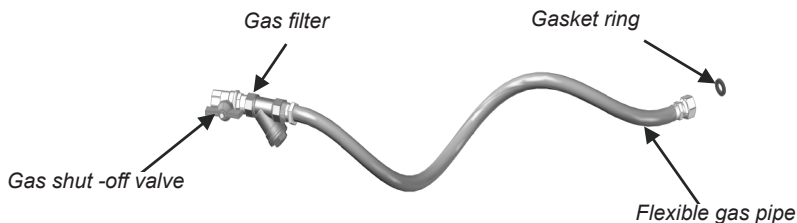

9. picture: Attachment with flexible gas pipe

Attachment of flexible gas pipe has to be directly to the outside threaded gas connection of appliance located on the back side of it.

PERFORMANCE RANGE (mm)	CONNECTING DIMENSION (INCH)
20 - 58	1/2"
68 - 116	3/4"

Works to be performed during gas connection

- Gas pipes clearing

The thorough clearing of gas-supply system is very important before attachment of appliance.

- Gas leakage checking

After installation, of appliance make sure about leak-proof mounting of connections. This action must be fulfilled after every dismantling and assembling!

ELECTRICAL CONNECTION

ATTENTION! Both the fan and the ignition control needs 230V/50Hz mains voltage. Before connecting the appliance to the gas pipe line, please disconnect it from the power line and close the gas valve front of the burner. The appliance must be connected to a grounded power supply system! If the above instructions are not followed that can lead to death, heavy injuries or property damages!

CAUTION

DANGER

CAUTION

ELECTRIC SUPPLY

ATTENTION

COMPULSORY: EARTHING

PLEASE CHECK THE EARTHING!

- The suitable safe operation can not be performed, unless all safety regulations are kept and the equipment properly earthed.
- Whenever an electrical connection is made always the earthing wire should be the longest even in case of cable over stretching the earthing should brake last.

CONNECTION CABLE DATA

- Choosing the right size of cable the maximum amperage, the local regulations and the fact that more than 3% voltage drop is not allowed need to be taken into account.
- Use H05V-K or N07V-K insulated cable suitable for 300/500V.
- All cables need to be lied into a wire tube or channel.
- Cables coming out from the wire tube or channel should not be in tension or twisted. Cables always need to be protected from the humidity. Left cables must only be used for connecting the end section. Check all cable connections.

ELECTRICAL CONNECTION

REGULATORY OPTIONS

2 Point: On (100%) - Off 3 Point: On (100%) - 50% - Off Modulation: On (100%) - Mod (100%...50%) - Off

- Connect the heater electrically according to the attached drawing.



Electrical connection scheme might be changing; we do recommend using the electrical wiring scheme sent with the product

GTV-E-20...107A (AXIAL FAN-TYPE) ELECTRICAL CONNECTION OF 3 POINT REGULATION APPLIANCE WITH HONEYWELL CONTROL BOX AND 5 POLE PLUG

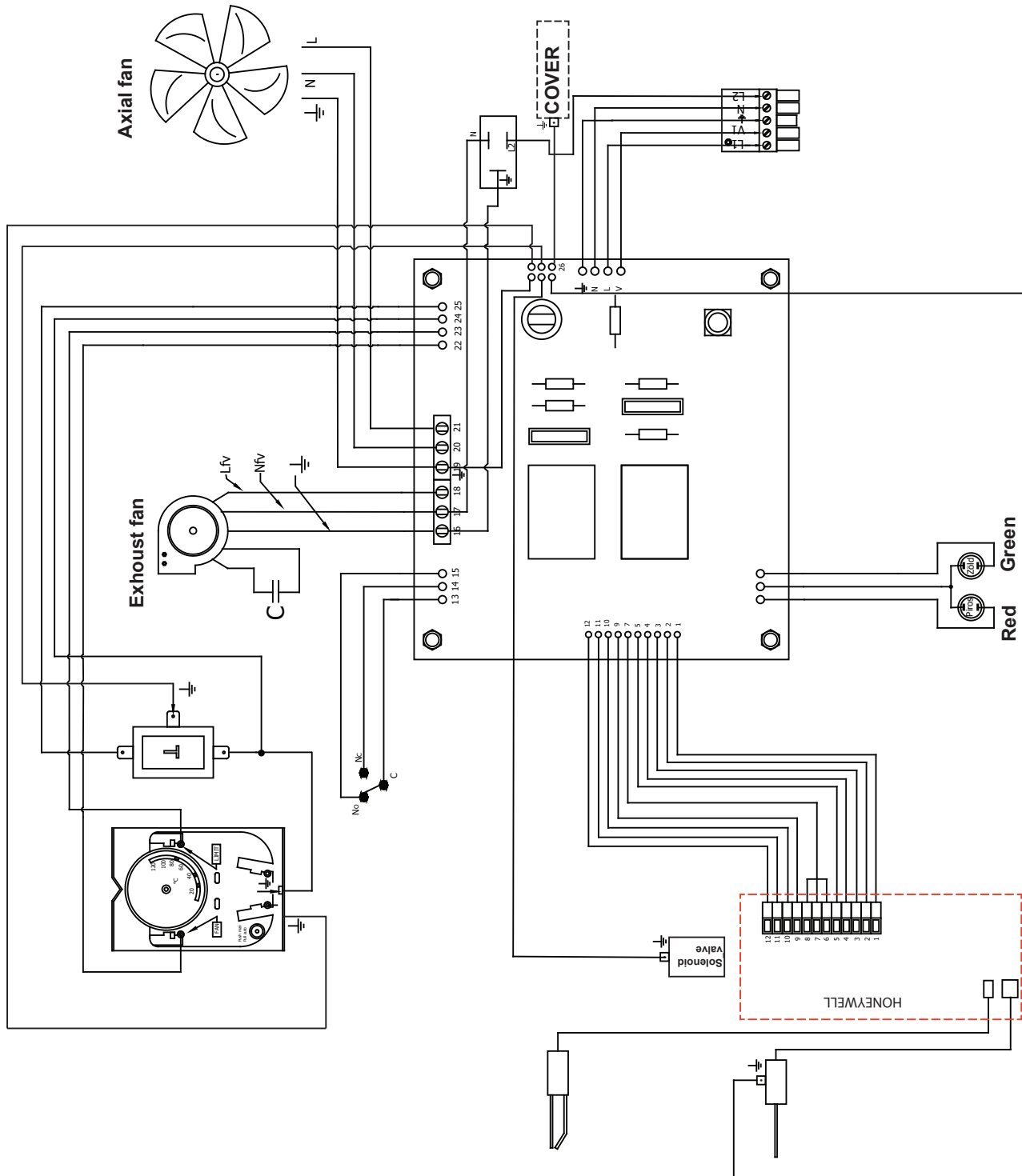

10. picture: Axial fan-type electrical connection of GTV-E appliance with HONEYWELL control box

GTV-E-20...107 A (AXIAL FAN-TYPE) ELECTRICAL CONNECTION OF 3 POINT REGULATION APPLIANCE WITH HONEYWELL CONTROL BOX AND 6 POLE PLUG

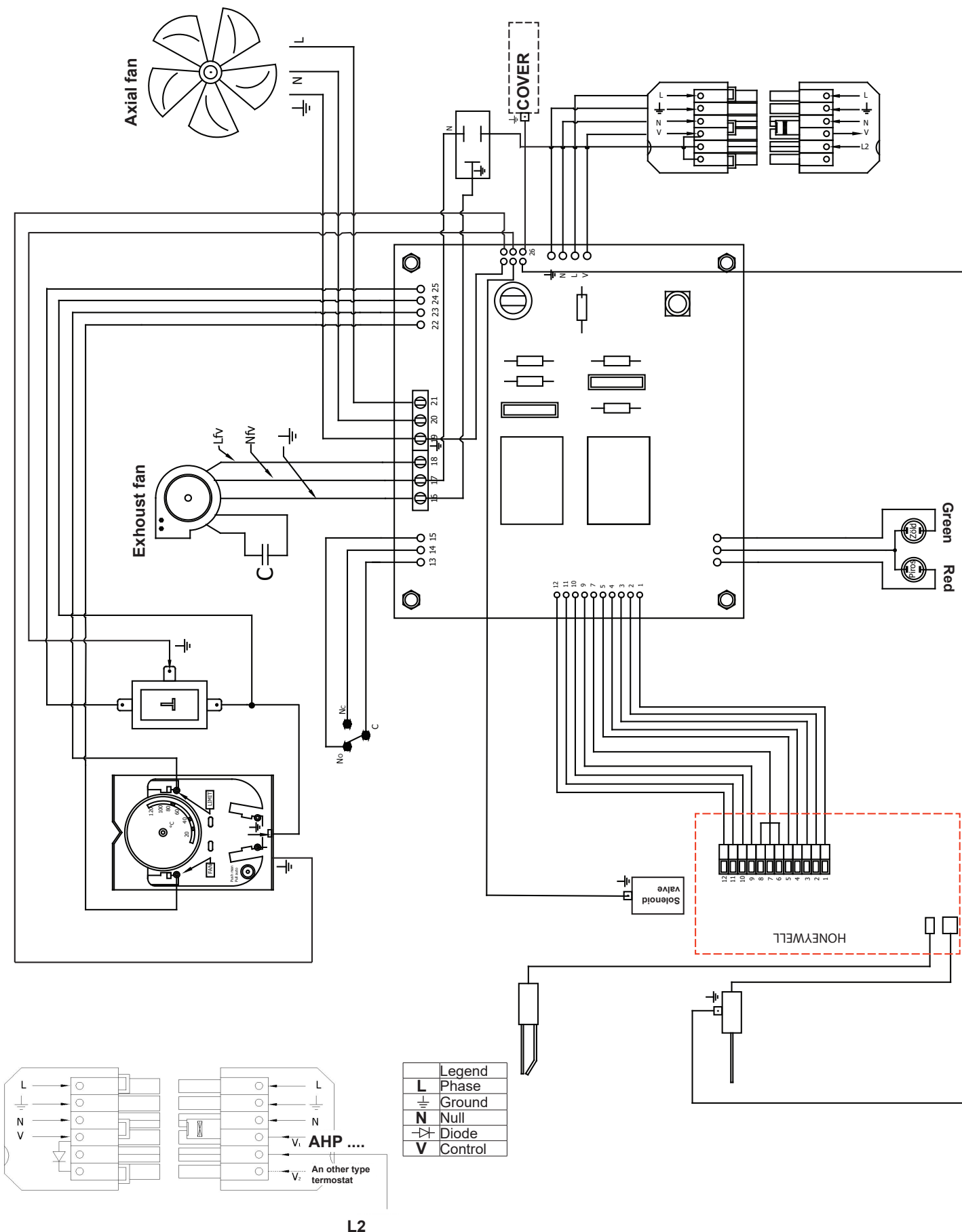

11. picture: Axial fan-type electrical connection of GTV-E appliance with HONEYWELL control box

GTV-E-20...58 A / C / CL (AXIAL FAN-TYPE) ELECTRICAL CONNECTION OF 3 POINT REGULATION APPLIANCE
 GTV-68...107A (AXIAL FAN-TYPE) ELECTRICAL CONNECTION OF MODULATION REGULATION APPLIANCE
 WITH SIT CONTROL BOX AND 5 POLE PLUG

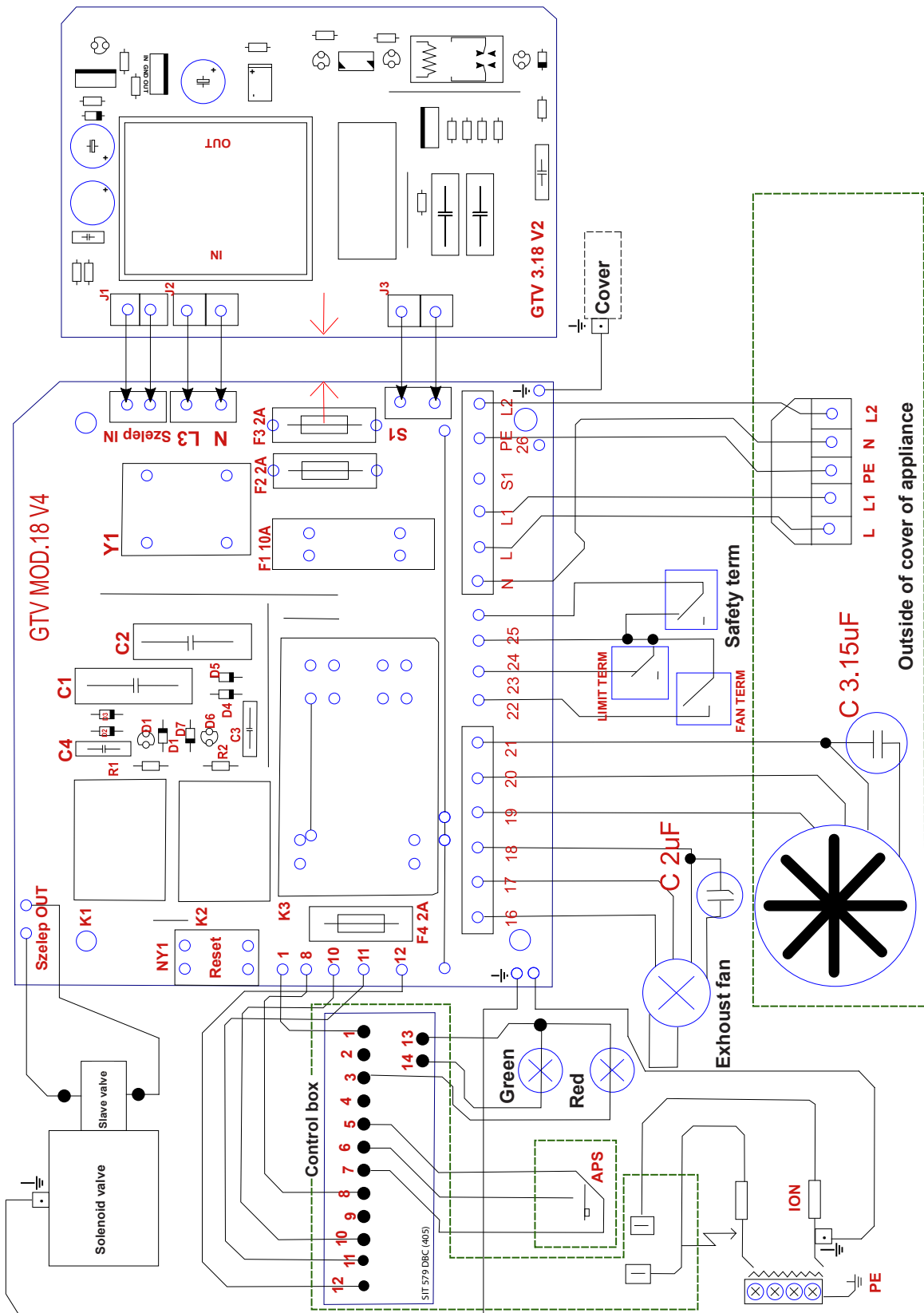

12. picture: 3-point regulation , Axial fan-type electrical connection of GTV-E appliance with SIT control box

GTV-E-20...58 A / C / CL ELECTRICAL CONNECTION OF MODULATION REGULATION APPLIANCE
 GTV-68...107A (AXIAL FAN-TYPE) ELECTRICAL CONNECTION OF MODULATION REGULATION APPLIANCE
 WITH SIT CONTROL BOX AND 5 POLE PLUG

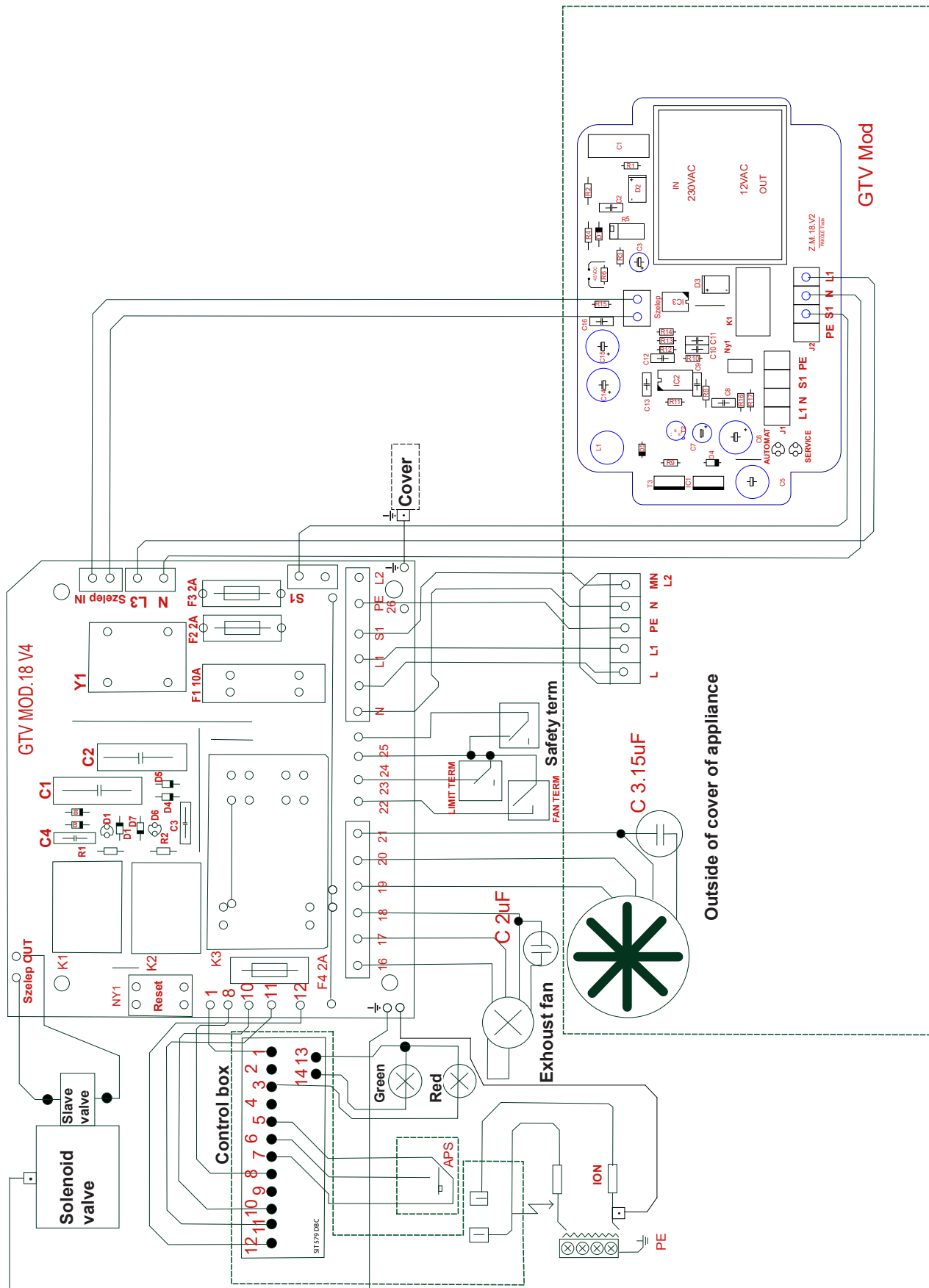

13. picture: Modulation regulation ,Axial fan-type electrical connection of GTV-E appliance with SIT control box

OPTIONAL ACCESSORIES

TEMPERATURE CONTROLLERS

Recommended temperature regulators for appliances:
Please find the description of thermostats in supplied with these



14. picture: AHP-3, AHP-Mod type of thermostat

TYPE OF ELECTRIC SOCKET

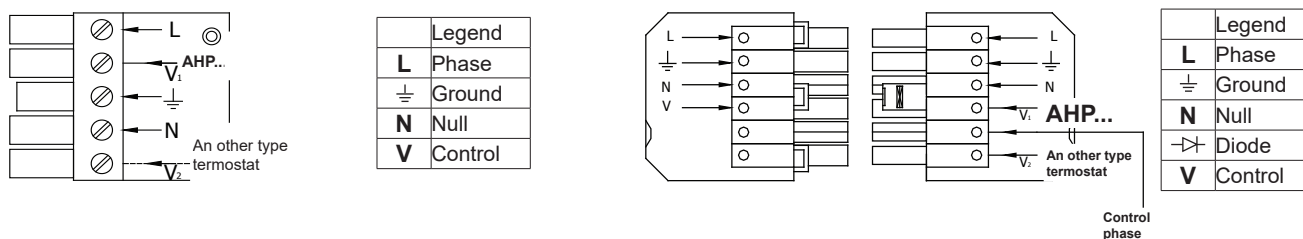

15. picture: Electrical connection for 5- or 6-pole plug

ELECTRICAL CONNECTING SPECIFICATION

The mains fuse should be inactive characteristics-type and for definition of its value take the nominal current consumption - indicated on the data board - of device respectively the quantity of devices moreover in case of bigger distances the length of mains wiring into account.

The mains wire must be installed in the fixed way.(The appliance can not be attached to the mains by plug !)

The proper installation of phase-null wires have to be thoroughly checked !

The appliance has I-class protection against electric shock for this reason it must be supplied with wired protection against electric shock!

The appliance must be operated under dry circumstances.

At electrical installation of appliance the relevant standard must be considered.

For the sake of suitable detachability of appliance from the electrical supply, double-poles – phase / null switching off – detaching main-switch must be installed.

This main switch must be lockable-type in „OFF” position (e.g. by padlock).

In case of specification of the main switch,the nominal current consumption of appliance moreover the instruction of 2014/35/EU must be considered.

REGULATION POSSIBILITIES

APPLICABLE REGULATORY OPTIONS ACCORDING TO REGULATION ECO DESIGN EU2016/426 3-POINT, MODULATION: GTV-E-20...107 kW

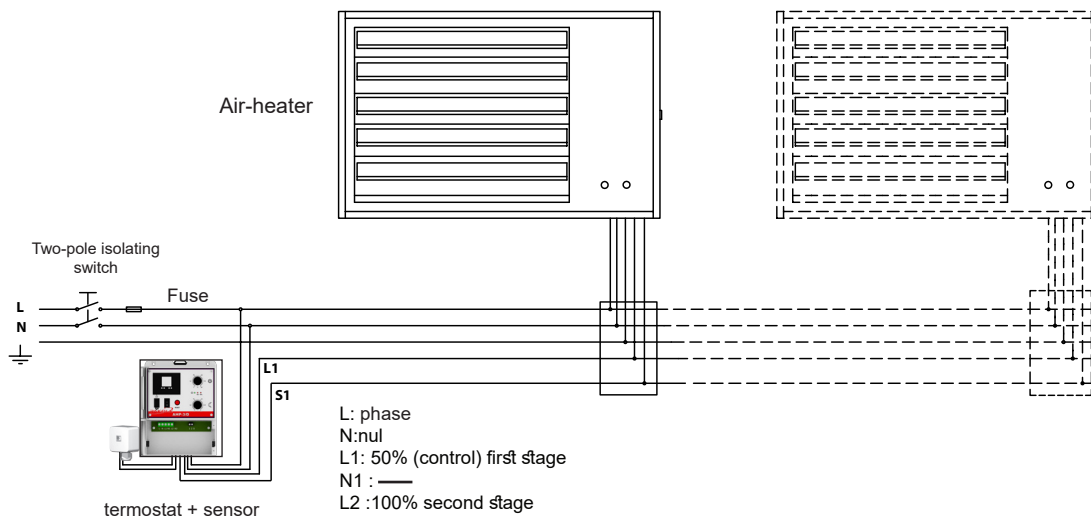

16. picture: Possible regulation mode controlled by AHP-3-type thermostat

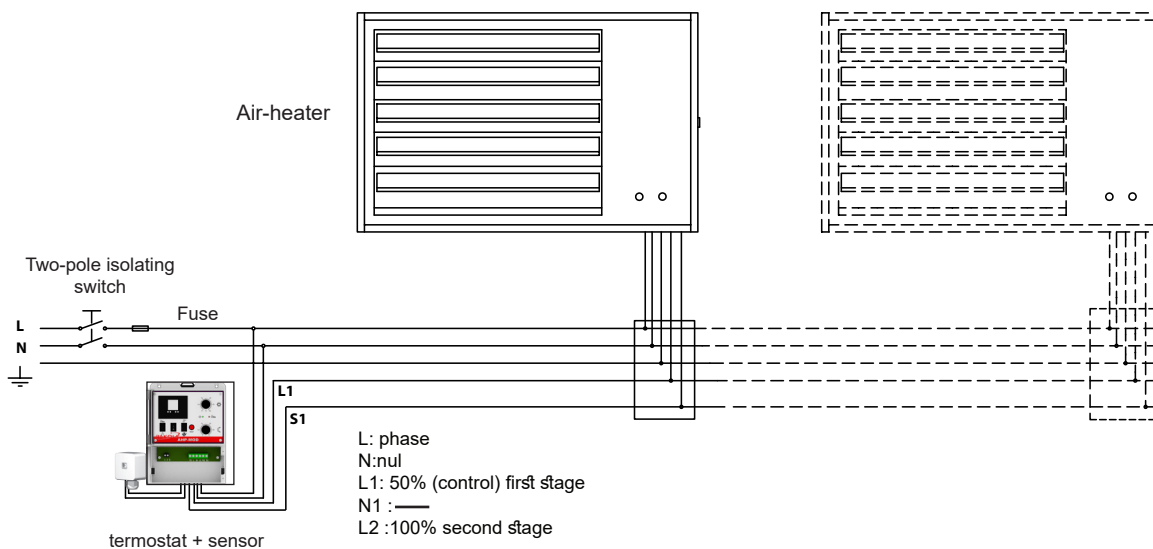

17. picture: Possible regulation mode controlled by AHP-MOD-type thermostat

This type of control is the so-called PILOT control, at which the communication between the programme clock and warm air blower is solved by just one wire namely by „control cable”. The automatic burner control located in the appliance receives and processes the transmitted control signals from the temperature regulator – transmitted by the mentioned control cable – and as a function of these signals starts the requested programme.

6. APPLIANCE SPECIFICATION

VENTILATION

The appliance operates either using of inside air or outside air respectively inside-outside mixed air, which can be sucked in through of located air duct system.

If the appliance uses indoor air than need replace the air by ventilation.

PROTECTIVE DISTANCES

From flammable materials it is obligatory to keep **SAFETY OF OPERATION** and **FIRE PREVENTION** distances!
 Minimal dimensions of protective distances:

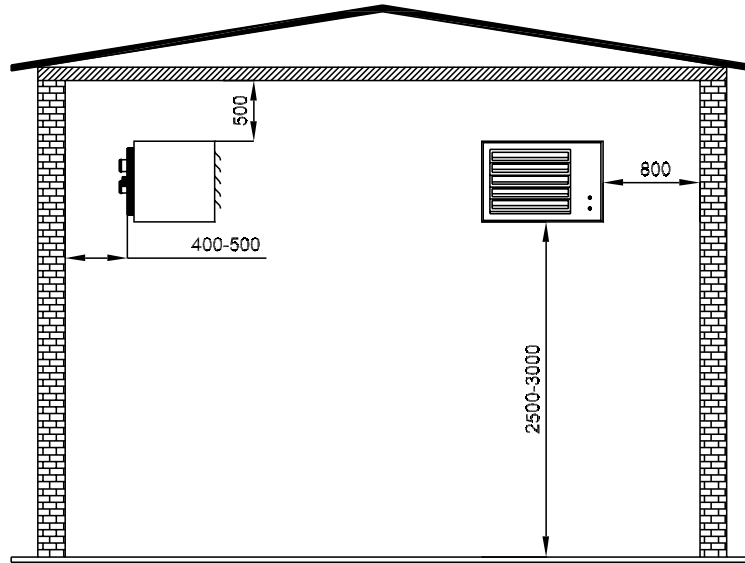

18. picture: Protective distances

7. FIXING AND EXHAUST SYSTEM POSSIBILITIES

FIXING POSSIBILITIES

LOCATION ON CANTILEVER

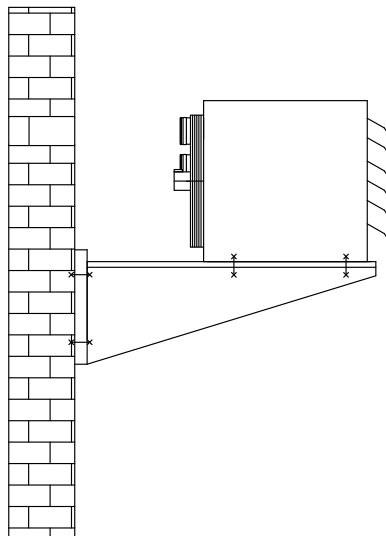

Located on cantilever

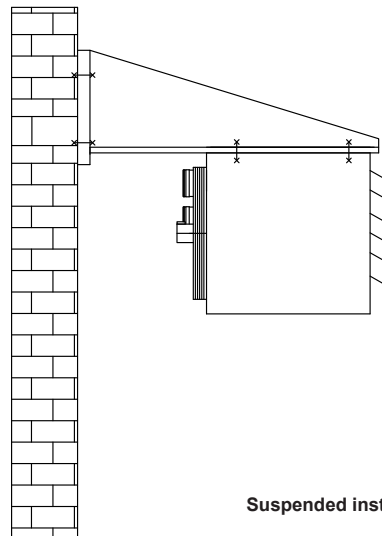

Suspended installation

19. picture: Fixing possibilities

CANTILEVER DIMENSIONS

(The cantilever can be purchased from the manufacturer for installation.)

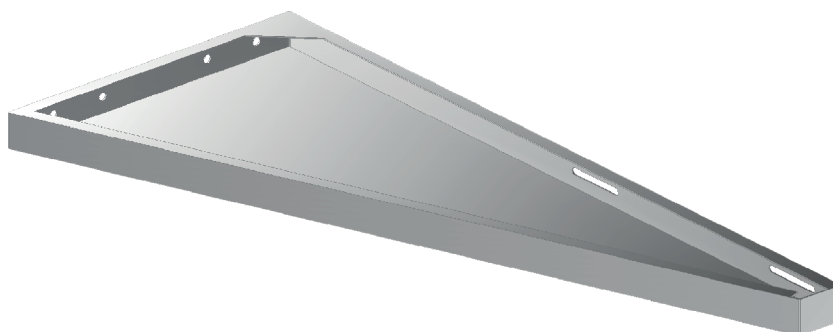

20. picture: Cantilever

CANTILEVER DIMENSIONS AT GTV-E 20-58KW APPLIANCES:

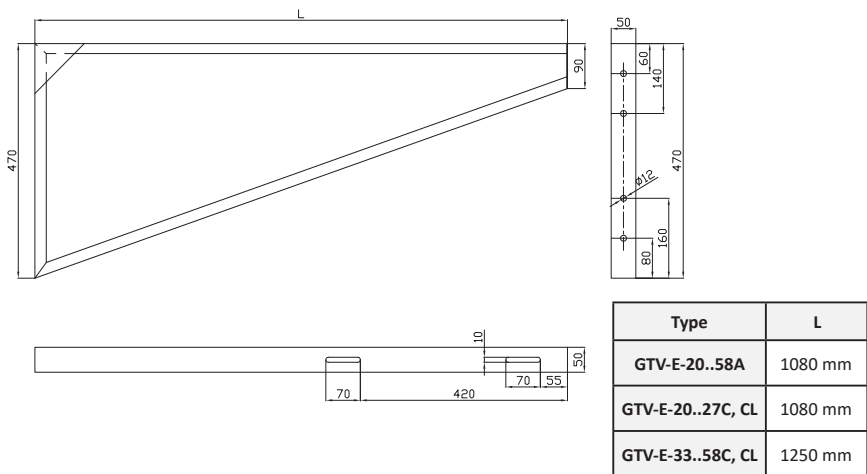

21 picture: Cantilever dimension

CANTILEVER FIXING POINTS (GTV-E-20....58KW)

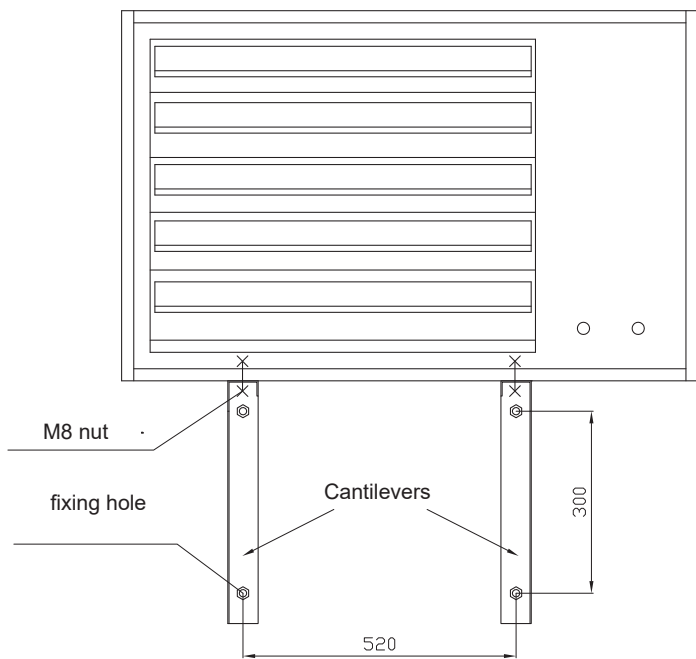

22. picture: Fixing point

The cantilever can be mounted to the wall by its fixing points . (4 pcs/pair)

Take the following into consideration:

- in case of appliance power up to **max. 58kW** the proposed mounting solution is the using of tightening-wall plug type **M10/100** for cantilever fixing
- in case of cantilever-type fixing solution **above appliance power 58kW** the using of tightening-wall plug is not enough because of weight of appliance for this reason **it is proposed drilling through of wall and mounting with over-lap.**

WARNING! Before installation of appliances between 68-107kW the STATIC investigation of walling is in any case needed!

Proposed installation mode above 58kW:

- drilled through wall **with overlap**,
- mounting of so- called „resting column” under the end of cantilever,
- **placing on stand frame** (e.g. in case of prompt structure building),
- **suspension by wire-ropes.**

The appliance can be mounted on the fixed cantilevers by lengthwise grooves. These grooves make the suitable fixing possible ensuring the minimum fire protection distances.

The fixing of appliance to the cantilever can be executed by 4 pcs **M8x25 5.6** screws or M8 threaded rod. There are 4-4 pcs riveted M8 nut on top and bottom side of device.

WARNING! During the installation of appliance lockwasher has to be mounted under locknuts, threaded rod and screws!

SUSPENSION-TYPE INSTALLATION

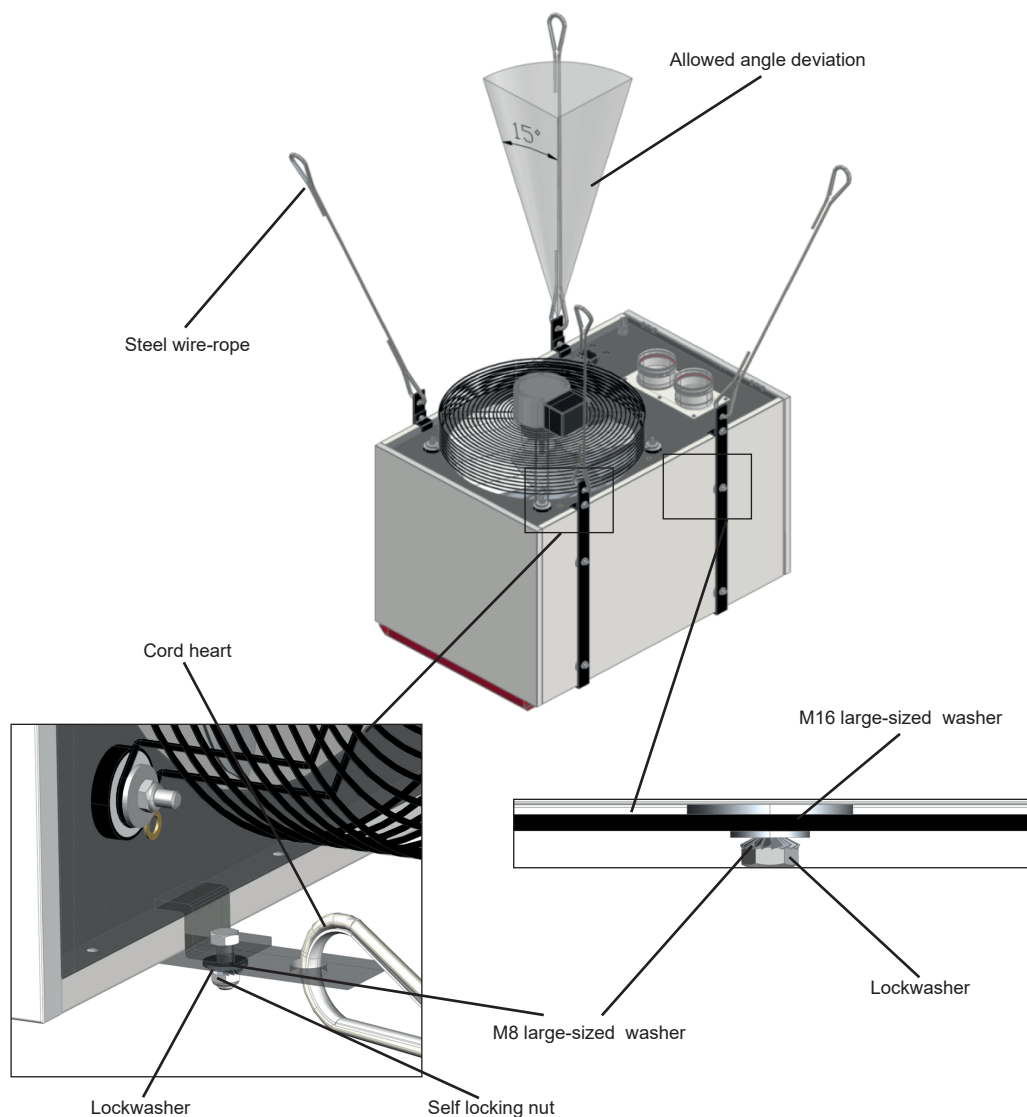

23. picture: Fixing by steel wire-rope

In case of steel wire-rope mounting the following instructions have to be kept in any case:

- during operation of appliance the arising vibrations can result in loosening of screwed joints at suspension points of structure for this reason in order to avoid this problem **lockwasher and plastic-inserted self locking nut must be mounted.**

Further instructions:

- between the riveted nuts and bracket plates be **M16 large-sized washer**,
- the screws be mounted with **M8 large-sized washers**,

specifications for used steel wire-rope:

- the load capacity of steel wire-rope be at the least 200kg per rope
- application of cord heart is obligatory in any case!

EXHAUST SYSTEMS

Exhaust system units



1. Perpendicular roof exit (flue/combustion air) set C32K
2. Side-wall exit (flue/combustion air) set C12K
3. Straight unit 250/500/1000mm
4. 90° elbow
5. Set B23 for flat roof or side-wall exit
6. Flue end unit B22/C12K
7. Combustion air sucking end unit C12K
8. Rubber bell (for slanting roof B23)

24. picture: Exhaust system units

The appliances can only be installed by such dimensions and material of combustion air supply and flue systems, which are specified by appliance manufacturer.

The allowable flue lengths and pressure drops can be found in the **enclosure 3**.

TYPES OF EXHAUST SYSTEM

B22H TYPE

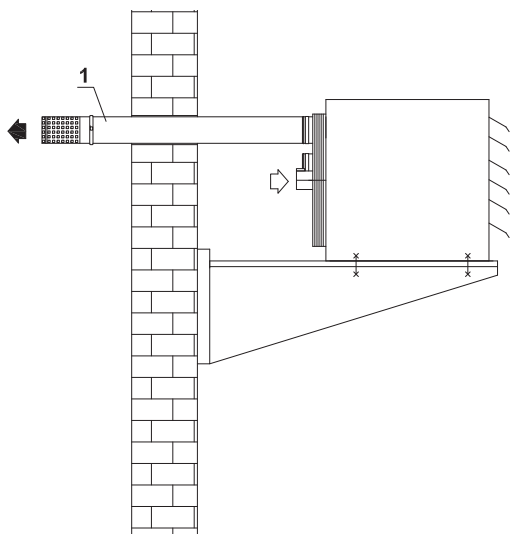

The combustion air supply is directly from the heated area and flue system Ø100mm is horizontally across the wall to outside.

Components:

- horizontal flue terminal
- clamp
- flue pipe 1m

It is possible to extend the flue pipe with the following components:

- clamp
- flue pipe 250/500/1000mm length (Ø100mm)

The flue pipe is not insulated for this reason during installation insulation has to be placed around the pipe between the pipe and wall!

25. picture: B22H type horizontal execution

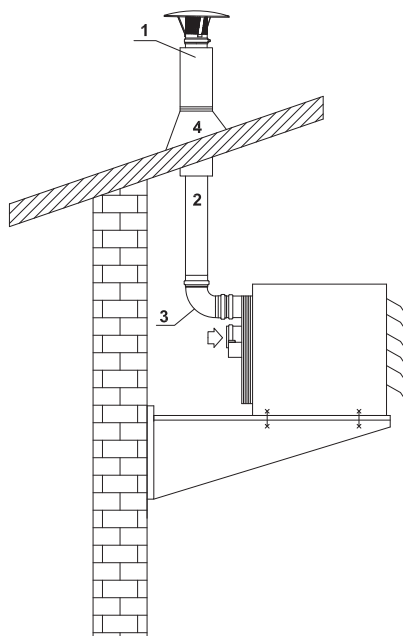

B22V type

The combustion air supply is directly from the heated area and the flue system Ø100mm is vertically across the roof to outside. The outside flue pipe is insulated Ø150/100mm.

Components::

- vertical flue roof terminal,
- flue pipe 250/500/1000mm (Ø100mm),
- elbow 90° (Ø100mm),
- rubber sealing.

26. picture: B22V type vertical execution

It is possible to extend the flue pipe with the following components

- clamp,
- flue pipe 250/500/1000mm length (Ø100mm)

C12K TYPE COAXIAL

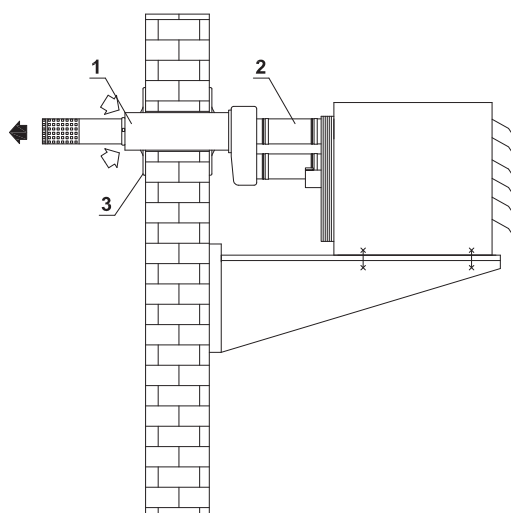

The combustion air supply and flue system is horizontally-coaxial solution-across the wall to outside.

Components:

- horizontal wall terminal (fume/air coaxial pipe)
- flue pipe 250/500/1000mm length(Ø100mm)

outlet diameters: Ø100/150mm

The pipes can be extended or shorted with different components. The coaxial terminal can be removed from the appliance with pipes: 250/500/1000mm length and clamps.

27. picture C12K type coaxial execution

 **ATTENTION! This kind of execution is not available in case of appliance power between 68-107kW!**

C12 TYPE

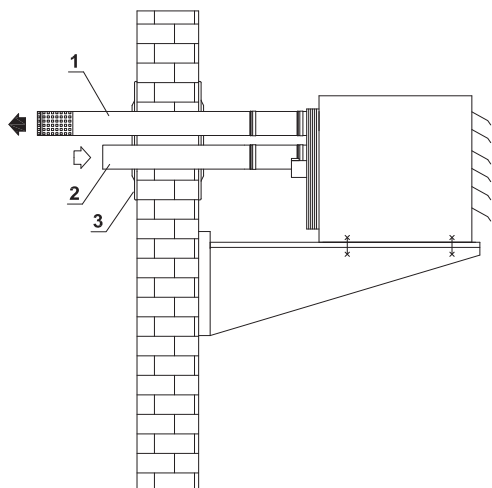

28. ábra: C12 type horizontal execution

The combustion air and flue system is horizontally across the wall to outside

Components:

- flue pipe: 250/500/1000mm (Ø100mm),
250/500/1000mm (Ø100mm),
- air supply pipe: 250/500/1000mm (Ø150mm),
- cover (optional)

The pipes can be extended or shorted with different components

- pipes 250/500/1000mm length
- clamps

C32K TYPE

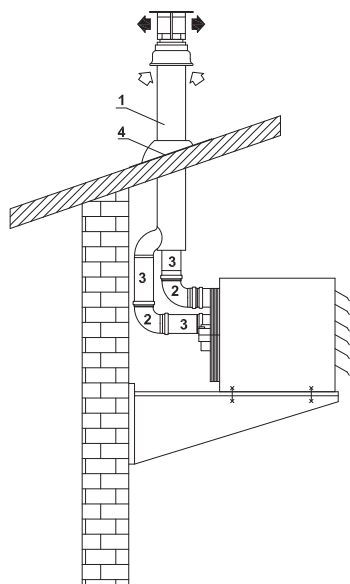

29. ábra: C32K type vertical execution

The combustion air supply and flue system is vertically-coaxial solution- across the roof to the outside.

Components:

- vertical roof terminal (fume/air coaxial pipe)
- elbow 90°(Ø100mm)
- 250/500/1000mm (Ø100mm)
- rubber sealing(traight or slanting)

The pipe diam. above the roof 100/150mm

The pipes can be extended or shorted with different components.

The coaxial terminal can be removed from the appliance with pipes: 250/500/1000mm length and clamps



ATTENTION! This kind of execution is not available in case of appliance power between 68-107kW!

C52 TYPE

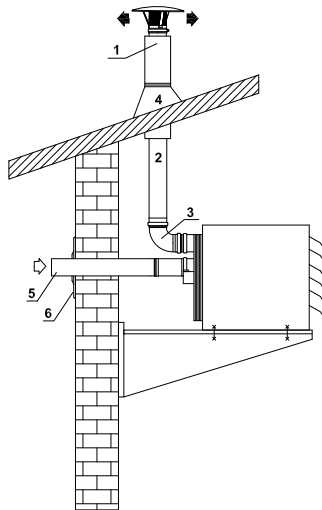

The combustion air supply is across the wall from outside, the flue system is vertically across the roof to outside with 100mm pipe. The pipe diam. above the roof is 150/100mm.

Components:

- vertical roof terminal
- flue pipe 250/500/1000mm (Ø100mm)
- elbow 90° (Ø100mm)
- rubber sealing
- air supply pipe 250/500/1000mm (Ø150mm)
- cover

The pipes can be extended or shorted with different components:

- pipes 250/500/1000mm (Ø100mm)
- clamps

30. picture: C52-type execution

MINIMAL DISTANCE OF THE AIR SUPPLY AND VENTING SETS

THE COMBUSTION AIR SUPPLY AND FLUE SYSTEM IS VERTICALLY-COAXIAL SOLUTION- ACROSS THE ROOF TO THE OUTSIDE AT B22 TYPE.

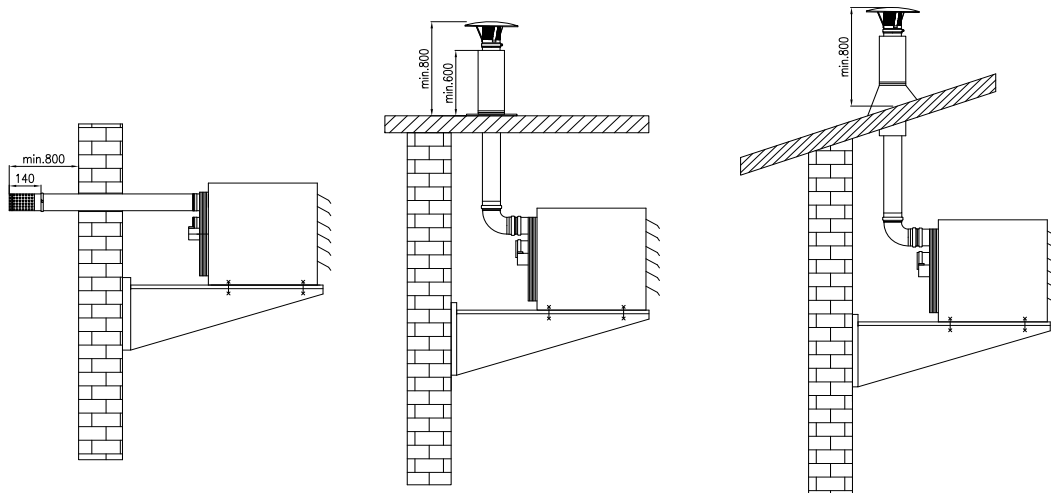

31. picture: Minimal distances at B22 type

THE MINIMAL DISTANCE OF THE FLUE AND AIR SUPPLY SYSTEM FROM THE WALL AT C12K TYPE

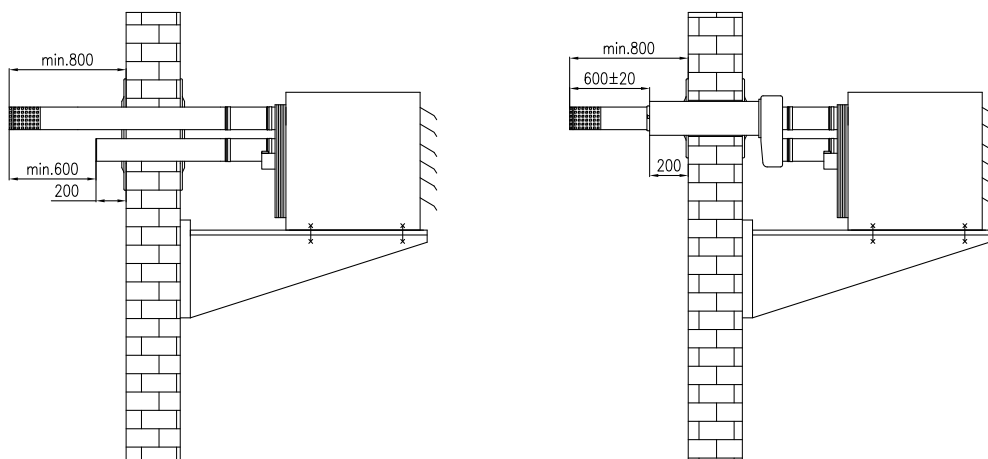

32. picture: Minimal distances at C12K type

THE MINIMAL DISTANCE OF THE FLUE AND AIR SUPPLY SYSTEM FROM THE ROOF AT C32 TYPE

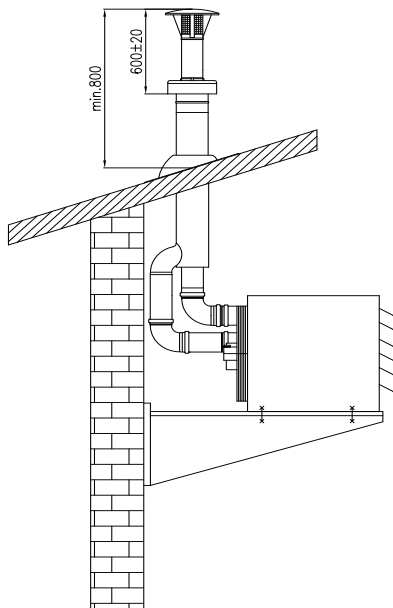

33. picture: Minimal distances at C32 type

8. ACCESSORIES

These components are optional accessories of GTV-E-CL-type appliances according to the Fig 30/a,b. If you would like to purchase these air duct components, please contact with sales section of PAKOLE TRADE Ltd.

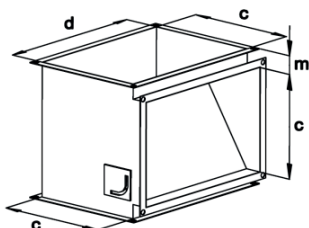

T form with „winter-summer“ mode relay (TIK...)

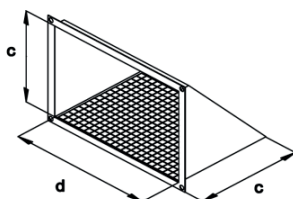

Outside air sucking form with bird protector grid (KLM...)

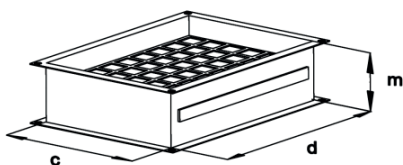

Filter keeping with filter (SZTS...)

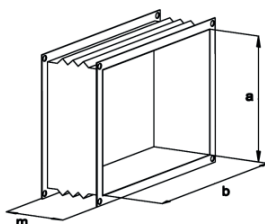

Vibration damper (RT...)

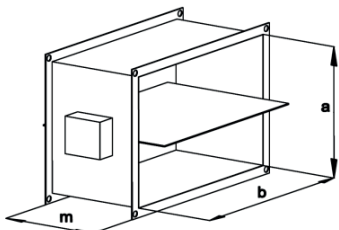

Fire damper (TCS...)

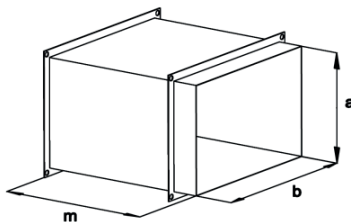

Adjustable straight air channel section (AEL...)

Type	Marking (mm)			
	a	b	c	d
GTV-E-20...27 A / C / CL	350	600	350	500
GTV-E-33...40 A / C / CL	500	600	400	550
GTV-E-48...58 A / C / CL	650	600	450	600

Type	Marking (mm)
	m
TIK...	50
KLM...	-
SZTS...	150
RT...	160
TCS...	a
AEL...	500

34. picture: Air duct components

9. APPLIANCE OPERATION

START, RESTART

The properly installed appliance according to the control sign received from temperature regulator - in the present case heating – starts the exhaust fan, which executes the 30 seconds pre-purge time. This time period is also enough for biggest power appliance to ensure the satisfactory air exchange namely the triple of combustion air volume. When the ventilation happened the sparking is started and the dual magnetic valves are opened the gas ignites.

If the continuous burning is formed within 5-10 seconds the appliance is operating normally the green control lamp is lighting. During operation the appliance continuously monitors the status/sign of differential pressure switch and flame detector, if needed the electronic control intervenes in the process.

If the status of differential air pressure switch is changed during operation namely switches over from work/switched on position to basic/standstill position in that case the automatic electronic control stops the gas supply by closing of magnetic valves and controls the appliance in error mode moreover the red control lamp located on front side of device is lighting.

In case the flame detector of automatic burner control does not sense flame formation during ignition in that case stops the gas supply and controls the appliance in error mode moreover the red control lamp is lighting.

In case during burning process the pressure difference decreases under the permissible minimal value on the air pressure switch than the automatic control prohibits the operation as follows:

- stops the gas supply
- stops the operation of exhaust fan
- controls the appliance in error mode and red control lamp is lighting



ATTENTION! The restart of appliance, which is in safety status can only be possible by pushing of „RESET” push button located on the PCB (inside of appliance) or on the temperature regulator!

General information: The flame detector is self-checking and can just operate with the burner, other environmental effects (ambient temperature, lights) can not influence it.

CONTROL AND REGULATION OF APPLIANCE

The control of appliance is performed by temperature regulator (room thermostat). It can be manually operated or equipped with programme-clock according to the request.

AHP-3:

The appliance is controlled by a HEATING/0/COOLING selector and RESET button. It has a time switch. Use the two rotatable knob to set the temperature. Thermostat can TURN ON and TURN OFF the appliance, it depends on the room temperature. You have a chance daily and weekly programming with time switch.

Thermostat and appliance: Appliance is under voltage with selector. In this case the green lamp is lighting and you can chose from heating or cooling mode.

Operation:

In heating mode, use the knob to set the maximal pressure (2 red lamp is lighting) and after turn the button back (50 % LED is lighting) to set the minimal pressure. Next step to set required temperature with the knob.

AHP-MOD:

Controller has HEATING / 0 / VENTILATION switch, „RESET” button, MODULATION/100% switch and has PROGRAM HOURS. Set day and night temperature by two calibrated rotary knobs. The programmable thermostat turn on device depending on the time of day if required by the room temperature.

Set control device: turn on the device by switch 0/1 (green LED lights up) Turn on HEATING by HEATING / VENTILATION mode switch.

Setting mode: In heating mode set the knob to 30°C then the device working at 100%. Set the solenoid valve at maximum upper pressure. Turn back the knob until red LED flashes. Check out the output voltage S1 and L1 between 110V and 115V. Set the solenoid valve at minimum pressure. After that set the room temperature value.

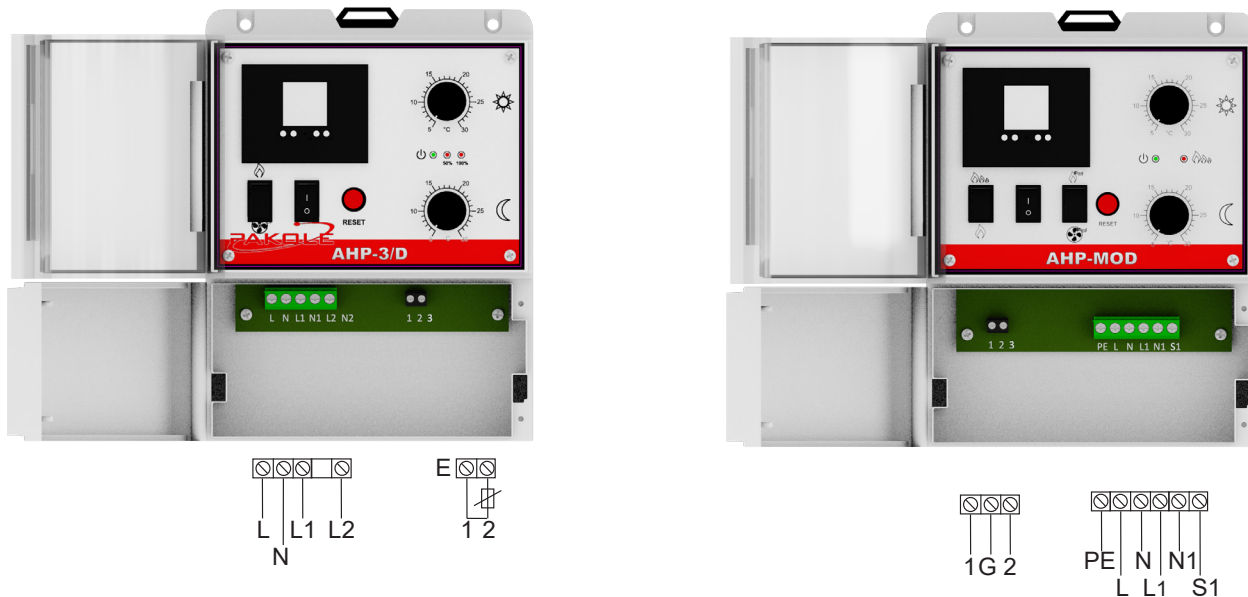

35.picture: AHP-3 and AHP-MOD temperature regulator

ATTENTION! The GTV-E warm air blowers can be operated by AHP-3 and AHP-MOD-type temperature regulator, which may be purchased at appliance manufacturer . In case of using different temperature regulator, please contact with the manufacturer in interest of proper installation!

10. MAINTANCE

The GTV-E-type warm air blowers apart from the checking of suspension and cleaning of cover, lamella and circulating fan do not need extra maintenances but to be able to preserve the long lifetime of appliance it is recommended to have yearly supervision done with a qualified service or expert.

MAINTENANCE PROCEDURES

Maintenance supervisions by the customer: (recommended half a yearly)

- supervision of circulating fan, if needed clean it (by high pressure air),
- supervision of out-blowing apertures (lamella)
- supervision of suspension points/surfaces by survey



WARNING! Before every maintenance the appliance must be detached from the electrical supply by switching off the main-switch and disconnecting the connection plug located on the back side of appliance!



ATTENTION! In case operational circumstances of appliance (atmosphere is contaminated with corrosive substances,dirt) need it, then supervision and cleaning may have done more often! The main reason of this that dirt placed on the fan may damage efficiency of appliance!

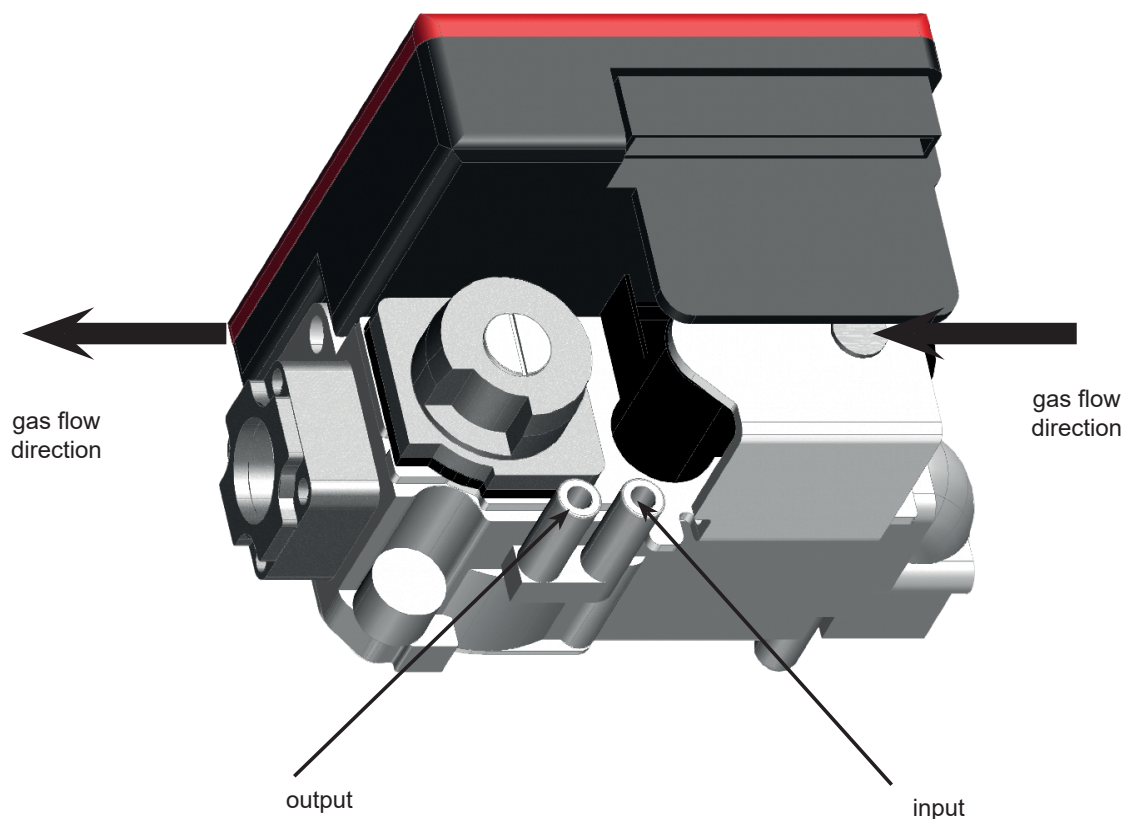

36. picture: Gas pressure check with HONEYWELL magnetic valve

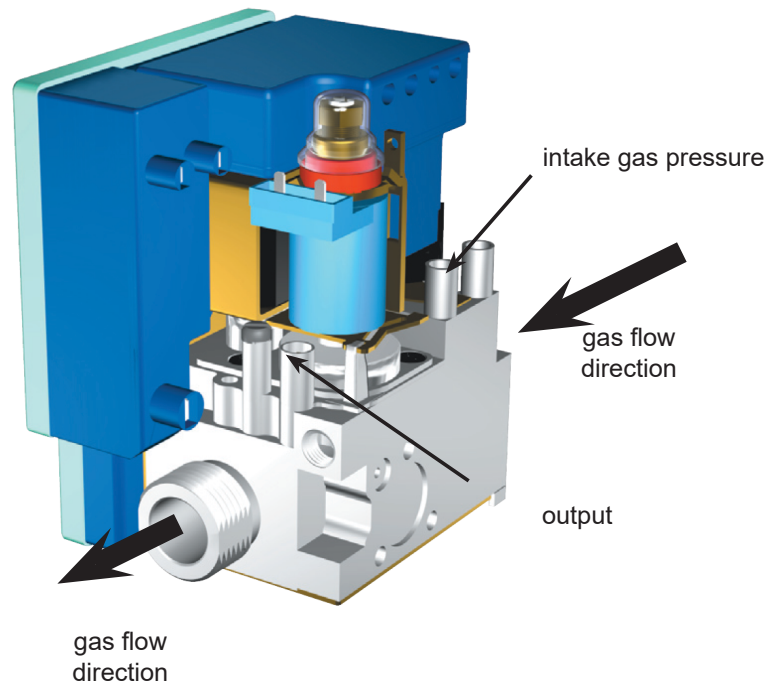

37. picture: Gas pressure check with SIT magnetic valve

**MAINTENANCE SUPERVISION SOLELY BY A QUALIFIED SERVICE DEPARTMENT
(ALL KINDS OF INTERVENTIONS FOR WHICH DISASSEMBLY OF APPLIANCE IS NECESSARY):**

- supervision of nozzle pressure (at the outlet of solenoid valve),
- check of the condition of pressure regulator
- check of the protective ground
- check of the electrical connection
- check of the exhaust fan and circulating fan: check the free rotation of fan and remove the possible contaminations from the impellers
- supervision of the heat exchanger
- supervision of working of the temperature controller
- check of the ignition and ionization electrode, if necessary change it
- check of the exhaust fan and circulating fan, if necessary clean those
- supervision of the quality of combustion
- dismantling and clean of the gas filter by high pressure air



ATTENTION! After every maintenance the appliance must be again adjusted !

Constructional components, which ensure the suitable operation:

- double-closed solenoid valve
- automatic burner control
- electrical board (sign processing)
- differential pressure switch
- exhaust fan
- combined thermostat (bimetal),
- heat-limiter thermostat (100 °C),
- circulating fan

Apart from cleaning of exhaust fan and circulating fan the a.m. components do not need maintenance! The cleaning of fans is expedient to carry out by high pressure air.



**WARNING! Never block the outflow of fume and inflow of combustion air!
Never change the original adjustments what the expert made!
Never allow that water or water -vapour can be got on the appliance!**

GAS CHANGE

ATTENTION! In case you would like to operate your appliance by another type of gas(e.g. by Natural gas instead of Propane gas), then contact the local authorized representative or a qualified service department!

PROCESS OF NOZZLE EXCHANGE

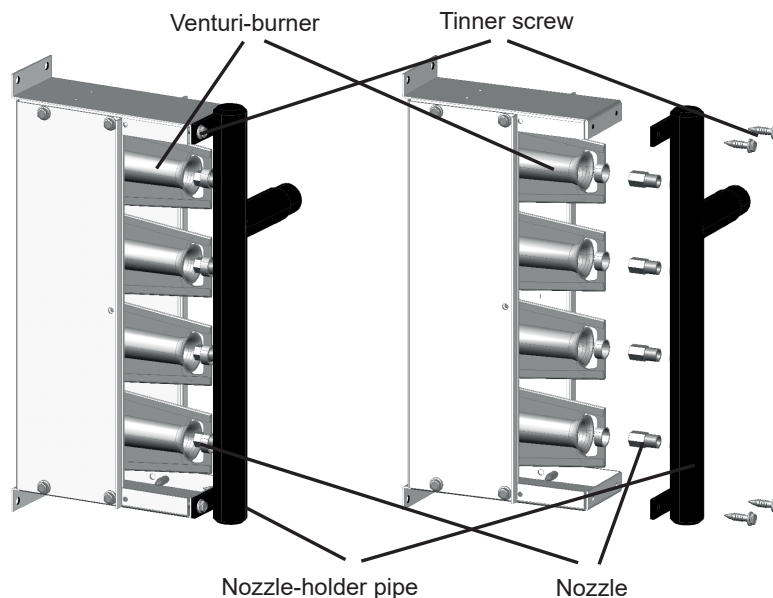

38. picture: Disassembly of burner

- disconnect the electrical and gas supply
- take off the solenoid gas valve from the nozzle holder pipe
- take off the 4pcs tinner screws from nozzle holder pipe
- take off the nozzle holder pipe from the burner
- unscrew the nozzles (NPT threaded)
- clear the threads if necessary
- screw in the new nozzles
- put the nozzle holder pipe back to the venturi-burner
- fix it by 4pcs tinner screws
- mount the solenoid valve on the nozzle-holder pipe

EXCHANGE PROCESS OF NARROWING PLATE (UNDER EXHAUST FAN)

- disconnect the air and gas supply
- take off the wiring of exhaust fan from electrical board
- take off the silicon pipes of differential pressure switch
- disconnect the flue system from the exhaust fan (taking off 4 pcs. M4 nuts),
- pull out the flue tube from device
- take off the nuts from the exhaust fan
- take off the exhaust fan
- take off the heatproof insulator sheet
- take off the narrowing plate
- put in the new narrowing plate (the relevant data of narrowing plates is in the enclosure 5)
- put back the heatproof insulator sheet
- put back the exhaust fan
- fix the nuts of device
- fix the flue system to the connection of exhaust fan
- put back the silicon pipes of differential pressure switch (take care of proper/original position)
- connect the wiring of exhaust fan to the electrical board

MAINTENANCE OF REGULATION SYSTEM OF APPLIANCE

Combined regulator thermostat assembled with the appliance ensures the suitable operation of device.
 Combined thermostat: 3 positions (*Honeywell - L4064*):

- **FAN OFF** – stops the fan – depending on the adjusted temperature.
- **FAN ON** – starts the fan – depending on the adjusted temperature
- **LIMIT OFF** – stops the operation of burner – depending on the adjusted temperature a

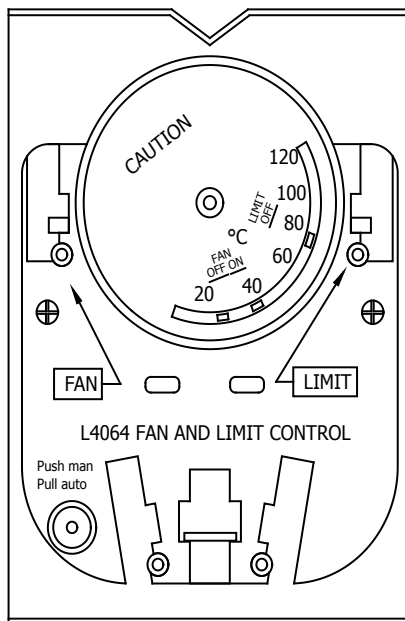

39. picture: Combined regulator thermostat

The bimetal spring of the thermostat is placed in between the pipes of heating exchanger . It regulates the working of burner and circulating fan during operation. After start the burner works and when the temperature reaches the adjusted value on the thermostat (FAN ON) the fan starts to work. In this case the burner and fan is working together. If the temperature reaches the LIMIT OFF value than the thermostat switches off the burner but the fan is working on. As soon as the temperature decreases under the LIMIT OFF the electronic control starts the burner again

The values of the combined thermostat is adjusted by the manufacturer so not necessary to modify the values! Only authorized expert or service can change the adjusted values!

Temperature limiter thermostat (RESET thermostat,located next to the combined regulator thermostat) - Switch off the burner in case of overheating(100 °C). In this case – after cooling down – the restart can only be possible by pushing of the "RESET" switch located on the thermostat. This action can only be realized by authorized expert or service!

Expect emergency it is prohibited to disconnect the electrical supply of appliance during operation, because in this case the appliance can be overheated and the exchangers can be burned out. At electrical supply cut, the heat exchangers can little be overheated in case this temperature reaches or surpasses the 100 °C the mechanical temperature limiter thermostat switches on. In such a case the restart can be realized by pushing of RESET button located on the thermostat.

 **ATTENTION! This action can only be realized by qualified expert or service!**

 **ATTENTION! If the heater appliance is working, than it is prohibited to close the shutters completely!**

11. TROUBLESHOOTING

There are installed mode indicator lamps on the front side of appliance:

- GREEN: operation indicator lamp
- RED: error indicator lamp

THE APPLIANCE DOES NOT START

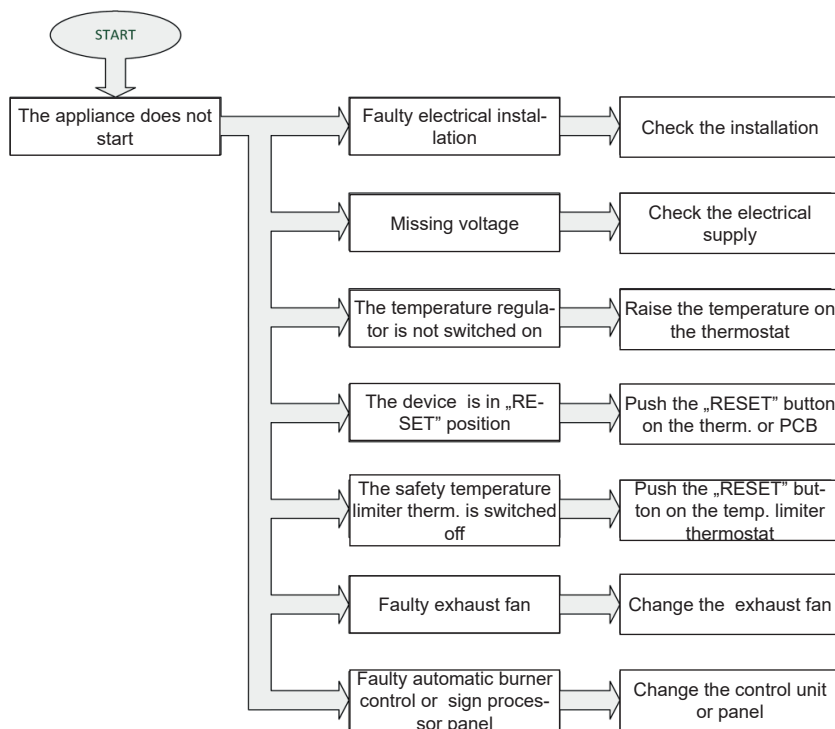

THE APPLIANCE OPERATES CONTINUOUSLY

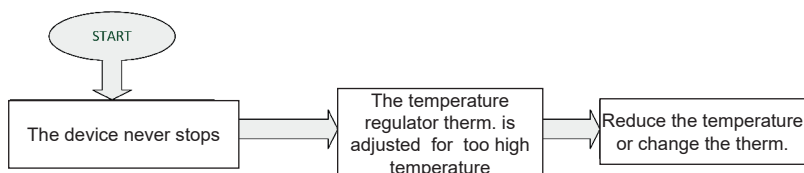

THE APPLIANCE JUST PREPURGES

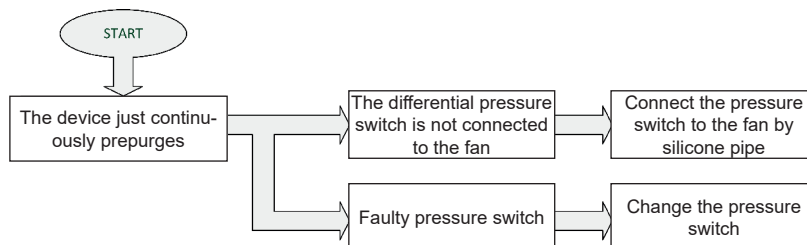

THE APPLIANCE JUST PREPURGES

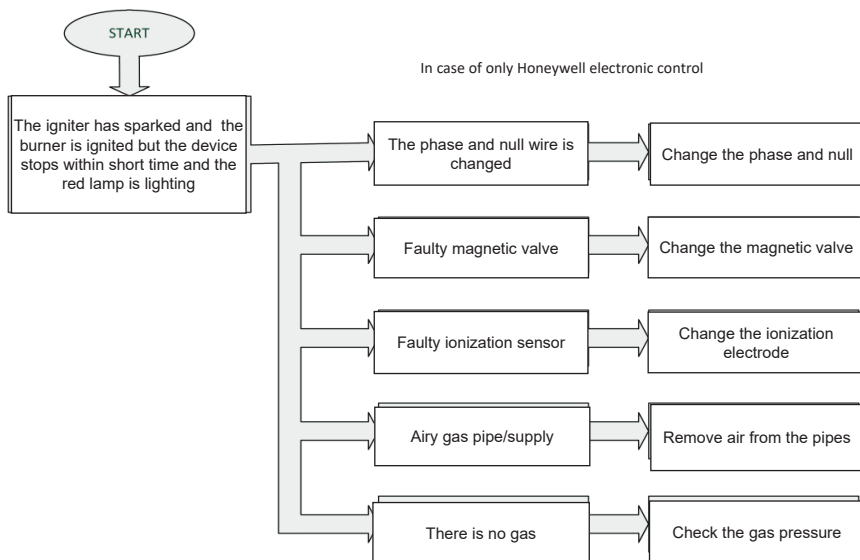

THE APPLIANCE SWITCHES OVER TO SAFETY POSITION

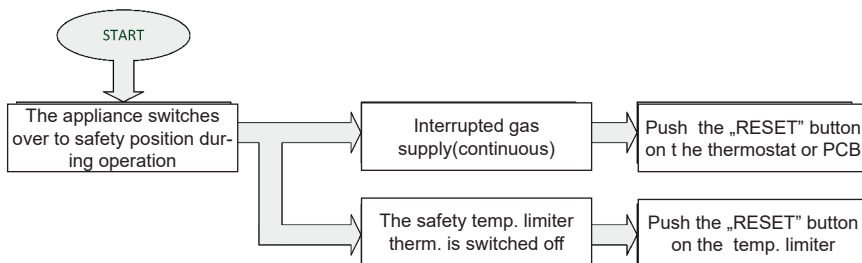

AT STARTING COLD AIR IS FLOWING

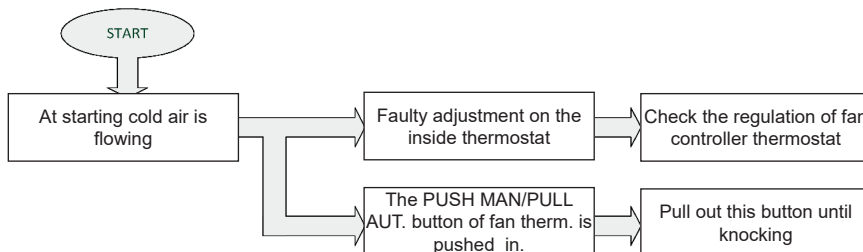

THE APPLIANCE HEATS INSUFFICIENTLY

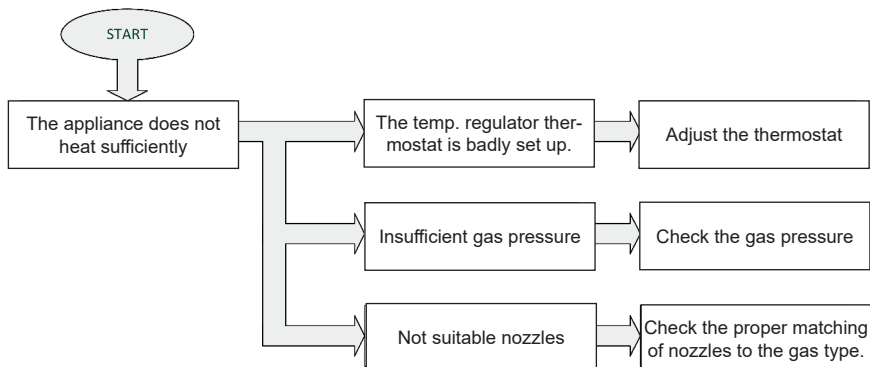

INCREASE OF VALUES OF CO (>200PPM)

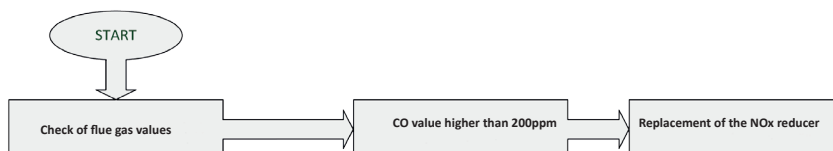

12. ENCLOSURE

ENCLOSURE 1 / A . : APPLIANCE PERFORMANCE DATA

TYPE		GTV-E-20A	GTV-E-27A	GTV-E-33A	GTV-E-40A	GTV-E-48A	GTV-E-58A
INPUT POWER(NCV)	kW	21,16,6	25,8/20,4	34,1/26,9	39,6/31,3	48,8/38,6	58,6/46,3
OUTPUT POWER (NCV)	kW	19,4/15,2	23,9/18,7	31,5/24,6	36,7/28,7	45,1/35,3	54,2/42,3
EFFICIENCY [3 POINT,MOD]	%	72,6/73,1	72,8/73,3	72,2/72,6	72,3/72,7	72,2/72,7	72,1/72,9
AIR FLOW	m ³ /h	2520	3110	3720	4490	5480	6410
QUANTITY OF FAN	pcs	1	1	1	1	1	1
DIFFERENT OF AIR TEMPERATURE ΔT	°C	24,1	24,9	24,5	24,7	25,2	25
AIR THROW	m	12	16	18	20	22	25
EXHAUST PIPE / AIR SUPPLY DIAMETER	mm	Ø100/Ø100					
GAS CONNECTION		G1/2" ISO 228 OD					
ELECTRICAL CONNECTION		230V / 50Hz					
NOMINAL CURRENT CONSUMPTION	A	0,9	0,9	1,77	1,77	1,9	1,9
ELECTRICAL PERFORMANCE	kW	0,21	0,21	0,41	0,41	0,44	0,44
NOISE LEVEL	dB(A)	53	53	55	55	55	57
WEIGHT	kg	64		86		95	
IP PROTECTION OF DEVICE		IP21					

TYPE		GTV-E-68A	GTV-E-87A	GTV-E-107A
INPUT POWER(NCV)	kW	68,3/54	86,8/68,6	108,1/46,3
OUTPUT POWER (NCV)	kW	63,4/49,5	80,4/62,9	99,8/77,9
EFFICIENCY [3 POINT,MOD]	%	92,82/91,6	92,65/91,7	92,3/91,2
AIR FLOW	m ³ /h	7780	8450	11200
QUANTITY OF FAN	db	1	1	1
DIFFERENT OF AIR TEMPERATURE ΔT	°C	24,6	25	24,9
AIR THROW	m	33	35	37
EXHAUST PIPE / AIR SUPPLY DIAMETER	mm	Ø100/Ø150		
GAS CONNECTION		G3/4" ISO 228 OD		
ELECTRICAL CONNECTION		230V / 50Hz		
NOMINAL CURRENT CONSUMPTION	A	4,15	4,15	4,25
ELECTRICAL PERFORMANCE	kW	0,95	0,95	0,98
NOISE LEVEL	dB(A)	67	69	72
WEIGHT	kg	148	167	198
IP PROTECTION OF DEVICE		IP21		

TYPE		GTV-E-20C,CL	GTV-E-27C,CL	GTV-E-33C,CL	GTV-E-40C,CL	GTV-E-48C,CL	GTV-E-58C,CL
INPUT POWER (NCV)	kW	21,16,6	25,8/20,4	34,1/26,9	39,6/31,3	48,8/38,6	58,6/46,3
OUTPUT POWER (NCV)	kW	19,4/15,2	23,9/18,7	31,5/24,6	36,7/28,7	45,1/35,3	54,2/42,3
EFFICIENCY [3 POINT/MOD]	%	72,6/73,1	72,8/73,3	72,2/72,6	72,3/72,7	72,2/72,7	72,1/72,9
AIR FLOW	m ³ /h	2520	3110	3720	4490	5480	6410
QUANTITY OF FAN	pcs	1	1	1	1	1	1
DIFFERENT OF AIR TEMPERATURE ΔT [MAX/MIN]	°C	24,1	24,9	24,5	24,7	25,2	25
AIR THROW	m	12	16	18	20	22	25
EXHAUST PIPE / AIR SUPPLY DIAMETER	mm	Ø100/Ø100					
GAS CONNECTION		G1/2" ISO 228 OD					
ELECTRICAL CONNECTION		230V / 50Hz					
NOMINAL CURRENT CONSUMPTION (MAX/AVERAGE)	A	7,9/4,1	7,9/4,1	8,3/5	8,3/5	9,2/6	9,2/6
ELECTRICAL PERFORMANCE	W	943	943	1150	1150	1380	1380
NOISE LEVEL	dB(A)	56	58	56	58	58	58
WEIGHT	C kg	70		93		121	
IP PROTECTION OF DEVICE	CL kg	75		98		126	
		IP21					

ENCLOSURE 1 / B : GAS CONSUMPTION

TYPE	Input	Output	Gas consumption	
	3 POINT, MODULATION	3 POINT, MODULATION	3 POINT, MODULATION	3 POINT, MODULATION
	[kW]	[kW]	Natural gas [m ³ /h]	Propane [kg/h]
GTV-E-20	21,16,6	19,4/15,2	2,22/1,76	1,73/1,37
GTV-E-27	25,8/20,4	23,9/18,7	2,73/2,16	2,13/1,68
GTV-E-33	34,1/26,9	31,5/24,6	3,61/2,85	2,81/2,22
GTV-E-40	39,6/31,3	36,7/28,7	4,19/3,32	3,27/2,58
GTV-E-48	48,8/38,6	45,1/35,3	5,17/4,09	4,03/3,18
GTV-E-58	58,6/46,3	54,2/42,3	6,21/4,9	4,83/3,82
GTV-E-68	68,3/54	63,4/49,5	7,24/5,72	5,63/4,46
GTV-E-87	86,8/68,6	80,4/62,9	9,19/7,27	7,16/5,66
GTV-E-107	108,1/46,3	99,8/77,9	11,45/9,05	8,92/7,05

ENCLOSURE 2.: APPLIANCE DIMENSIONS PER TYPES

GTV-E-...A AXIAL FAN-TYPE 20...58 kW

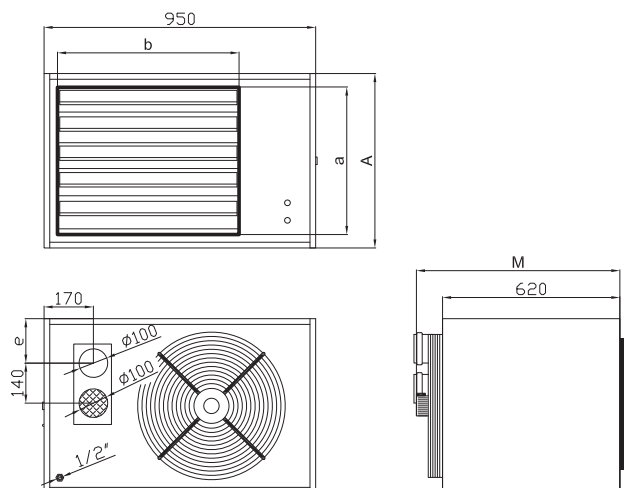

Type	A	a	b	M	e
GTV-E -20A	470	370	625	700	135
GTV-E -27A	470	370	625	700	135
GTV-E -33A	610	510	625	805	187
GTV-E-40A	610	510	625	805	187
GTV-E-48A	750	650	625	805	252
GTV-E-58A	750	650	625	805	252

GTV-...A AXIAL FAN-TYPE 68...107 kW

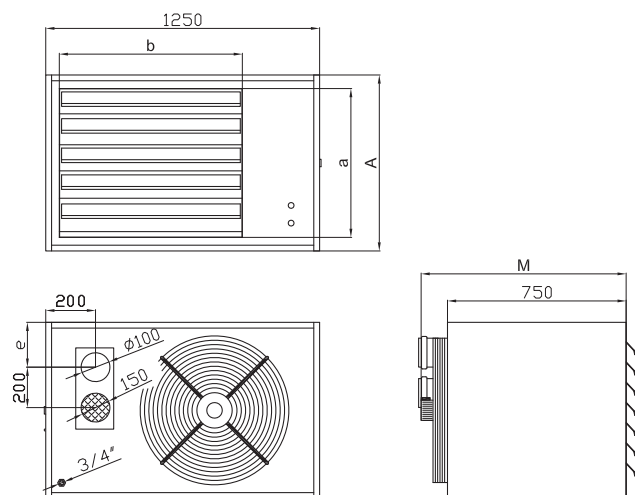

Type	A	a	b	M	e
GTV-E-68A	810	700	840	970	238
GTV-E-87A	960	850	840	970	318
GTV-E-107A	1110	1000	860	990	412

GTV-E-...C CENTRIFUGAL FAN-TYPE 20...58 kW

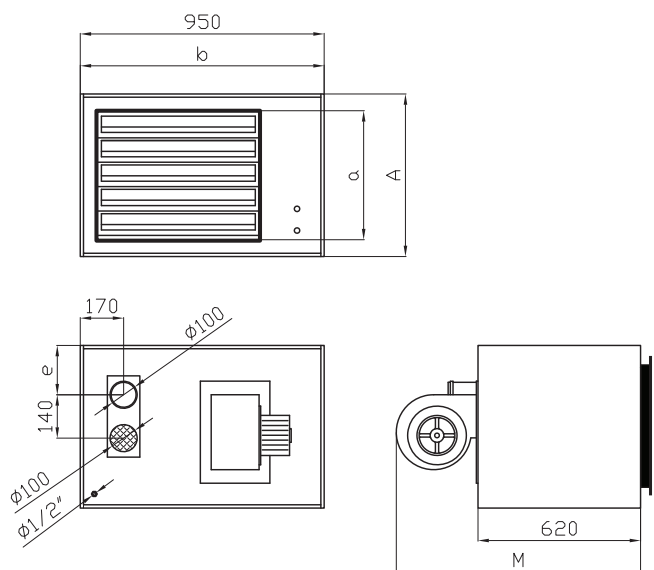

Type	A	a	b	M	e
GTV-E-20C	470	370	625	990	135
GTV-E-27C	470	370	625	990	135
GTV-E-33C	610	510	625	1040	187
GTV-E-40C	610	510	625	1040	187
GTV-E-48C	750	650	625	1110	252
GTV-E-58C	750	650	625	1110	252

GTV-E-...CL CENTRIFUGAL FAN-TYPE 20...58 kW

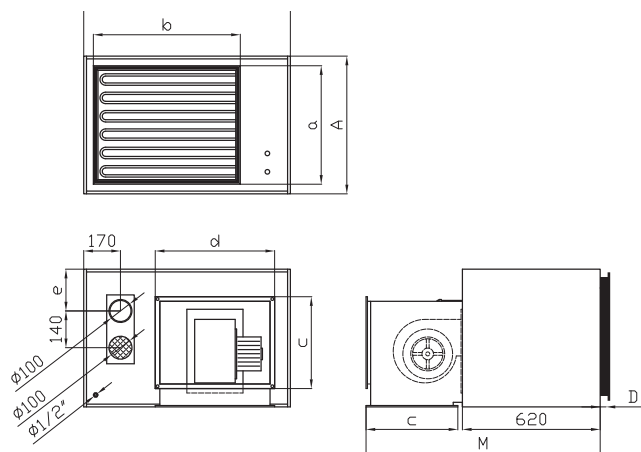

Type	A	a	b	c	d	M	D	e
GTV-E-20CL	470	350	600	350	500	1050	50	135
GTV-E-27CL	470	350	600	350	500	1050	50	135
GTV-E-33CL	610	500	600	400	550	1100	50	187
GTV-E-40CL	610	500	600	400	550	1100	50	187
GTV-E-48CL	750	650	600	450	600	1150	50	252
GTV-E-58CL	750	650	600	450	600	1150	50	252

! The dimensions of these new type GTV-E NOx reduced air heaters are same the dimensions of original GTV series

ENCLOSURE 3.: FLUE LONGS, ALLOWED PRESSURE DROPS

! ATTENTION! The joint of pipes must be sealed and fixed! Not allowed longer flue system as the above chart shows!

Supplement: The fresh air supply and venting set can contain an elbow 90°. In case of use more elbows, you need to reduce the length of fresh air supply and venting set, as follow:

- See the following:
- the pressure drop of 1m inox Ø100mm pipe is 2Pa
- elbow 90° is equal about 1m-length pipe (2-3Pa)

! It is allowed to use longer fresh air supply and venting set with isolation and condensate outlet. In this case, contact the manufacturer!

Type	GTV-E-20A, C, CL	GTV-E-27A, C, CL	GTV-E-33A, C, CL	GTV-E-40A, C, CL	GTV-E-48A, C, CL	GTV-E-58A, C, CL
Venting set type	Maximal length of venting set Ø 100 mm [m]					
B22	3	4	6	6	8	8
C12	3	4	6	6	8	8
C32	3	4	6	6	8	8
C52	3	4	6	6	8	8
Venting set type	Maximal pressure drop of venting set Ø 100 mm [Pa]					
B22	6	8	12	12	16	16
C12	6	8	12	12	16	16
C32	6	8	12	12	16	16
C52	6	8	12	12	16	16

Type	GTV-E-68A	GTV-E-87A	GTV-E-107A
Venting set type	Maximal length of venting set Ø 100 mm [m]		
B22	12	16	20
C12	12	16	20
C52	12	16	20
Venting set type	Maximal pressure drop of venting set Ø 100 mm [Pa]		
B22	24	32	40
C12	24	32	40
C52	24	32	40

ENCLOSURE 4.:TARGET COUNTRIES/GAS CATEGORIES

Exhaust type	Appliance category	Gas pressure of connection (mbar)	Gas categories	Target countries
B22, C12, C32, C52	I _{3p}	37	G31	BE, BG, HR, TR, CH, CZ, ES, FR, GR, IE, IT, LT, NL, PL, PT SI, SK
	I _{3p}	50	G31	AT, CH, DE, NL, SK, HU
	I _{2H}	20	G20	AT, BG, CH, CZ, DK, HR, EE, ES, FI, GR, IE, IT, LT, LV, NO, PT, RO, SE, SI, SK, TR
	I _{2H}	25	G20	HU
	I _{2E}	20	G20	DE, LU, PL, RO
	II _{2H3P}	20,37	G20,G31	AT, BG, CH, CZ, ES, GR,HR, IE, IT, PT, SI, SK, TR
	II _{2E3P}	20,37	G20,G31	PL
	II _{2H3P}	25,50	G20,G31	HU

The appliances were tested together with the flue system, recommended by the manufacturer.

The applied flue system parts: LIM-MONT ECO DIM, DW,
LIM-MONT ECO DIM DE.

Model: **GTV-E-20A / C / CL-3P 3-point controlled gas-fired forced convection air heater with axial fan**

B₁ Warm air heater: No

C₂ Warm air heater: No

C₄ Warm air heater: No

Type of fuel: Gas

Item	Symbol	Value	Unit	Item	Symbol	Value	Unit
Capacity				Useful efficiency			
Rated heating capacity	$P_{rated,h}$	19,4	kW	Useful efficiency at rated heating capacity	η_{nom}	83,45	%
Minimum capacity	P_{min}	15,2	kW	Useful efficiency at minimum capacity	η_{pl}	82,73	%
Electric power consumption				Other items			
At rated heating capacity	$e_{l,max}$	0,068	kW	Envelope loss factor	F_{env}	0,0	%
At minimal capacity	$e_{l,min}$	0,050	kW	Ignition burner power consumption	P_{ign}	0,0	kW
In standby mode	$e_{l,sb}$	0,0	kW	Emissions of nitrogen oxides	NOx	93	mg/kWh input energy (GCV)
Regulation (EU) 2016/2281				Emission efficiency	$\eta_{s,flow}$	93,28	%
				Seasonal space heating energy efficiency	$\eta_{s,h}$	72,7	%

Model: **GTV-E-20A / C / CL-MOD Modulated Indirect gas-fired forced convection air heater with axial fan**

B₁ Warm air heater: No

C₂ Warm air heater: No

C₄ Warm air heater: No

Type of fuel: Gas

Item	Symbol	Value	Unit	Item	Symbol	Value	Unit
Capacity				Useful efficiency			
Rated heating capacity	$P_{rated,h}$	19,4	kW	Useful efficiency at rated heating capacity	η_{nom}	83,45	%
Minimum capacity	P_{min}	15,2	kW	Useful efficiency at minimum capacity	η_{pl}	82,73	%
Electric power consumption				Other items			
At rated heating capacity	$e_{l,max}$	0,068	kW	Envelope loss factor	F_{env}	0,0	%
At minimal capacity	$e_{l,min}$	0,050	kW	Ignition burner power consumption	P_{ign}	0,0	kW
In standby mode	$e_{l,sb}$	0,0	kW	Emissions of nitrogen oxides	NOx	93	mg/kWh input energy (GCV)
Regulation (EU) 2016/2281				Emission efficiency	$\eta_{s,flow}$	93,28	%
				Seasonal space heating energy efficiency	$\eta_{s,h}$	73,1	%

Contact details

PAKOLE Trade Kft. H-8000, Székesfehérvár, Börgöndi út, 8-10

Model: **GTV-E-27A / C / CL-3P 3-point controlled gas-fired forced convection air heater with axial fan**

B₁ Warm air heater: No

C₂ Warm air heater: No

C₄ Warm air heater: No

Type of fuel: Gas

Item	Symbol	Value	Unit	Item	Symbol	Value	Unit
Capacity				Useful efficiency			
Rated heating capacity	$P_{rated,h}$	23,9	kW	Useful efficiency at rated heating capacity	η_{nom}	83,54	%
Minimum capacity	P_{min}	18,7	kW	Useful efficiency at minimum capacity	η_{pl}	82,82	%
Electric power consumption				Other items			
At rated heating capacity	$e_{l,max}$	0,068	kW	Envelope loss factor	F_{env}	0,0	%
At minimal capacity	$e_{l,min}$	0,050	kW	Ignition burner power consumption	P_{ign}	0,0	kW
In standby mode	$e_{l,sb}$	0,0	kW	Emissions of nitrogen oxides	NOx	97	mg/kWh input energy (GCV)
Regulation (EU) 2016/2281				Emission efficiency	$\eta_{s,flow}$	93,27	%
				Seasonal space heating energy efficiency	$\eta_{s,h}$	72,9	%

Model: **GTV-E-27A / C / CL-MOD Modulated Indirect gas-fired forced convection air heater with axial fan**

B₁ Warm air heater: No

C₂ Warm air heater: No

C₄ Warm air heater: No

Type of fuel: Gas

Item	Symbol	Value	Unit	Item	Symbol	Value	Unit
Capacity				Useful efficiency			
Rated heating capacity	$P_{rated,h}$	23,9	kW	Useful efficiency at rated heating capacity	η_{nom}	83,54	%
Minimum capacity	P_{min}	18,7	kW	Useful efficiency at minimum capacity	η_{pl}	82,82	%
Electric power consumption				Other items			
At rated heating capacity	$e_{l,max}$	0,068	kW	Envelope loss factor	F_{env}	0,0	%
At minimal capacity	$e_{l,min}$	0,050	kW	Ignition burner power consumption	P_{ign}	0,0	kW
In standby mode	$e_{l,sb}$	0,0	kW	Emissions of nitrogen oxides	NOx	97	mg/kWh input energy (GCV)
Regulation (EU) 2016/2281				Emission efficiency	$\eta_{s,flow}$	93,27	%
				Seasonal space heating energy efficiency	$\eta_{s,h}$	73,3	%

Contact details

PAKOLE Trade Kft. H-8000, Székesfehérvár, Börgöndi út, 8-10

Model: **GTV-E-33A / C / CL-3P 3-point controlled gas-fired forced convection air heater with axial fan**

B₁ Warm air heater: No

C₂ Warm air heater: No

C₄ Warm air heater: No

Type of fuel: Gas

Item	Symbol	Value	Unit	Item	Symbol	Value	Unit
Capacity				Useful efficiency			
Rated heating capacity	$P_{rated,h}$	31,5	kW	Useful efficiency at rated heating capacity	η_{nom}	83,36	%
Minimum capacity	P_{min}	24,7	kW	Useful efficiency at minimum capacity	η_{pl}	82,54	%
Electric power consumption				Other items			
At rated heating capacity	$e_{l,max}$	0,072	kW	Envelope loss factor	F_{env}	0,0	%
At minimal capacity	$e_{l,min}$	0,060	kW	Ignition burner power consumption	P_{ign}	0,0	kW
In standby mode	$e_{l,sb}$	0,0	kW	Emissions of nitrogen oxides	NOx	93	mg/kWh input energy (GCV)
Regulation (EU) 2016/2281				Emission efficiency	$\eta_{s,flow}$	92,79	%
				Seasonal space heating energy efficiency	$\eta_{s,h}$	72,3	%

Model: **GTV-E-33A / C / CL-MOD Modulated Indirect gas-fired forced convection air heater with axial fan**

B₁ Warm air heater: No

C₂ Warm air heater: No

C₄ Warm air heater: No

Type of fuel: Gas

Item	Symbol	Value	Unit	Item	Symbol	Value	Unit
Capacity				Useful efficiency			
Rated heating capacity	$P_{rated,h}$	31,5	kW	Useful efficiency at rated heating capacity	η_{nom}	83,36	%
Minimum capacity	P_{min}	24,7	kW	Useful efficiency at minimum capacity	η_{pl}	82,54	%
Electric power consumption				Other items			
At rated heating capacity	$e_{l,max}$	0,072	kW	Envelope loss factor	F_{env}	0,0	%
At minimal capacity	$e_{l,min}$	0,060	kW	Ignition burner power consumption	P_{ign}	0,0	kW
In standby mode	$e_{l,sb}$	0,0	kW	Emissions of nitrogen oxides	NOx	93	mg/kWh input energy (GCV)
Regulation (EU) 2016/2281				Emission efficiency	$\eta_{s,flow}$	92,79	%
				Seasonal space heating energy efficiency	$\eta_{s,h}$	72,8	%

Contact details

PAKOLE Trade Kft. H-8000, Székesfehérvár, Börgöndi út, 8-10

Model: **GTV-E-40A / C / CL-3P 3-point controlled gas-fired forced convection air heater with axial fan**

B₁ Warm air heater: No

C₂ Warm air heater: No

C₄ Warm air heater: No

Type of fuel: Gas

Item	Symbol	Value	Unit	Item	Symbol	Value	Unit
Capacity				Useful efficiency			
Rated heating capacity	$P_{rated,h}$	36,7	kW	Useful efficiency at rated heating capacity	η_{nom}	83,4	%
Minimum capacity	P_{min}	28,7	kW	Useful efficiency at minimum capacity	η_{pl}	82,5	%
Electric power consumption				Other items			
At rated heating capacity	$e_{l,max}$	0,072	kW	Envelope loss factor	F_{env}	0,0	%
At minimal capacity	$e_{l,min}$	0,060	kW	Ignition burner power consumption	P_{ign}	0,0	kW
In standby mode	$e_{l,sb}$	0,0	kW	Emissions of nitrogen oxides	NOx	97	mg/kWh input energy (GCV)
Regulation (EU) 2016/2281				Emission efficiency	$\eta_{s,flow}$	93,1	%
				Seasonal space heating energy efficiency	$\eta_{s,h}$	72,6	%

Model: **GTV-E-40A / C / CL-MOD Modulated Indirect gas-fired forced convection air heater with axial fan**

B₁ Warm air heater: No

C₂ Warm air heater: No

C₄ Warm air heater: No

Type of fuel: Gas

Item	Symbol	Value	Unit	Item	Symbol	Value	Unit
Capacity				Useful efficiency			
Rated heating capacity	$P_{rated,h}$	36,7	kW	Useful efficiency at rated heating capacity	η_{nom}	83,4	%
Minimum capacity	P_{min}	28,7	kW	Useful efficiency at minimum capacity	η_{pl}	82,5	%
Electric power consumption				Other items			
At rated heating capacity	$e_{l,max}$	0,072	kW	Envelope loss factor	F_{env}	0,0	%
At minimal capacity	$e_{l,min}$	0,060	kW	Ignition burner power consumption	P_{ign}	0,0	kW
In standby mode	$e_{l,sb}$	0,0	kW	Emissions of nitrogen oxides	NOx	97	mg/kWh input energy (GCV)
Regulation (EU) 2016/2281				Emission efficiency	$\eta_{s,flow}$	93,1	%
				Seasonal space heating energy efficiency	$\eta_{s,h}$	73,1	%

Contact details: PAKOLE Trade Kft. H-8000, Székesfehérvár, Börgöndi út, 8-10

Model: **GT-48A / C / CL-3P 3-point controlled gas-fired forced convection air heater with axial fan**

B₁ Warm air heater: No

C₂ Warm air heater: No

C₄ Warm air heater: No

Type of fuel: Gas

Item	Symbol	Value	Unit	Item	Symbol	Value	Unit
Capacity				Useful efficiency			
Rated heating capacity	$P_{rated,h}$	45,1	kW	Useful efficiency at rated heating capacity	η_{nom}	83,4	%
Minimum capacity	P_{min}	35,2	kW	Useful efficiency at minimum capacity	η_{pl}	82,4	%
Electric power consumption				Other items			
At rated heating capacity	$e_{l,max}$	0,095	kW	Envelope loss factor	F_{env}	0,0	%
At minimal capacity	$e_{l,min}$	0,074	kW	Ignition burner power consumption	P_{ign}	0,0	kW
In standby mode	$e_{l,sb}$	0,0	kW	Emissions of nitrogen oxides	NOx	93	mg/kWh input energy (GCV)
Regulation (EU) 2016/2281				Emission efficiency	$\eta_{s,flow}$	93,03	%
				Seasonal space heating energy efficiency	$\eta_{s,h}$	72,4	%

Model: **GTV-E-48A / C / CL-MOD Modulated Indirect gas-fired forced convection air heater with axial fan**

B₁ Warm air heater: No

C₂ Warm air heater: No

C₄ Warm air heater: No

Type of fuel: Gas

Item	Symbol	Value	Unit	Item	Symbol	Value	Unit
Capacity				Useful efficiency			
Rated heating capacity	$P_{rated,h}$	45,1	kW	Useful efficiency at rated heating capacity	η_{nom}	83,4	%
Minimum capacity	P_{min}	35,2	kW	Useful efficiency at minimum capacity	η_{pl}	82,4	%
Electric power consumption				Other items			
At rated heating capacity	$e_{l,max}$	0,095	kW	Envelope loss factor	F_{env}	0,0	%
At minimal capacity	$e_{l,min}$	0,074	kW	Ignition burner power consumption	P_{ign}	0,0	kW
In standby mode	$e_{l,sb}$	0,0	kW	Emissions of nitrogen oxides	NOx	93	mg/kWh input energy (GCV)
Regulation (EU) 2016/2281				Emission efficiency	$\eta_{s,flow}$	93,03	%
				Seasonal space heating energy efficiency	$\eta_{s,h}$	72,9	%

Contact details

PAKOLE Trade Kft. H-8000, Székesfehérvár, Börgöndi út, 8-10

Model: **GTV-E-58A / C / CL-3P 3-point controlled gas-fired forced convection air heater with axial fan**

B₁ Warm air heater: No

C₂ Warm air heater: No

C₄ Warm air heater: No

Type of fuel: Gas

Item	Symbol	Value	Unit	Item	Symbol	Value	Unit
Capacity				Useful efficiency			
Rated heating capacity	$P_{rated,h}$	54,2	kW	Useful efficiency at rated heating capacity	η_{nom}	83,4	%
Minimum capacity	P_{min}	42,3	kW	Useful efficiency at minimum capacity	η_{pl}	82,3	%
Electric power consumption				Other items			
At rated heating capacity	$e_{l,max}$	0,095	kW	Envelope loss factor	F_{env}	0,0	%
At minimal capacity	$e_{l,min}$	0,074	kW	Ignition burner power consumption	P_{ign}	0,0	kW
In standby mode	$e_{l,sb}$	0,0	kW	Emissions of nitrogen oxides	NOx	97	mg/kWh input energy (GCV)
Regulation (EU) 2016/2281				Emission efficiency	$\eta_{s,flow}$	92,91	%
				Seasonal space heating energy efficiency	$\eta_{s,h}$	72,3	%

Model: **GTV-E-58A / C / CL-MOD Modulated Indirect gas-fired forced convection air heater with axial fan**

B₁ Warm air heater: No

C₂ Warm air heater: No

C₄ Warm air heater: No

Type of fuel: Gas

Item	Symbol	Value	Unit	Item	Symbol	Value	Unit
Capacity				Useful efficiency			
Rated heating capacity	$P_{rated,h}$	54,2	kW	Useful efficiency at rated heating capacity	η_{nom}	83,4	%
Minimum capacity	P_{min}	42,3	kW	Useful efficiency at minimum capacity	η_{pl}	82,3	%
Electric power consumption				Other items			
At rated heating capacity	$e_{l,max}$	0,095	kW	Envelope loss factor	F_{env}	0,0	%
At minimal capacity	$e_{l,min}$	0,074	kW	Ignition burner power consumption	P_{ign}	0,0	kW
In standby mode	$e_{l,sb}$	0,0	kW	Emissions of nitrogen oxides	NOx	97	mg/kWh input energy (GCV)
Regulation (EU) 2016/2281				Emission efficiency	$\eta_{s,flow}$	92,91	%
				Seasonal space heating energy efficiency	$\eta_{s,h}$	72,8	%

Contact details

PAKOLE Trade Kft. H-8000, Székesfehérvár, Börgöndi út, 8-10

Model: **GTV-E-68A-3P 3-point controlled gas-fired forced convection air heater with axial fan**

B₁ Warm air heater: No

C₂ Warm air heater: No

C₄ Warm air heater: No

Type of fuel: Gas

Item	Symbol	Value	Unit	Item	Symbol	Value	Unit
Capacity				Useful efficiency			
Rated heating capacity	$P_{rated,h}$	63,4	kW	Useful efficiency at rated heating capacity	η_{nom}	83,6	%
Minimum capacity	P_{min}	49,4	kW	Useful efficiency at minimum capacity	η_{pl}	82,5	%
Electric power consumption				Other items			
At rated heating capacity	el_{max}	0,095	kW	Envelope loss factor	F_{env}	0,0	%
At minimal capacity	el_{min}	0,074	kW	Ignition burner power consumption	P_{ign}	0,0	kW
In standby mode	el_{sb}	0,0	kW	Emissions of nitrogen oxides	NOx	93	mg/kWh input energy (GCV)
Regulation (EU) 2016/2281				Emission efficiency	$\eta_{s,flow}$	93,24	%
				Seasonal space heating energy efficiency	$\eta_{s,h}$	72,9	%

Model: **GTV-E-68A -MOD Modulated Indirect gas-fired forced convection air heater with axial fan**

B₁ Warm air heater: No

C₂ Warm air heater: No

C₄ Warm air heater: No

Type of fuel: Gas

Item	Symbol	Value	Unit	Item	Symbol	Value	Unit
Capacity				Useful efficiency			
Rated heating capacity	$P_{rated,h}$	63,4	kW	Useful efficiency at rated heating capacity	η_{nom}	83,6	%
Minimum capacity	P_{min}	49,4	kW	Useful efficiency at minimum capacity	η_{pl}	82,5	%
Electric power consumption				Other items			
At rated heating capacity	el_{max}	0,095	kW	Envelope loss factor	F_{env}	0,0	%
At minimal capacity	el_{min}	0,074	kW	Ignition burner power consumption	P_{ign}	0,0	kW
In standby mode	el_{sb}	0,0	kW	Emissions of nitrogen oxides	NOx	93	mg/kWh input energy (GCV)
Regulation (EU) 2016/2281				Emission efficiency	$\eta_{s,flow}$	93,24	%
				Seasonal space heating energy efficiency	$\eta_{s,h}$	73,4	%

Contact details

PAKOLE Trade Kft. H-8000, Székesfehérvár, Börgöndi út, 8-10

Model: **GTV-E-87A-3P 3-point controlled gas-fired forced convection air heater with axial fan**

B₁ Warm air heater: No

C₂ Warm air heater: No

C₄ Warm air heater: No

Type of fuel: Gas

Item	Symbol	Value	Unit	Item	Symbol	Value	Unit
Capacity				Useful efficiency			
Rated heating capacity	$P_{rated,h}$	80,4	kW	Useful efficiency at rated heating capacity	η_{nom}	83,5	%
Minimum capacity	P_{min}	62,9	kW	Useful efficiency at minimum capacity	η_{pl}	82,6	%
Electric power consumption				Other items			
At rated heating capacity	$e_{l,max}$	0,095	kW	Envelope loss factor	F_{env}	0,0	%
At minimal capacity	$e_{l,min}$	0,074	kW	Ignition burner power consumption	P_{ign}	0,0	kW
In standby mode	$e_{l,sb}$	0,0	kW	Emissions of nitrogen oxides	NOx	97	mg/kWh input energy (GCV)
Regulation (EU) 2016/2281				Emission efficiency	$\eta_{s,flow}$	92,13	%
				Seasonal space heating energy efficiency	$\eta_{s,h}$	72,1	%

Model: **GTV-E-87A - MOD Modulated Indirect gas-fired forced convection air heater with axial fan**

B₁ Warm air heater: No

C₂ Warm air heater: No

C₄ Warm air heater: No

Type of fuel: Gas

Item	Symbol	Value	Unit	Item	Symbol	Value	Unit
Capacity				Useful efficiency			
Rated heating capacity	$P_{rated,h}$	80,4	kW	Useful efficiency at rated heating capacity	η_{nom}	83,5	%
Minimum capacity	P_{min}	62,9	kW	Useful efficiency at minimum capacity	η_{pl}	82,6	%
Electric power consumption				Other items			
At rated heating capacity	$e_{l,max}$	0,095	kW	Envelope loss factor	F_{env}	0,0	%
At minimal capacity	$e_{l,min}$	0,074	kW	Ignition burner power consumption	P_{ign}	0,0	kW
In standby mode	$e_{l,sb}$	0,0	kW	Emissions of nitrogen oxides	NOx	97	mg/kWh input energy (GCV)
Regulation (EU) 2016/2281				Emission efficiency	$\eta_{s,flow}$	92,13	%
				Seasonal space heating energy efficiency	$\eta_{s,h}$	72,6	%

Contact details

PAKOLE Trade Kft. H-8000, Székesfehérvár, Börgöndi út, 8-10

Model: **GTV-E-107A-3P 3-point controlled gas-fired forced convection air heater with axial fan**

B₁ Warm air heater: No

C₂ Warm air heater: No

C₄ Warm air heater: No

Type of fuel: Gas

Item	Symbol	Value	Unit	Item	Symbol	Value	Unit
Capacity				Useful efficiency			
Rated heating capacity	$P_{rated,h}$	99,8	kW	Useful efficiency at rated heating capacity	η_{nom}	83,2	%
Minimum capacity	P_{min}	77,9	kW	Useful efficiency at minimum capacity	η_{pl}	82,2	%
Electric power consumption				Other items			
At rated heating capacity	$e_{l,max}$	0,095	kW	Envelope loss factor	F_{env}	0,0	%
At minimal capacity	$e_{l,min}$	0,074	kW	Ignition burner power consumption	P_{ign}	0,0	kW
In standby mode	$e_{l,sb}$	0,0	kW	Emissions of nitrogen oxides	NOx	93	mg/kWh input energy (GCV)
Regulation (EU) 2016/2281				Emission efficiency	$\eta_{s,flow}$	92,68	%
				Seasonal space heating energy efficiency	$\eta_{s,h}$	72,2	%

Model: **GTV-E-107A -MOD Modulated Indirect gas-fired forced convection air heater with axial fan**

B₁ Warm air heater: No

C₂ Warm air heater: No

C₄ Warm air heater: No

Type of fuel: Gas

Item	Symbol	Value	Unit	Item	Symbol	Value	Unit
Capacity				Useful efficiency			
Rated heating capacity	$P_{rated,h}$	99,8	kW	Useful efficiency at rated heating capacity	η_{nom}	83,2	%
Minimum capacity	P_{min}	77,9	kW	Useful efficiency at minimum capacity	η_{pl}	82,2	%
Electric power consumption				Other items			
At rated heating capacity	$e_{l,max}$	0,095	kW	Envelope loss factor	F_{env}	0,0	%
At minimal capacity	$e_{l,min}$	0,074	kW	Ignition burner power consumption	P_{ign}	0,0	kW
In standby mode	$e_{l,sb}$	0,0	kW	Emissions of nitrogen oxides	NOx	93	mg/kWh input energy (GCV)
Regulation (EU) 2016/2281				Emission efficiency	$\eta_{s,flow}$	92,68	%
				Seasonal space heating energy efficiency	$\eta_{s,h}$	72,7	%

Contact details

PAKOLE Trade Kft. H-8000, Székesfehérvár, Börgöndi út, 8-10

GUARANTEE AND SERVICES

PRESERVE THIS WARRANTY

Type: _____

Serial no.: _____

Date of purchasing: _____

LIMITED GUARANTEE *

The manufacturer guarantee the customer that the product and its parts are free from material and production failures. During normal use the warranty is 2 years. This warranty concerns the first retail customer.

The guarantee concerns the costs of laboratory investigations and the parts, which are needed for proper operation. The delivery and unforeseeable costs belong also to the mending costs and do not contain compensation costs.

Guarantee mending can only be realized by authorized retailer or service centre.

The guarantee does not concern the following failures, which are caused by: improper using, damaging, neglect, accident, lack of maintenance, normal attrition, transformation, modification and operation influenceable factor, contaminated fuel, installation of non-suitable part and mending which is done by not authorized retailer or service station.

The regular maintenance is the owner's responsibility.

The manufacturer does not assume the responsibility in case of accidentally happened or directly caused mistake respectively improper using.

***We reserve the right to change of this specification without extra notification. The guarantee can be applied in accordance with above defined.
Additional guarantee is not accepted.**

Guarantee servicing

If your appliance needs guarantee service in that case it can be requested at nearest authorized service station giving in the appliance for repairs.

Mending services

Take the appliance to the nearest authorized service station. If the device is not under guarantee the service cost will be invoiced to the customer at defined price. The service centres are independent from one another and may have different owners. We reserve the right to change of this specification without extra notification. If you would like to contact us the type and serial number of device

always be at hand. In case of other needed information write to the following address:

PAKOLE TRADE Kft.

H-8000 Székesfehérvár, Börgöndi út 8-10.

Tel.: +36 22 316 484

Fax.: +36 22 316 074



PAKOLE

www.pakole.com

PAKOLE TRADE LLC.

H-8000 Székesfehérvár, Börgöndi út 8-10.

<http://www.pakole.com>

E-mail: mail@pakole.hu

Tel.: +36 22 316 484